



MICROWELL



Installation and user manual

POOL DEHUMIDIFIER

Model: DRY 300 WAVE
DRY 400 WAVE
DRY 500 WAVE



Version: 01/2024





Thank you, for purchasing a Microwell swimming pool dehumidifier. You have probably chosen the best and most energy efficient dehumidifier for your pool. Before you use this device, it is necessary to carefully read the entire Installation and user manual. It is not allowed to commence the heat pump installation or operation unless full content of this Installation and user manual is understood and acknowledged. Please keep the Installation and user manual available in the case of any future reference is required. Please provide this information to each user of the device. Please mind

local regulations in your country regarding installation and usage of this heat pump which are valid in addition to this User manual.

CONTENT

1. WASTE DISPOSAL INFORMATION.....	3
2. SAFETY MEASURES.....	3
2.1 ELECTRICAL SAFETY	3
2.2 USAGE PRECAUTIONS	4
2.3 HANDLING PRECAUTIONS	5
3. PRODUCT DESCRIPTION	6
3.1 DESCRIPTION OF BASIC PARTS.....	9
3.2 FRESH AIR SUPPLY (ON REQUEST AS ACCESSORY)	10
4. HANDLING INSTRUCTIONS	11
4.1 HUMIDISTAT.....	11
4.2 HUMIDITY CONTROL BY REMOTE CONTROLLER - ON REQUEST.....	11
4.3 HUMIDITY CONTROL BY EXTERNAL WIRED HUMIDISTAT EBERLE	13
4.4 FAN REGULATION.....	14
4.5 COMPRESSOR CONTROL	15
5. INSTALLATION MANUAL	15
5.1 DEVICE LOCATION.....	16
5.2 DEVICE FIXATION	18
5.3 CONDENSATION WATER DRAINAGE	23
5.4 MAIN POWER SUPPLY CONNECTION.....	25
5.5 LPHW HOT WATER HEATING ELEMENT FOR ADDITIONAL HEATING – ON REQUEST	32
.....	34
5.6 ELECTRIC HEATING	35
5.7 DEFROSTING BY 4-WAY VALVE (DRY 300/500)– ON REQUEST	36
5.8 AIR FILTER – ON REQUEST.....	36
5.9 THROUGH THE WALL INSTALLATION (TTW) – ON REQUEST ONLY	38
6 TECHNICAL DATA	53
6.1 TECHNICAL DATA CHART*	53
7 SUMMER SHUT DOWN	68
7.1 TROUBLESHOOTING – SAVE TIME AND MONEY	68
7.2 MAINTENANCE INSTRUCTIONS.....	69

7.3	CLEANING BY SUPERCHLORING	69
7.4	OPERATION DURING CONSTRUCTION	69
7.5	MICROLIGHT+	69
8	WARRANTY CONDITIONS.....	71

1. WASTE DISPOSAL INFORMATION

When using this dehumidifier in European countries, the following must be respected:

DISPOSAL: Do not dispose this product as unsorted municipal waste. It is prohibited to dispose this dehumidifier in domestic / household waste. It is prohibited to dispose this appliance into forests or natural landscape. This could lead into local soil pollution. Collection of such waste must be treated individually.



DISPOSAL POSSIBILITIES:

1. The municipality has established a collection system where electronic waste can be disposed.
2. When buying a new product, the retailer or the manufacturer may take back the old appliance free of charge.
3. Old appliance may contain valuable resources which could be sold to scrap material dealers.
4. Packaging materials such as carton box or plastic / bubble foil can be recycled. Please use your local waste separation services.



2. SAFETY MEASURES

These devices are primarily designed for indoor swimming pools, smaller swimming pools, spas, saunas and alternatively for laundry rooms, dryers and other locations. See the technical data chart to check model suitability to swimming pool area.

For correct and optimal operation of this device, it is necessary to keep the air temperature in the pool hall approximately 2 - 3 ° C higher than the pool water temperature.. It is also necessary to maintain the air temperature in the pool hall in between the operating temperature range of the dehumidifier (specified in the Technical Data section), based on specific selection of the operating temperature of accessories selected for the device. Lower air temperatures outside the operating temperature range can damage the device due to freezing. Higher temperatures outside the operating temperature range may damage the unit due to unit overheating.

It is necessary to follow instructions in this Installation and user manual and local regulations in your country that regulate the installation and usage of this device. Incorrect, improper use or operation contradictory to this Installation and user manual may lead to an injury or property damage and will lead to loss of warranty. To prevent injury or property damage the following instructions must be followed:

2.1 Electrical safety



- The device operates at dangerous electrical current.
- Only authorized persons with particular electro-technical qualification can manipulate with unit.
- Danger of electrical shock.
- Do not exceed the required power supply.

- Do not turn a device that shows signs of possible damage such as broken packaging, broken or otherwise damaged unit's chassis or cover, smoke, smell, damaged power cord etc. on.
- **It is necessary to use appropriate Residual current circuit breaker (RCD) for connection of the dehumidifier to main power supply.**
- Do not manipulate device with wet hands.
- Do not clean device with water.
- Before cleaning the device, unplug the power cord and switch off the circuit breaker of the unit's power supply.
- Installation, service or repair must be performed by a qualified technician.
- When the device is not intended to be used for a longer time, we recommend switching the circuit breaker of the unit's power supply off.
- Unit must be installed in vertical position to avoid condensate water to enter electrical part of the unit.
- It is forbidden to install the unit close to devices that may cause electrical or frequency disturbance such as welding machines, motors or rotors, WIFI/WLAN routers or repeaters.
- It is forbidden to alter electrical installation of the device. It is also forbidden to alter any other part or functionality of the device.

2.2 Usage precautions



- Do not cover or block the intake or exhaust openings. It is forbidden to block or cover the intake or exhaust openings with clothes, towels, buckets, canoes, ceiling beams, etc.
- **Do not install or place any heating appliances close to intake grilles / louvers. It could continually overheat the dehumidifier and result in its malfunction or damage.**
- Do not climb or sit on the unit.
- Do not place any objects on the top of the unit (e.g. boxes, flower vases, etc.)
- Never push or push any objects into any hose or hole.
- Do not spray any flammable substances on the device, as this may cause a fire.
- Do not clean the device with aggressive cleaning agents, which may damage or deform the unit.
- Use the device only for the purpose for which it was manufactured, as described in the instruction manual. Do not use parts that are not recommended.
- Do not drink or otherwise use condensate that has been aspirated by the unit. Do not return water to the pool. Water can be contaminated with bacteria.
- Children are not allowed to operate, touch or play with the unit.
- **Children are not allowed to handle the packaging, plastic / bubble foil. Risk of suffocation!**
- **Prevent children from being injured or injured by handling the unit, its parts, or its packaging. Small parts, such as the screws can be swallowed by children and cause injury.**
- Do not leave the children in the swimming pool hall unattended.

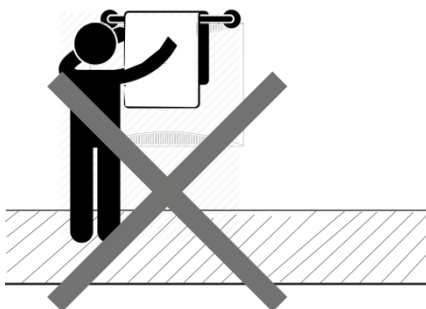

- Do not dry wet towels or swimsuits on the unit and do not put other objects on top of it (e.g. boxes, vases with flowers, etc.).

2.3 Handling precautions

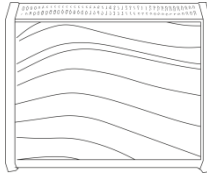
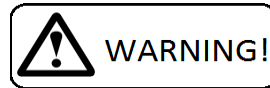

Keep in vertical position for 2 hours



Leave the unit in a vertical upright position for at least 2 hours before mounting. It is necessary to stabilize the refrigerant charge and especially to return the oil to the compressor tray. Oil could get out of the tray during transport and handling, and this could adversely affect the function of the dehumidifier.

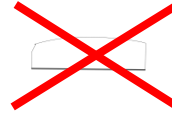

- Transport in a horizontal position or overturning the unit may damage the compressor, which may result in malfunction or damage to the unit and will void the warranty.
- The device must be handled carefully and with special care to avoid mechanical damage.

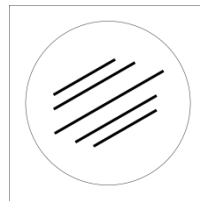
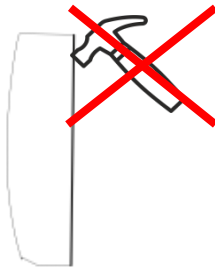

Beware of scratches. Handle the device carefully. Avoid contact with surfaces that may scratch the device.

- It is forbidden to exert any unsuitable mechanical force on the unit, which may cause mechanical damage to the device (e.g. place a drill, vacuum cleaner, etc. on the device)

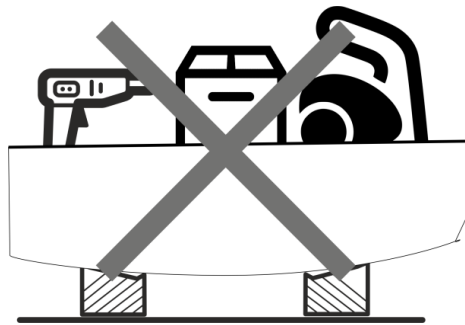

- It is forbidden to freely drop the device on the ground or any hard or rough surface that can lead to a hard impact of the device and scratch the cover. As the owner of the area make sure that your installer does not damage the cover or a part of the device during handling and installation.

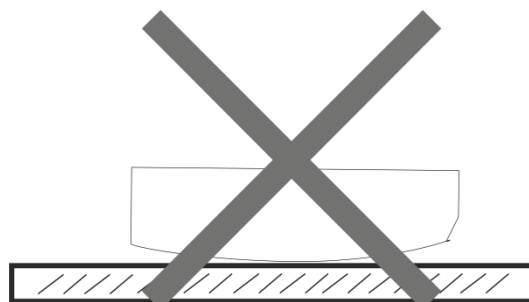
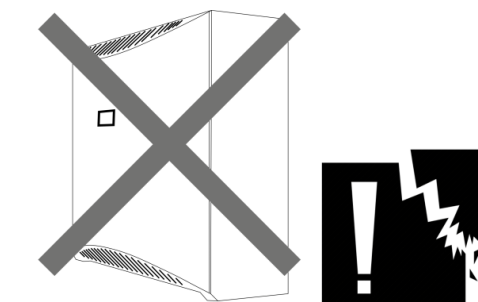

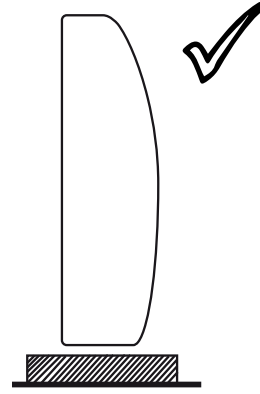
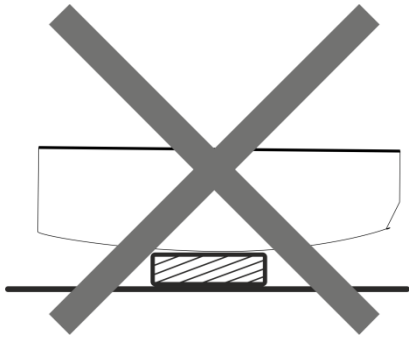



- Please notify your reseller or distributor if the delivered unit had been damaged. The unit may appear to work fine at first, but minor damage may cause the unit to stop working properly in a short time. In this case the unit must be inspected and its further use must be approved by the seller.
- Please notify your reseller or distributor if you notice immediately after installation that the unit is not working properly.
- In case of device failure resulting from improper handling or mechanical damage (impact, hit, fall, etc.), the manufacturer reserves the right to evaluate the continuity of warranty.

3. PRODUCT DESCRIPTION





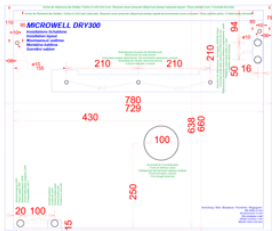



The unit was delivered in a carton box on a wooden pallet. Please unpack the unit and check the content. **It should include the following:**



Package:

Name/ code	Picture	Name/ code	Picture
1 -Dehumidifier 1x		2 – wall console 1x	
3 – Condensate drain hose (illustration photo) 1x		4 - Installation and user manual (illustration photo) 1x	







<p>5 – Installation template 1x</p>		<p>6 – Fixing screws for a cross screwdriver D6 and dowels D10 (illustration photo) 4x</p>	
--	---	--	---

Additional accessories (on request):

Name/ code	Picture	Name/ code	Picture
<p>1 – External wireless humidistat and thermostat DRY EASY 300 1x</p> <p>Part of the package (white box), is located under the main cover at the fan (Dry300 / 400) or above the capillary on the right side (Dry500)</p> <div style="display: flex; justify-content: space-around; margin-top: 20px;"> <div data-bbox="225 1176 456 1234" style="border: 1px solid black; padding: 2px;">Easy300 / Eberle</div> <div data-bbox="523 862 726 1115" style="text-align: center;"> <p>Dry 300</p>   </div> </div> <div style="display: flex; justify-content: space-around; margin-top: 20px;"> <div data-bbox="236 1339 445 1384" style="border: 1px solid black; padding: 2px;">Solenoid valve</div> <div data-bbox="523 1137 719 1429" style="text-align: center;"> <p>Dry 500</p>  </div> </div>		<p>2 – External wired humidistat EBERLE</p> <p>Separate small box glued to the device (cardboard box) see picture 1</p>	
<p>3 - Solenoid valve - valve and coil 1x</p> <p>Part of the package (white box) is located under the main cover at the fan (Dry300 / 400) or above the capillary on the right side (Dry500) see picture 1</p>		<p>4 – Mobie stand 1x</p> <p>Packaged separately</p>	
<p>5 – air filter Installed inside the device</p> <p>An alternative is an air filter in the wall mounting grille</p>		<p>6 – fresh air supply More information found in section 3.2 Fresh air supply</p>	

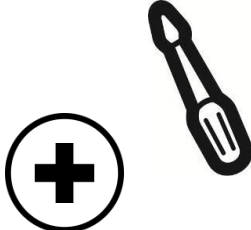
<p>7 – wall mounting kit – 2x elbow fitting, 2x straight piece, 2x grid Packaged in separate box</p>		<p>8 – Power cord 230V 2m Part of the package (the cord is twisted on the units back)</p>	
<p>9 –Fixed stand 1x Packaged separately</p>			

List of necessary tools (is not part of packaging):

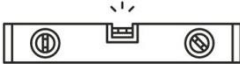
Name/ code	Picture	Name/ code	Picture
<p>1 - Drill 1x</p>		<p>3 – Drill bit 10mm 1x</p>	
<p>2 – Screwdriver Phillips PH2 1x</p>		<p>Vacuum cleaner and ladder</p>	
<p>5 – Small hammer 1x</p>		<p>6 - Meter 1x</p>	
<p>7- Spirit level 1x</p>			

3.1 Description of basic parts

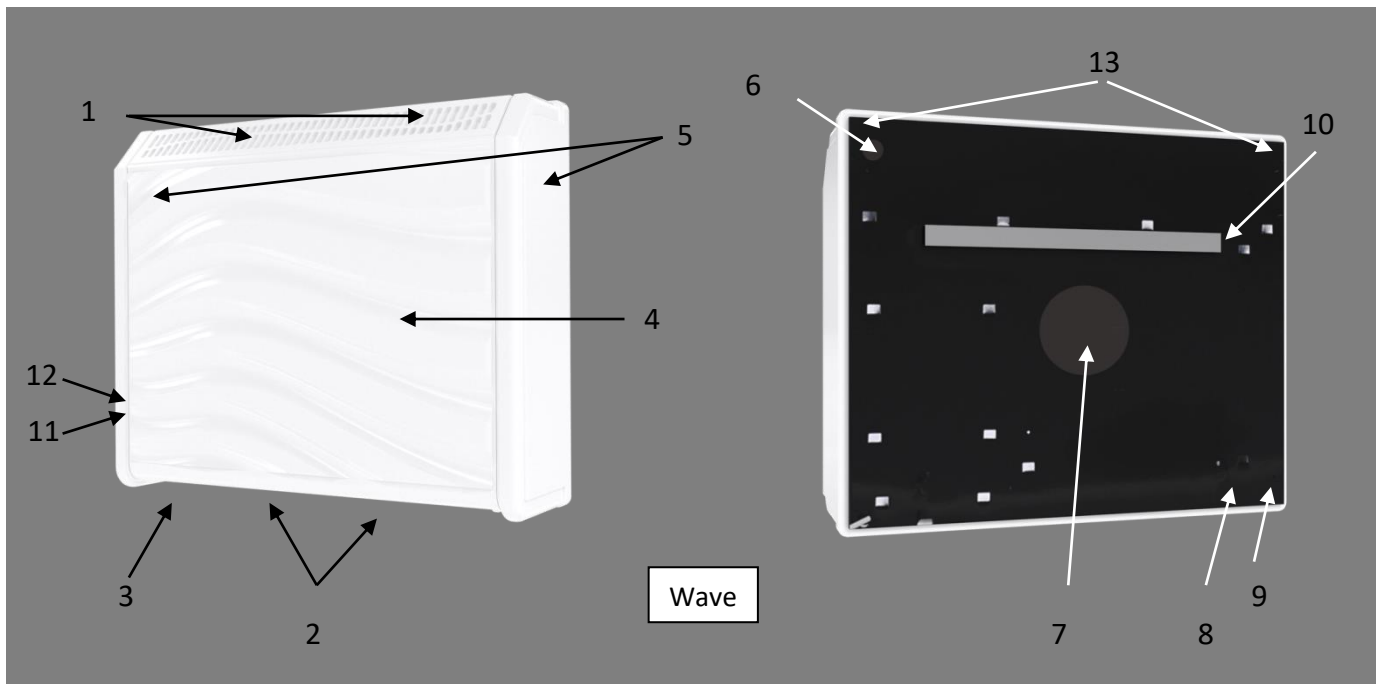

Legenda:

- 1 – Air exhaust
- 2 – Air suction
- 3 – Mechanical humidistat (on the bottom)
- 4 – Acrylic cover
- 5 – Possible heating water supply from the right / left side ½ “(on request as accessory)
- 6 – Possible heating water supply from the back ½ “(on request as accessory)
- 7 – Fresh air supply Ø 100 mm (on request as accessory)
- 8 – Condensate drain Ø outer 20 mm (Ø inner 16 mm)
- 9 – Power supply 230 V
- 10 – Wall-mounting console
- 11 – Position (under the cover) of the connection box for the main power supply
- 12 – position (under cover) of fan mode switch
- 13 – position of fixing screws

Premium Through The Wall

DRY300/400 DUCT

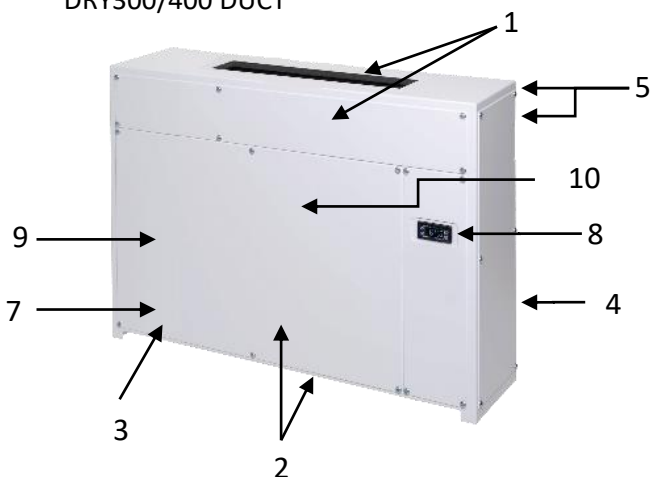

Legend:

- 1 – Air exhaust / AIR OUT/ = supply for pool hall
- 2 – Air suction /AIR IN/ = exhaust from pool hall
- 3 – Mechanical humidistat (on the bottom)
- 4 – Metal cover
- 5 – LPHW connection B-BACK or R-RIGHT
- 6 – Condensate drain Ø 16 mm (from the back)
- 7 – Main power supply connection box 230V (under the main cover)
- 8 – Built in digital controller
- 9 – Compressor (under the cover)
- 10 – Fan(s) / Ventilator (s)

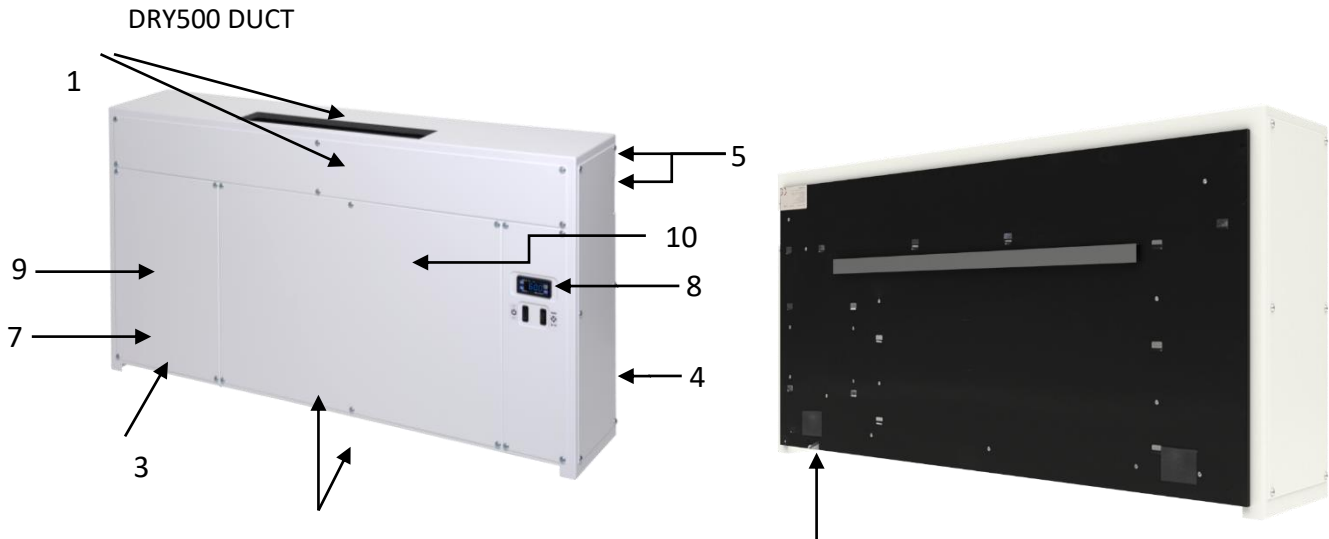

Standard Through The Wall



Due to simplicity, this User's Manual does not include all visualisations for all three basic makes of the dehumidifier line "Wave". Please refer to all visualisations, drawings and sketches as illustratory.

3.2 Fresh air supply (on request as accessory)

Each MICROWELL DRY dehumidifier has the option of fresh air supply. The air supply is located below the condenser, which effectively heats the incoming fresh air due to heat recovery.

The metal fresh air connection is supplied already mounted on the dehumidifier, but towards the inside. When installing the dehumidifier, it is necessary to remove the flange to wind it correctly (opposite to the one supplied). For example, a plastic pipe is then mounted on the flange, which conducts the air through the wall.

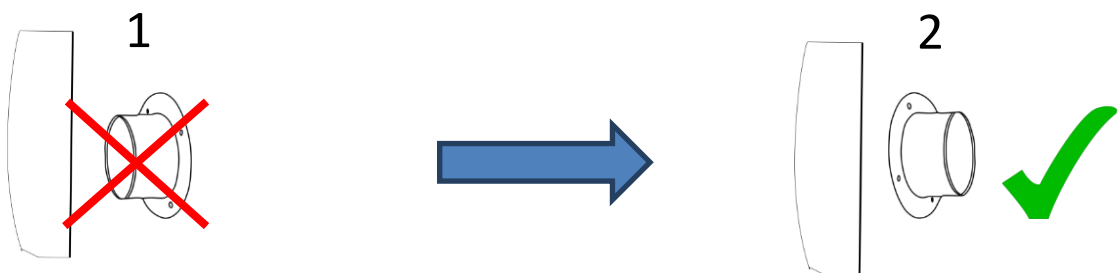

4. HANDLING INSTRUCTIONS

4.1 Humidistat

Your dehumidifier is equipped with a built-in mechanical humidistat as standard. On request, it can be equipped with an external wired humidistat, or an external wireless humidistat and thermostat. A detailed description of the operation of these controllers is described in separate manuals, which are part of their own packaging.

Picture:
Mechanical
humidistat
indicator wheel.



The built-in mechanical humidistat is located in the lower left part of the device (under the cover of the dehumidifier). The humidistat checks the humidity level of the sucked-in air and, depending on the set value, starts or dehumidifies. Ideal humidity of a pool hall is 55-65%. We recommend setting the humidistat to 60%.

Humidistat setting ("V").
Currently, the humidistat in the
photo is set to 70%.



Humidity scale. DRY = continuous
dehumidification, STOP = stop
dehumidification. Values of 20-30-40-
50-60-70 correspond to relative
humidity.

The mechanical humidistat is a reliable way of measuring and subsequently regulating the humidity in your pool hall. Its advantage is its high reliability as it measures moisture based on the physical properties of the measuring fiber. In the case of a mechanical humidistat, a hysteresis of 4% and a maximum of 8% must be taken into account. Hysteresis is a property where the off or on is shifted to a higher or lower relative humidity value than the actual desired one.

If you use an external (wired or wireless) humidistat, a mechanical humidistat also remains installed in the device. It functions as a backup in case of failure of the external humidistat. In this case, the mechanical humidistat is set to 70%. We recommend the user not to change this setting.



The manufacturer recommends setting the required humidity value between the range of 55 to 65% RH. Reducing humidity below this range is not desirable for physiological as well as building protection reasons. In addition, it increases electricity consumption. Settings above 65% RH can create an environment where the humidity reaches a critical level of 70%, which could lead to an overgrowth of unwanted bacteria and the formation of mold, or damage to home textiles.

4.2 Humidity control by remote controller - on request

An external wireless humidistat and the DRY EASY 300 thermostat can be ordered for the pool dehumidifier which is equipped with a built-in mechanical humidistat as standard.

Wireless communication takes place in the 868 MHz band, where the emphasis is on the reliability and range of the controller. The dehumidifier is controlled primarily by a remote humidistat,

provided that the built-in humidity controller in the dehumidifier is set to a higher desired humidity value than the remote humidistat.



1. TRANSMITTER



2. RECEIVER



3. ANTENNA



The manufacturer recommends setting the required humidity value on the DRY EASY 300 in the range of 55 to 65% RH.

If the built-in humidistat has been set to a lower value than the remote humidistat, the built-in humidistat will take over the humidity control in the room, in which case the dehumidifier will not respond to signals from the remote humidistat. Therefore, it is recommended to set the built-in humidistat to 70% RH or more.

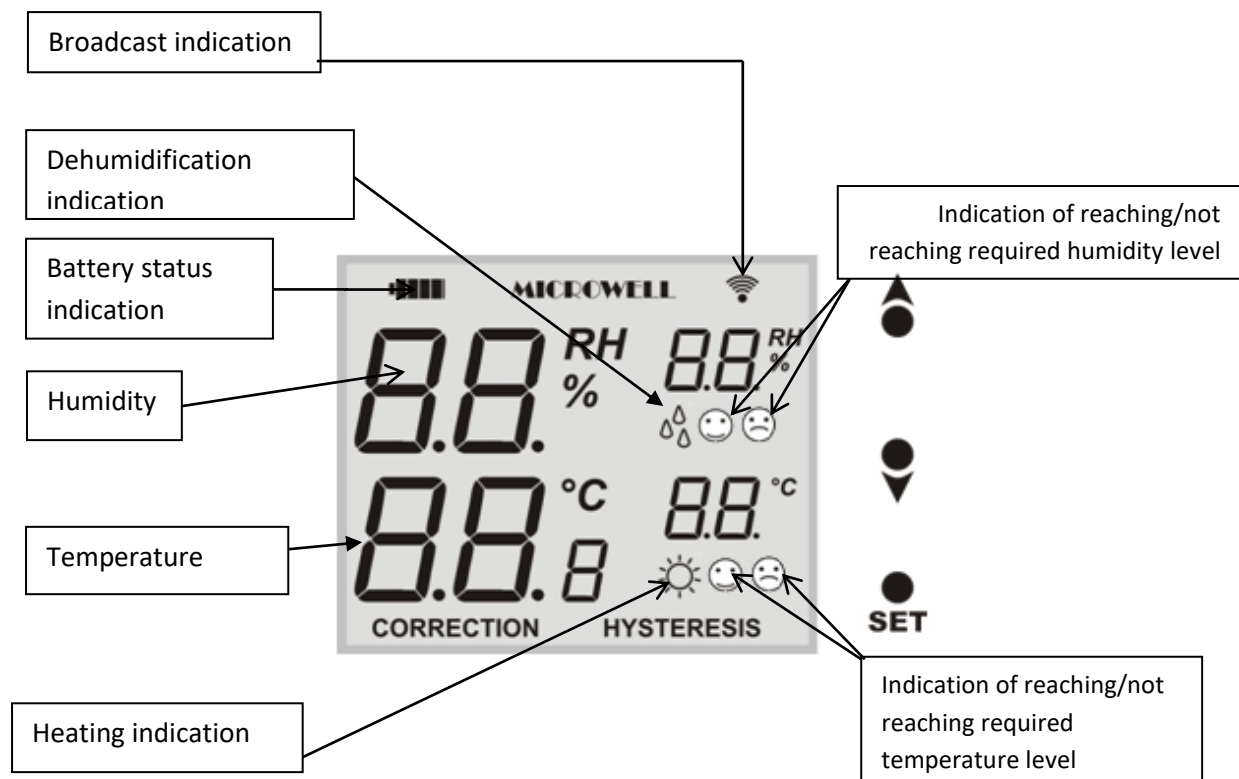

Additional functions and operation of the remote humidistat are described in the separate enclosed instructions.

Location of receiver and antenna

A: The receiver is located inside the electrobox and the antenna is located on the outside of it.

B: For TTW version / through the wall / we recommend pulling the antenna into the pipe in the wall. Follow the picture below.

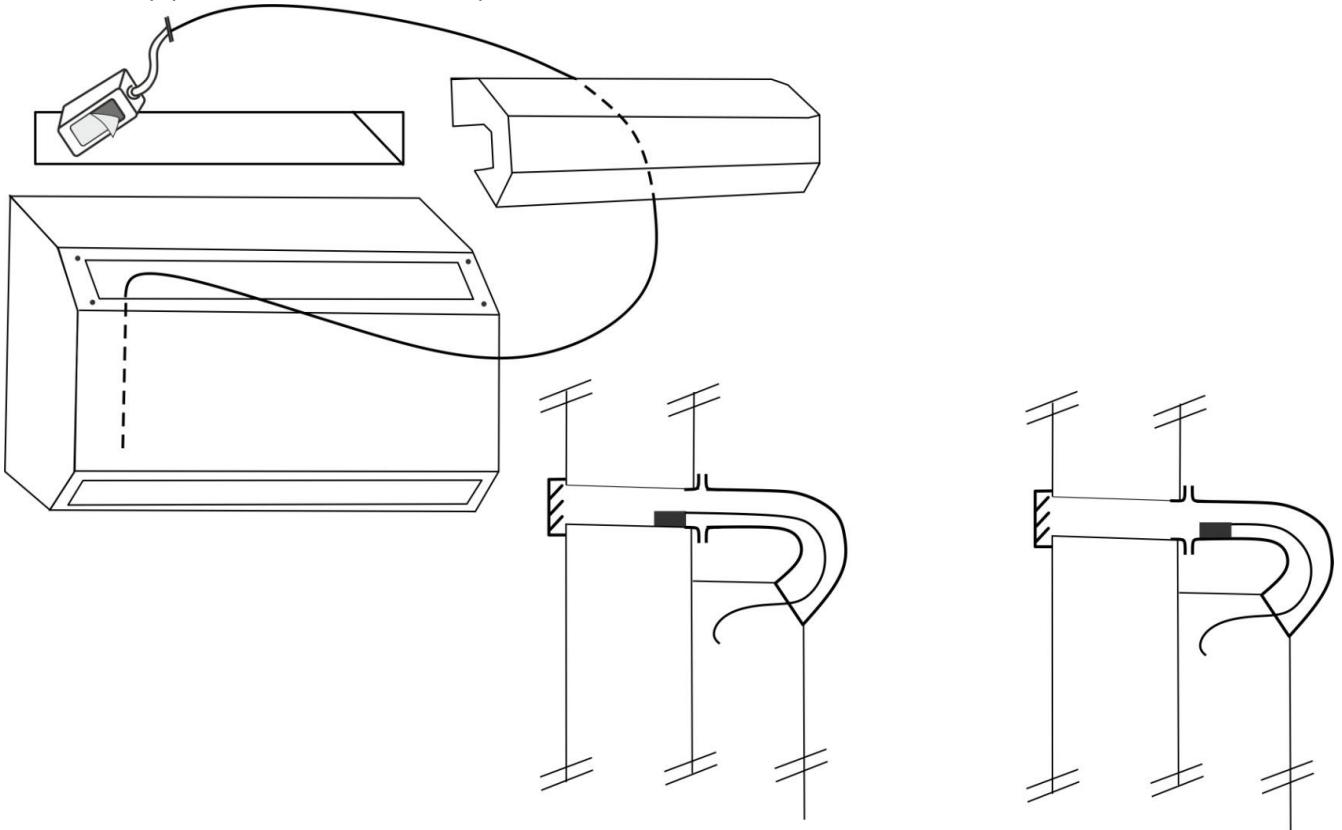

C: If your dehumidifier is also equipped with an electric heater, place the antenna on the outside of the cover. After starting the dehumidifier, test whether the signal is successfully transmitted between the transmitter (display unit) and the antenna. For example, if you set the humidity lower than the current value, then the dehumidifier will start up into its full operation within 3 minutes. The signal is designed to pass successfully over a distance of about 100 meters, through an aluminum fence or steel-reinforced concrete wall. However, the individual conditions of a particular installation may be different. If there is no signal transmission, place the antenna in the lower (suction) air ducting.

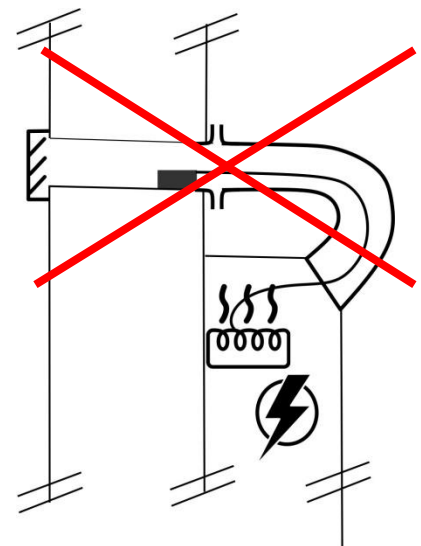

4.3 Humidity control by external wired humidistat EBERLE

If your device is equipped with an EBERLE wired remote humidity controller, pay attention to this section of the installation manual.



Wired humidistat EBERLE HYG6001



Wired humidistat and thermostat EBERLE HYG7001

The dehumidifier can be equipped with a remote humidistat on request. In this case, the dehumidifier has two humidity controllers. One of them is a built-in mechanical humidistat inside the pool dehumidifier, the other is an external wired humidistat. The dehumidifier is controlled primarily by the remote humidistat, provided that the built-in humidity controller inside the dehumidifier is set to a higher desired humidity value than the remote humidistat.

If your dehumidifier is equipped with a hot water element and/or a solenoid valve also, you must use a humidistat with an EBERLE HYG7001 thermostat to activate the dehumidifier's air heating function, or you must have an external thermostat connected.

4.4 Fan regulation

Under the inner cover of the device there is a two-position fan mode switch. In the first position, the fan runs even if the compressor of the device does not, it is a so-called **CONTINUOUS mode**. In the second position, the fan runs simultaneously with the compressor, it is a **PERIODICAL mode**. The continuous operation mode of the fan is more optimal, as the built in humidity sensor continuously senses the humidity, which achieves higher accuracy. At the same time, the continuous operation of the fan mixes the air in the room better. The fan control is set by the installation company according to the user's requirements. DRY300-400 models are equipped with only one fan speed and, in the case of continuous operation, the fan is still running at full speed. DRY500 is equipped with two speeds. In the case of continuous operation while the compressor is switched off, the fan runs at low speed, which effectively mixes the air in the pool hall.



CONTINUOUS DUTY OF THE FAN

PERIODICAL DUTY OF THE FAN

4.5 Compressor control

The start of the compressor is delayed by 3 minutes due to its protection. Depending on the humidity and ambient temperature, this may take longer. If the compressor stops, it will start automatically after 3 minutes at the earliest. The user must not manipulate the setting element of this time protection. The task of time protection is to equalize the pressures of the refrigerant in the dehumidifier's system.



After a long period of inactivity, it is normal for the compressor to try to start 4-6 times before finally turning on. It also depends on the current air temperature. A lower ambient temperature (approx. 22°C) requires more attempts, a higher temperature (approx. 30°C) usually requires only 1 attempt.

5. INSTALLATION MANUAL



Please note that the screws and dowels supplied with the appliance may only be used on a solid concrete or a brick wall. Please check the base material and select suitable screws and dowels.



The appliance must be installed in accordance with national installation and wiring regulations!



The location of the device must be in accordance with the STN 33 2000-7-702 standard. It is recommended to place the device outside zones 0,1 and 2. When placing the device in zones 2 or 1, the STN must be observed.



It is necessary to place the device outside zones where cleaning with spraying water is expected. Connection to the electric network and protection must comply with relevant standards. The power supply of the device must be realized by a protective isolating transformer or protected by a residual current device with a rated residual breaking current not exceeding 30 mA when installed in rooms where water can be found.

5.1 Device Location

ZONE 1, IPX4

**Pools that are not cleaned
by water jet**

at a distance of 1250 to 2000 mm from the edge of the pool

they must comply with STN and at least 300 mm from the floor.

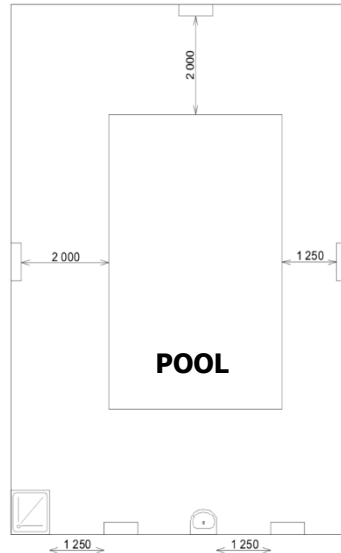

ZONE 2, IPX2

**Pools that are not cleaned
by water jet**

at a distance of 2000 to 3500 mm from the edge of the pool must be in accordance with STN and is required min. 150 mm elevation above the floor due to sufficient airflow, installation of the device on the floor is prohibited.

OUTSIDE ZONE

at a distance of less than or equal to 1250 mm from the edge of the pool, the lower edge of the device must be at a height of 2500 mm from the surface of the pool, if it is recessed under the floor or from the floor.

min. 1250 mm (i.e. out of reach) from the side edge of the shower enclosure, cannot be above the shower enclosure.

min. 1250 mm (i.e. out of reach) from the side edge of the sink at a height of min. 1200 mm from the floor, cannot be above the sink.

OUTSIDE ZONE

at a distance of min. 1500 mm from the vertical plane around the jumping platforms, jumping boards and starting blocks and 2500 mm above the highest surface on which people are expected to be present.

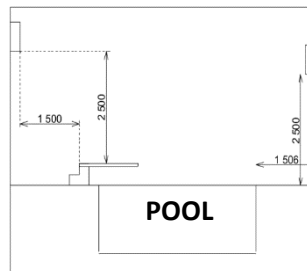

OUTSIDE ZONE

if the unit is at a distance less than or equal to 1250 mm horizontally from the edge of the pool, then it must be lifted 2500 mm from the surface of the pool, if it is recessed under the floor and from the floor.

DRY 300, DRY 400 and DRY 500 WAVE are designed to be installed directly in the pool hall. All models are protected by electrical protection class IP44.

1. In order to be as efficient as possible, the appliance must be installed as high as possible but not completely below the ceiling. It is forbidden to install the device on the floor, as the air intake into the device is from below. It is necessary to ensure good air flow, for which it is necessary to leave free space of min. 150 mm under the device and min. 200 mm above the device. Due to maintenance, it is also necessary to leave free space of min. 200 mm on the sides of the device.

2.

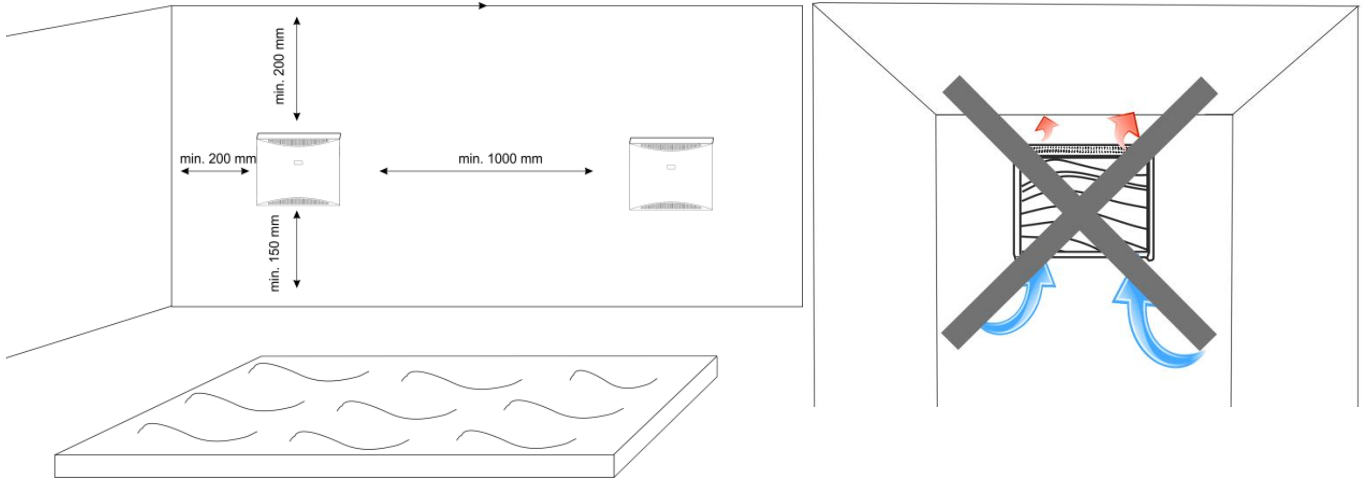

3. It is not advisable to mount the dehumidifier close to heating elements, as the dehumidifier could suck in heated air and this could delay its regulation. Also, placement above, for example, a radiator can cause the device to overheat, malfunction, or be damaged. It is also not advisable to place the dehumidifier near open windows, as it could suck in outside air and it could also delay its regulation. The suction of outside air causes the moisture from the pool hall not to be resolved and thus to accumulate in the pool hall.

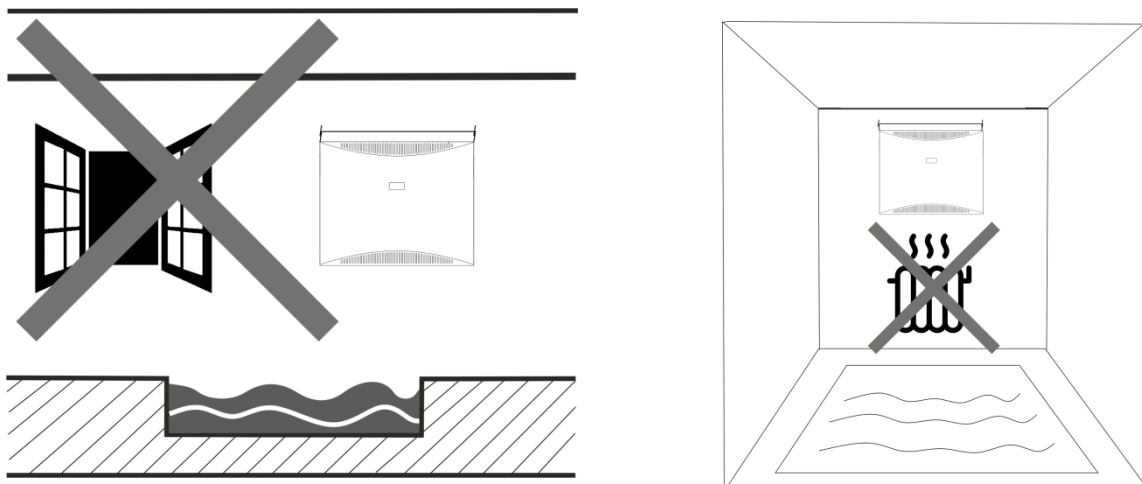

4. If two dehumidifiers are used in one room, it is recommended to install the devices further apart to ensure correct air flow in the pool hall and to achieve the desired humidity control effect. Installation too close to each other can cause dry air to circulate between the devices. This can result in excessive humidity in part of the pool hall. We also recommend maintaining a distance of at least 1 meters between the devices for future installation and service.

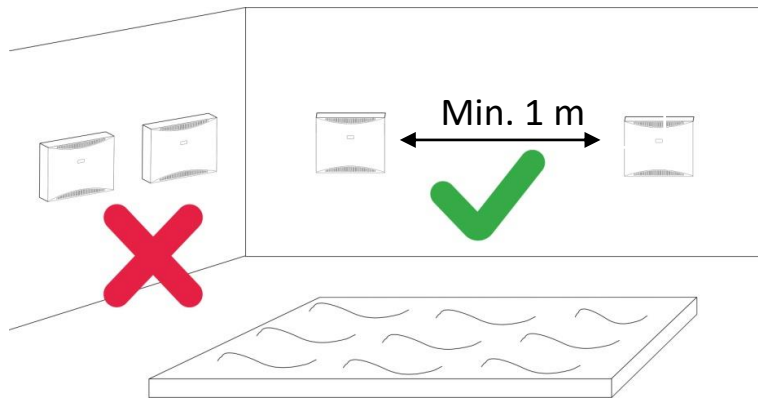

5. Always install the dehumidifier so that it can dehumidify pool air. In case of a structured pool hall, or a separate part – the placement of a dehumidifier is not suitable as the air flow will not be sufficient, thus the desired dehumidification effect may not be achieved.

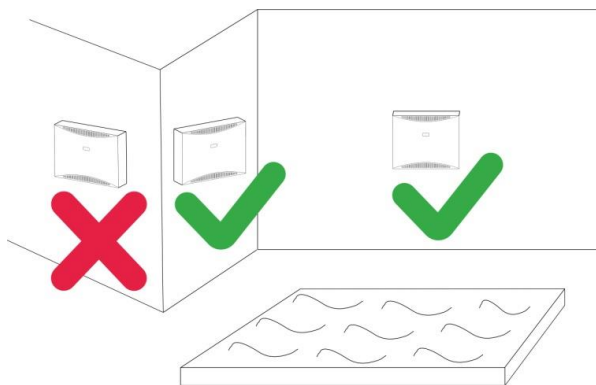

5.2 Device fixation

A DRY 300 / DRY 400 / DRY 500 accessory is a mounting bracket that must be fixed to the wall with the supplied screws and dowels. The device has a self-supporting construction. The axis of the mounting holes is 210 mm lower than the upper edge of the device. The three mounting holes are 360 mm apart. When the bracket is attached, the device can be hung without removing the cover.

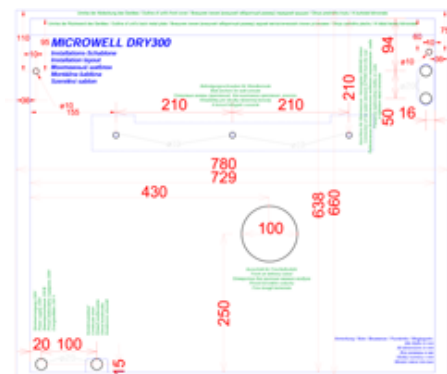

Please use the enclosed mounting template.

5.2.1 Mounting template

The mounting template is a large sheet of paper that is processed in a scale of 1: 1 ratio of the size of the dehumidifier. Includes marking of dehumidifier drawing, wall bracket with screw holes, fixing screws, water drain, power supply and LPHW connection from behind. Proceed by placing the

mounting template on the wall where the dehumidifier will be mounted - make sure that the holes in the wall bracket are balanced with a spirit level. Punch and mark them on the wall in the places indicated for drilling. When positioning the holes, pay attention to the location of the electricity supply and the condensate drain!

5.2.2 Brief installation instructions

Determine a location for mounting the dehumidifier. Choose a suitable position respecting all the rules described above.

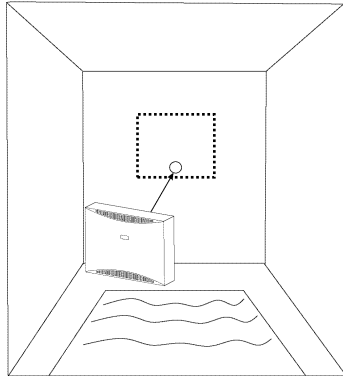

1. Place mounting template on the wall. Before installing the Athmos cleaner, all construction work (painting, tiling, heating, drainage, electricity, etc.) must be completed.

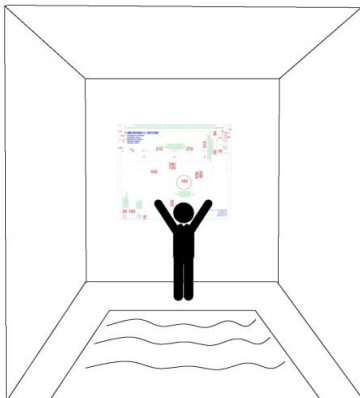

2. Using the mounting template and spirit level, mark all the holes that will need to be drilled. Remember to use a spirit level. For safety reasons, it is recommended to fasten the device with two more screws in the upper right and upper left corner - the location can be found on the installation template.

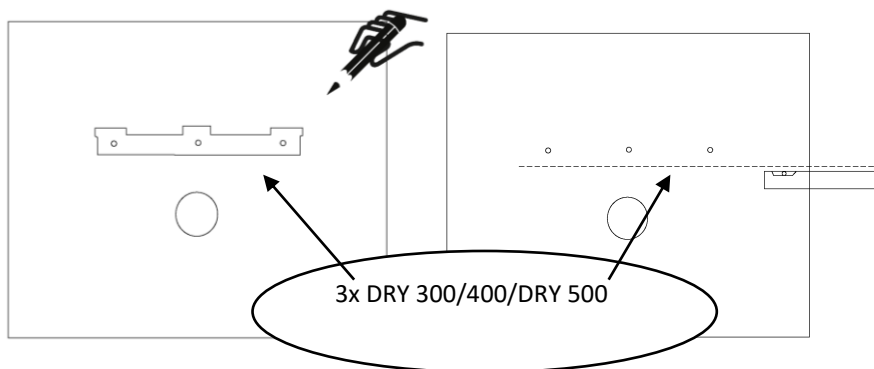

3. You must drill: **3 holes for the DRY300/400/500 wall console, 2 holes for the DRY300/400/500 fixing screws, an opening of \varnothing 100mm for DRY300/400/500 fresh air supply** (in case your dehumidifier is equipped with this accessories, which is available on request).

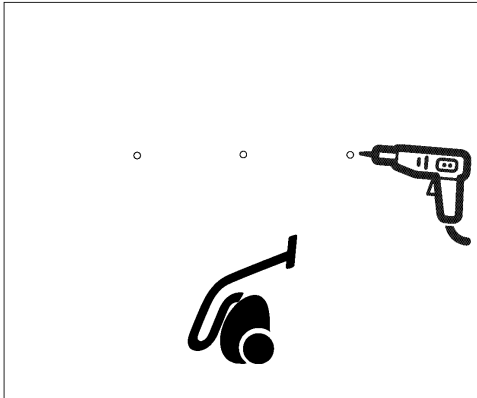

- 4. Drill the holes. We recommend vacuuming the dust.
- 5. Insert supplied fasteners in the holes.

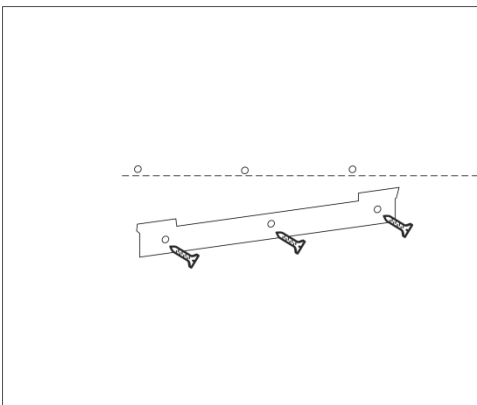

- +/- 0.3%**
- 6. Secure console with the supplied or other suitable screws.
The console must be in a horizontal position with a maximum deviation of +/- 0.3%!

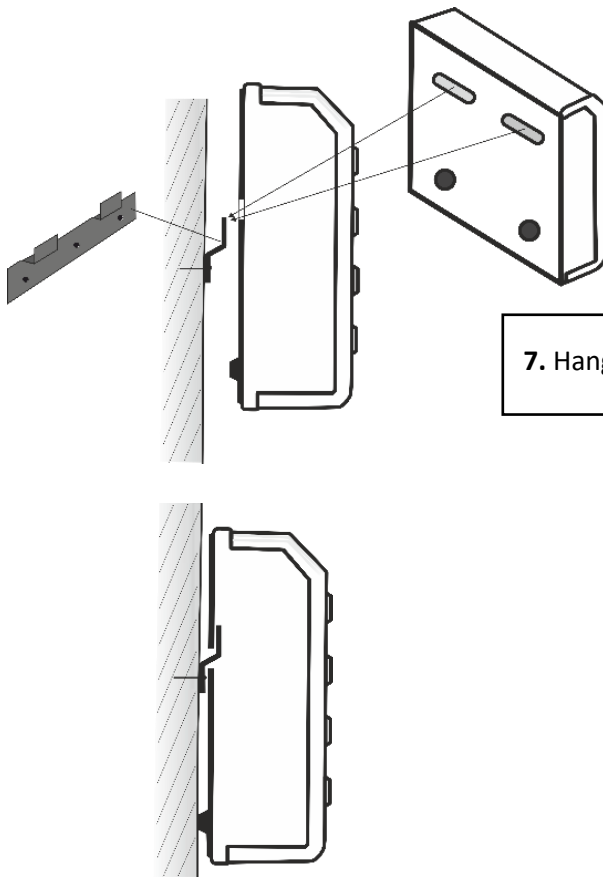

- 7. Hang the dehumidifier onto the console.

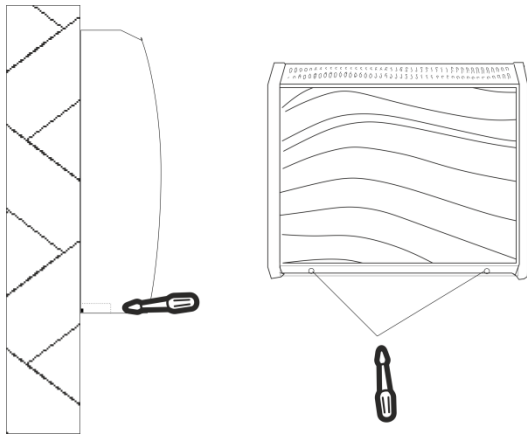

8. You will now need to remove the cover of the dehumidifier, to connect the power supply and condensate drain. The cover can be removed after loosening 2 screws (DRY 300/400 Wave) or 3 screws (DRY 500 Wave) on the bottom part of the device.

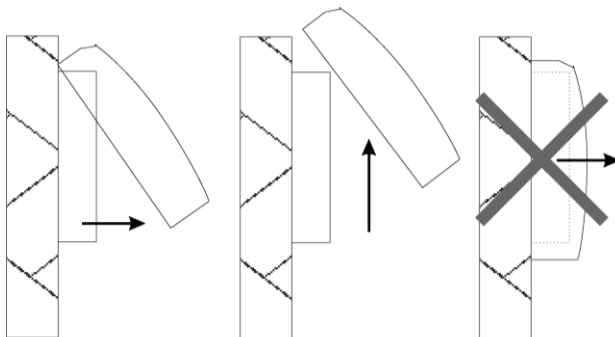

9. Pull the lower part of the cover towards yourself and then lift it down to remove the cover from the back plate. **Do not pull the cover towards yourself without lifting it first!**

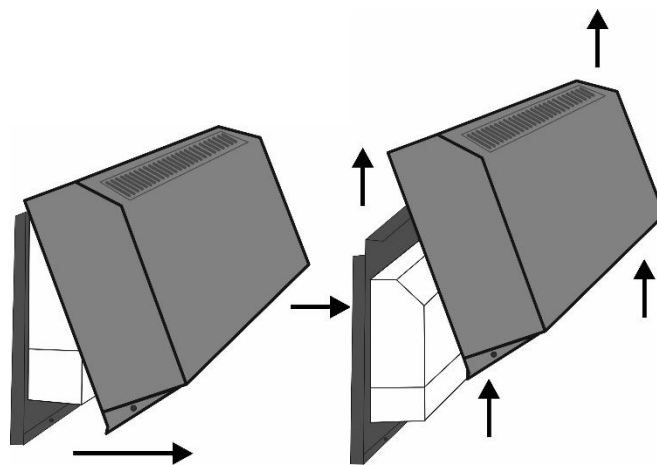
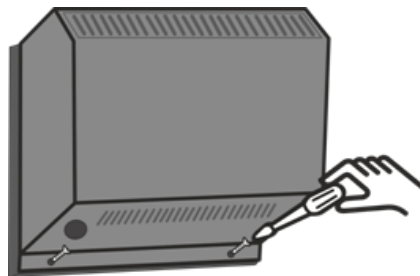

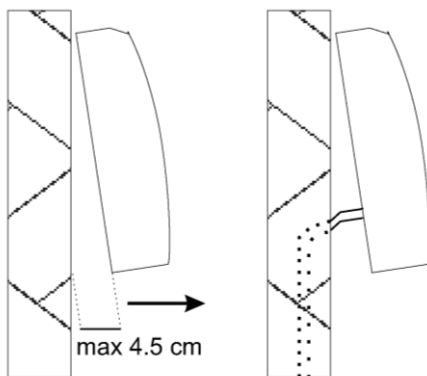
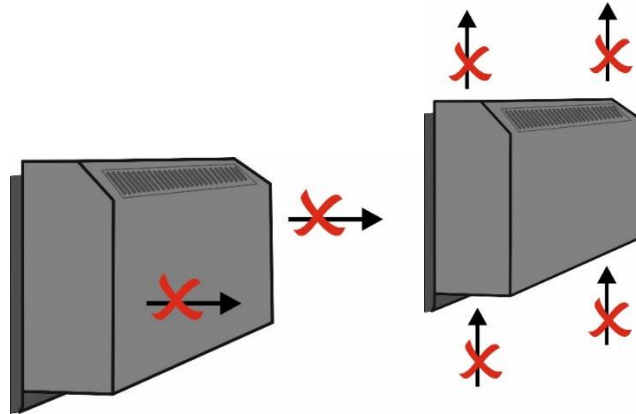

10. In the lower left part, there is a condensate drain hose, which must be inserted into the sewer pipe (rear). **Never drain condensate into the pool, it may contain dangerous bacteria.** The lower part of the dehumidifier can be slightly pulled together and thus have access to the condensate. Follow section 5.3 Condensation drainage when installing the condensate hose.

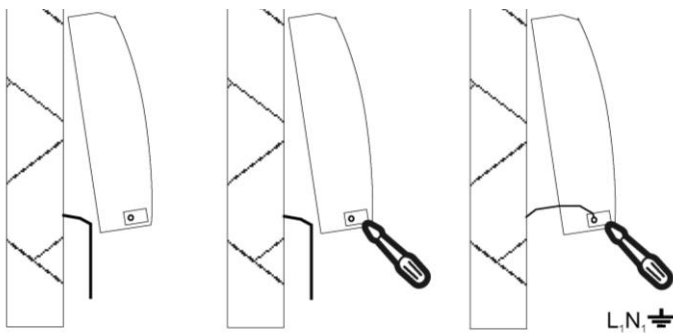

11. Connect the power cord. For this purpose, there's an adaptor formed on the back plate of the device. The device is connected to 230VAC/1φ L,N, grounding ⚡ . Please follow section 5.4 Main power supply connection.

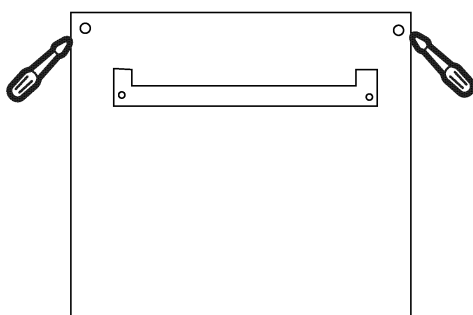

12. Set fan mode (4.4 Fan regulation).
13. After successful set-up of the dehumidifier, it is necessary to fix it with fixing screws. These are not part of the package and must be selected according to the type of wall or mounting structure.

14. Put the cover back on the device. Follow point 9 in reverse order.
15. Switch on the circuit breaker to supply voltage to the dehumidifier's power supply. This turns on the device. If you have set the fan to run continuously, it will turn on immediately. If the set humidity is lower than the actual humidity, the compressor will also start after approx. 3 minutes. You will hear a gentle vibration. Do not drain the dehumidifier without the main cover. **This condition can cause back ventilation, virtually instant freezing of the device and damage.**
16. If the dehumidifier works properly, the installation is complete. If the pool hall has not yet been completed, we recommend switching off the dehumidifier with a circuit breaker and wrapping the dehumidifier in plastic foil. This will prevent dust and construction waste from entering the device. More instructions in section 5.3. Condensed water drainage

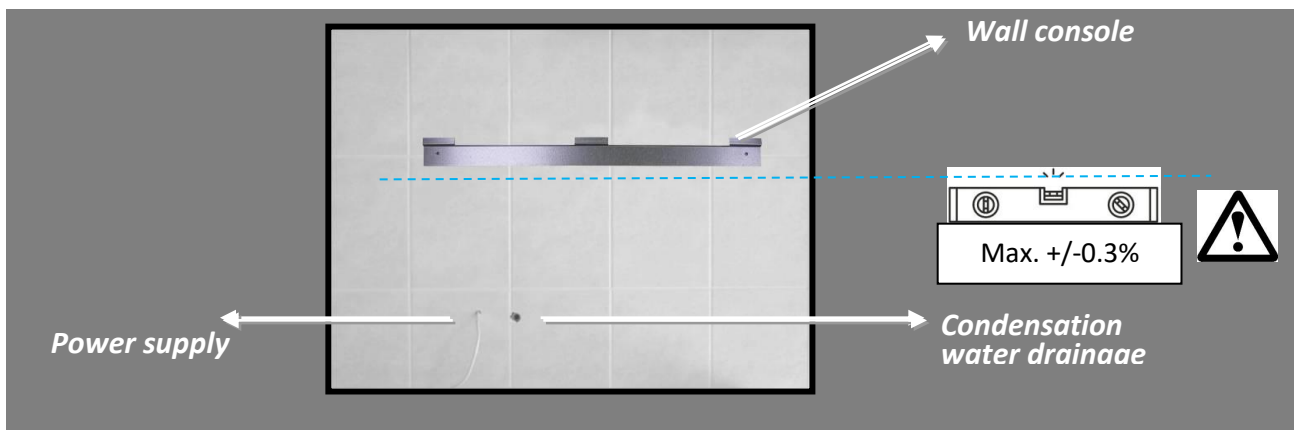

Pic: DRY 500 installation preparation

5.3 CONDENSATION WATER DRAINAGE

When drying your pool hall, your dehumidifier will condense the water that is fed into its internal collection tray. Without active (free) condensate drainage, the dehumidification process will not work. Condensation water is drained from the dehumidifier by gravity (downwards). The condensing tray has the correct slope when the dehumidifier is mounted horizontally (using a spirit level). Condensed water must be drained through a siphon to the sewer or to the outside environment. Please do not place the drain hose upwards (against gravity), as this may cause the appliance to be unable to drain water condensate. This in turn will cause water to leak from under the unit cover and may lead to unit failure, damage, or failure. It can also cause the floor to get wet, creating the risk of injury and damage to health from unwanted slipperiness. The manufacturer, distributor or dealer is not liable for such damages. We recommend using the HL 138 concealed siphon designed for air conditioning units in the condensate drain. This must be located min. 20 cm below the condensate outlet from the dehumidifier. The pictures below show more.



Warning:

Condensed water from the dehumidifier must not be collected in the collecting container drunk!

Condensed water from the dehumidifier must not be returned to the pool!

HL138 0,15 l/s
DN 32

1. Ø20-32mm
DN32

2.

3.

4.

5a.

5b. min. 20 cm

6.

DE KLIMAGERÄTE - EINBAUSIFON H KLÍMAZFON FALBA SÜLLYESZTVE CZ/SK PODOMÍTKOVÝ SIFON PRO KLIMATIZ JEDNOTKY TR SPLIT KLÍMALAR İÇİN GÖMME SIFON
 IT SIFONE AD INCASSO PER CONDENSATI PL SYFON PODTYNKOWY DO SKROPLIN HR UGRADBNENI SIFON ZA KLIMA - UREĐAJE PYC СИФОН ДЛЯ КОНДИЦИОНЕРОВ
 GB IN-WALL CONDENSATE SIPHON SI VGRADNI SIFON ZA KLIMA NAPRAVE RO SIFON DE CONDENSATIE BUL КОНДЕНЗАТЕН СИФОН ЗА ВЪРЖДАНЕ

03.08.2011

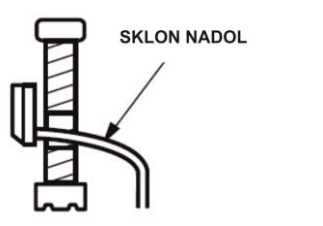

Proper installation of condense hose

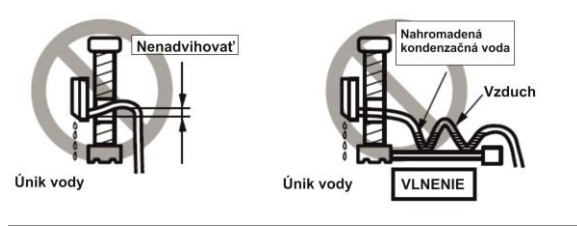

Improper installation of condense hose

CONDENSATE DRAIN

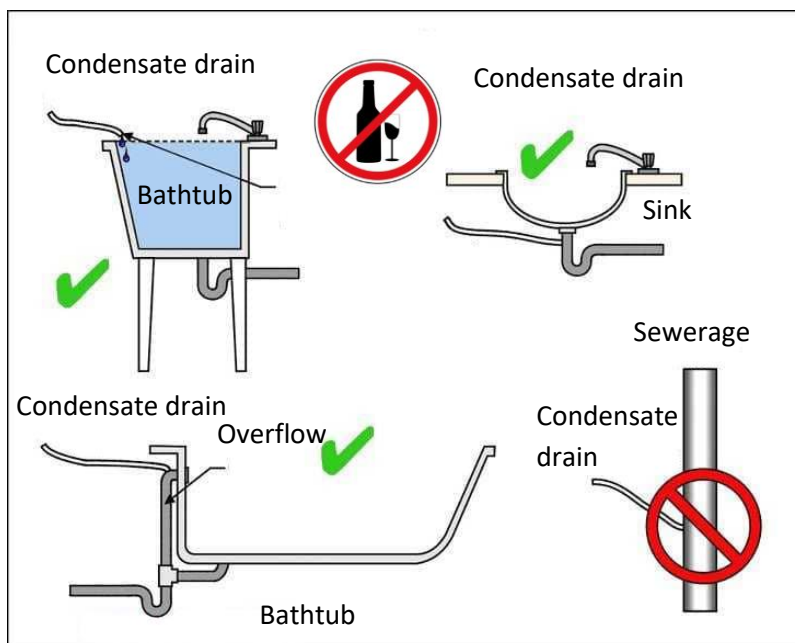

5.4 Main power supply connection

ELECTRICAL CONNECTION FOR PREMIUM THROUGH THE WALL

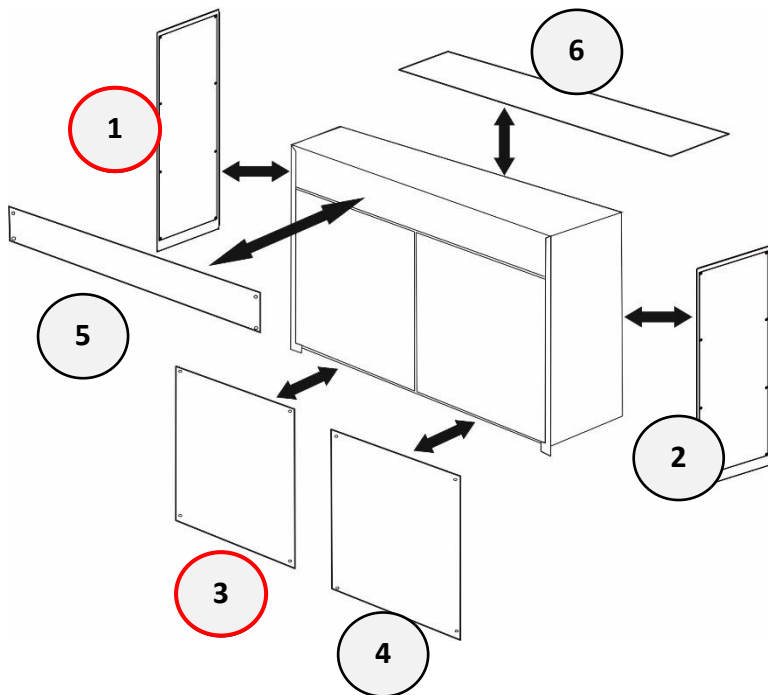

Position	Component
1-Left side	Electro set
2-Right side	Expansion, LPHW, Connection, 4-way valve
3-	Compressor + Electro box
4-	Evaporator + Condensate tray, Fan Coil
5-	Condenser, LPHW, El. coil
6-Top	LPHW, El. coil, Condenser

In order to access the unit's electro wiring box and/or main electrical connection terminal you only need to demount metal parts number 3 and/or 1.

Your Microwell DUCT dehumidifier allows you to access, inspect, maintain or service inner parts of the dehumidifier without necessity to de-install the air ducting and/or unit main chassis cover. This allows the maintenance or service to be easier and faster. Each compartment is affixed with 4 or 6 screws.

5.4.1 Main electrical connection for fixed cable in wall

As standard, the dehumidifiers are connected to a fixed cable in the wall. Connecting the device to an el. network must comply with the relevant security standards. Connection requirements are: Power supply: 220-240 V / 50 Hz / 1f. Fuse: 16A (DRY 300/400/500) with residual current device (RCD) with a rated residual current not exceeding 30 mA. The main switch of the device must be located outside the pool hall. The main switch of the appliance must be bipolar with the switch of the L and N wires. The appliance must be placed on a solid surface to disconnect the appliance from the mains. The distance between the contacts, when switched off, must be at least 3 mm for all poles.



The appliance must be connected to the mains by a certified electrician.



Mind all electrical safety precautions.

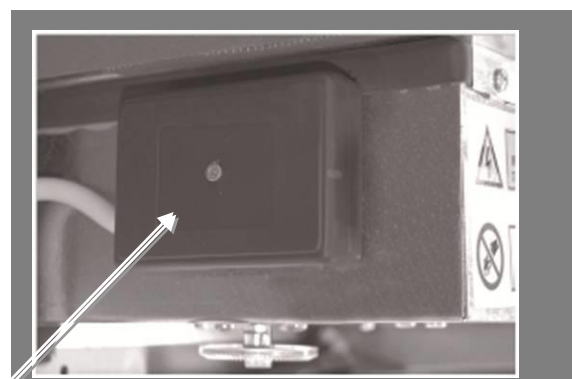

The mains terminal block is located in this black box

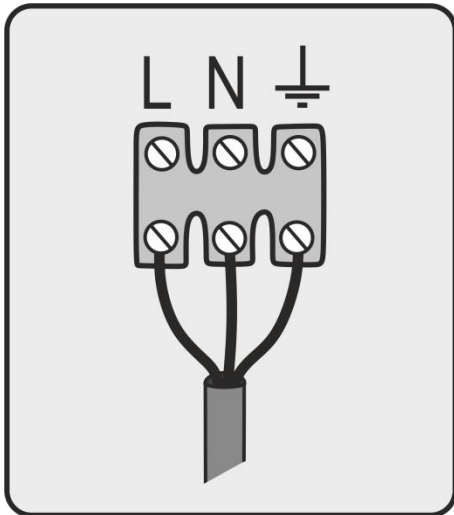

Standard terminal block -
L, N, ground

Main power supply		
Dehumidifier type	El. cable	El. insulation
DRY 300	CYSY 3x 1,5 mm ²	10 A typ C
DRY 400	CYSY 3x 1,5 mm ²	10 A typ C
DRY 500	CYSY 3x 2,5 mm ²	16 A typ C

El. connection of a potential-free contact for a cooperating hot water heating system		
Dehumidifier type	El. cable	Power supply
DRY 300/400/500	CYSY 2x 1,5 mm ²	via contactor

Electric heating element connection		
Dehumidifier type	El. cable	El. insulation
DRY 300/400/500	CYSY 3x 2,5 mm ²	16A

El. connection of wire humidistat and thermostat	
Model	El. cable

HYG6001	CYSY 4x 1,0 mm ²
HYG7001	CYSY 5x 1,0 mm ²

5.4.2 El. connection of external humidistat and thermostat

The connection of the EBERLE HYG6001 (HYG7001) cable remote humidistat is made at the installation site. The manufacturer does not supply the connecting cable.

EBERLE HYG6001 connection for DRY 300/400

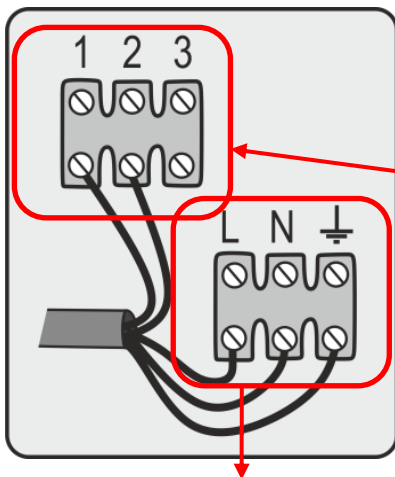

HYG-E 6001

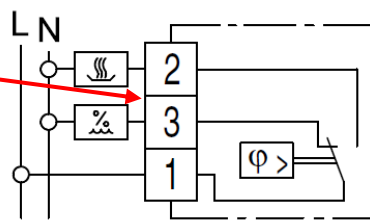

MAIN ELECTRICAL CONNECTION OF THE DEHUMIDIFIER

230V/50Hz/1f
3x 2.5mm² CYSY
breaker 16A type C
circuit breaker 30mA



HYG-E 6001

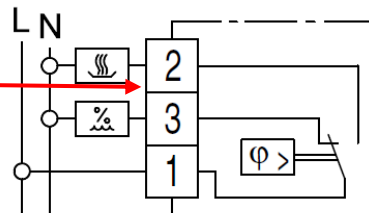
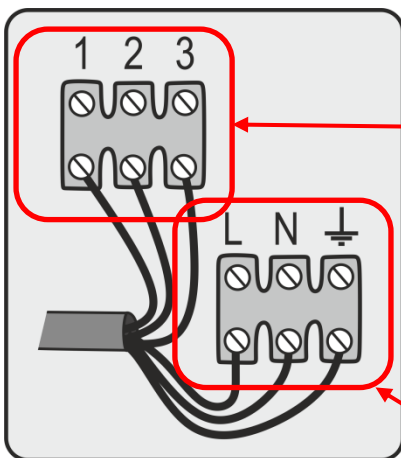

Black box from the SIDE of the electrobox

MAIN ELECTRICAL CONNECTION OF THE DEHUMIDIFIER

230V/50Hz/1f
3x 2.5mm² CYSY
breaker 16A type C
circuit breaker 30mA

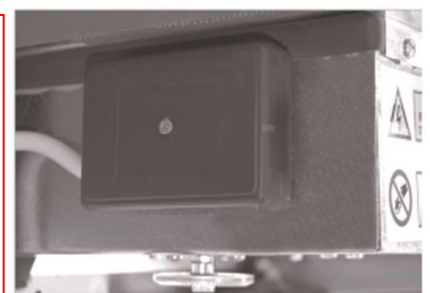

EBERLE HYG7001 connection for DRY 300/400

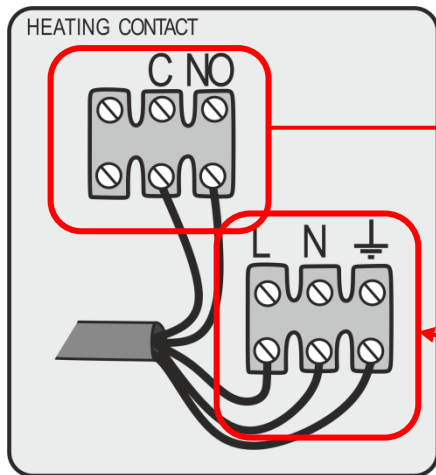

Black box from the SIDE of the electrobox

POTENTIAL CONTACT

- NO /opened normally/
- If the air is heated, then C / closed /

MAIN ELECTRICAL CONNECTION OF THE DEHUMIDIFIER

- 230V/50Hz/1f
- 3x 2.5mm² CYSY
- Breaker 16A type C
- Circuit breaker 30mA

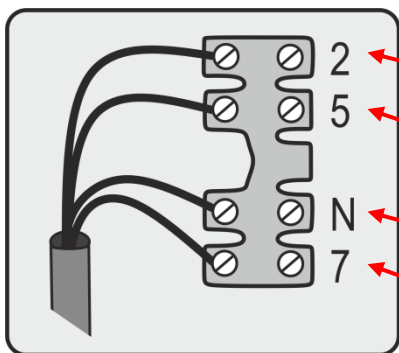

Black box from the FRONT of the electrobox

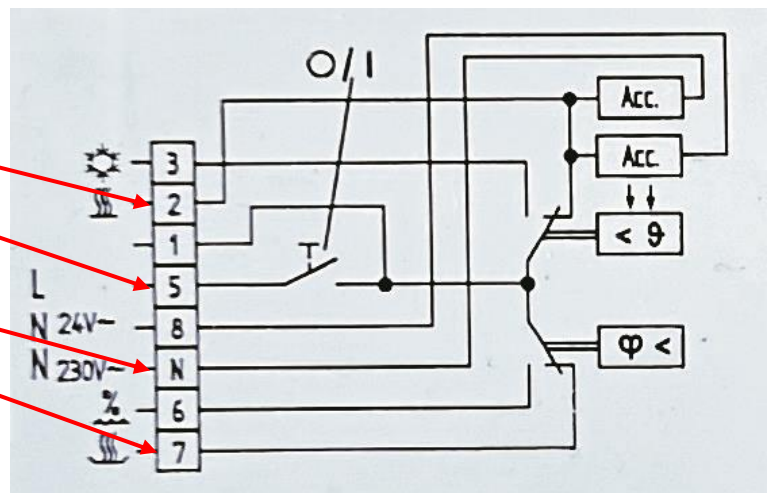

EBERLE HYG7001 connection for DRY 500

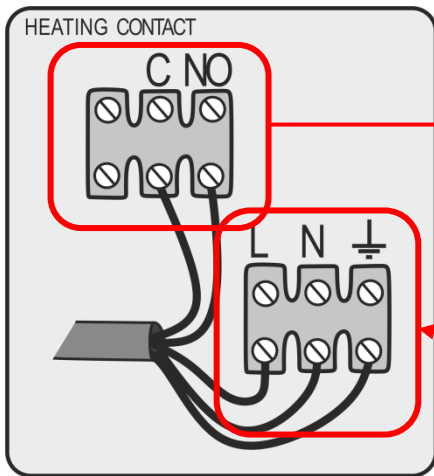

Black box from the SIDE of the electrobox

POTENCIAL-FREE CONTACT

- **POTENTIAL CONTACT- NO /opened normally/**
- **If the air is heated, then C /closed/**

MAIN ELECTRICAL CONNECTION OF THE DEHUMIDIFIER

230V/50Hz/1f
3x 2.5mm² CYSY
breaker 16A type C
circuit breaker 30mA

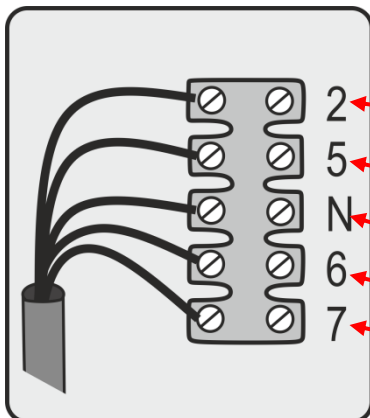

Black box from the FRONT of the electrobox

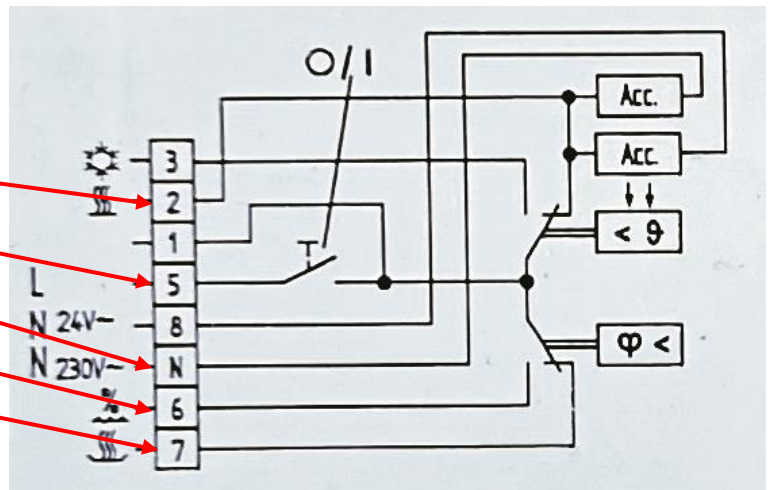

Electric heating element connection for DRY 300/400/500

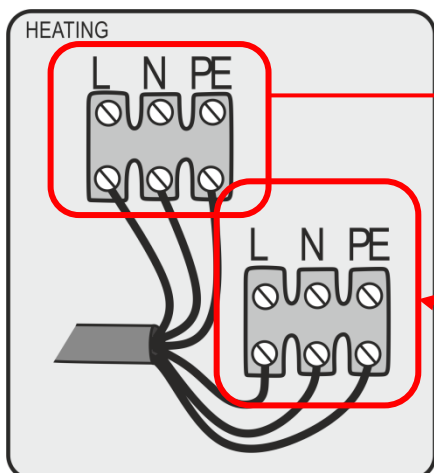

EL. HEATING POWER SUPPLY

230V/50Hz/1f
Kábel: 3x2.5mm² CYSY
Príkón: 2kW (DRY300/400), 3kW (DRY500)
Istič: 16A

MAIN ELECTRICAL CONNECTION OF THE DEHUMIDIFIER

230V/50Hz/1f
Cable: 3x 2.5mm² CYSY
Breaker: 16A type C
Circuit breaker: 30mA

Black box from the SIDE of the electrobox



The functions and operation of the remote humidistat are described in a separate enclosed manual.

5.4.3 Main electrical connection to the flexible cable to the electrical outlet

Models with a mobile stand on the floor are supplied with a flex cord for connecting a socket up to 220-240 V / 50 Hz / 1f. The socket must be designed for humid environments and separately protected: a 16A circuit breaker (DRY 300/400/500) with a residual current device (RCD) with a rated residual current not exceeding 30 mA.

After placing the dehumidifier with the mobile stand to the place of use, it is necessary to secure the 2 wheels on the front of the mobile stand against movement according to the following Pictures.

Mobile Stand

Your dehumidifier can be used on a mobile stand. Although the dehumidifier is primarily designed for fixed installation on a wall, behind a wall or on the floor, there are applications that require a mobile application. This is achieved using a mobile stand. This is supplied as a metal construction on 4 fully swivel castors, the front two of which have brake protection.

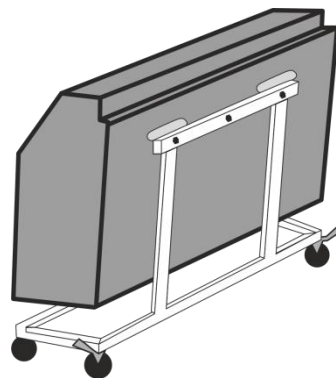

When using the dehumidifier on a stand, it becomes mobile. This means it is meant to physically move in space. Of course, there are risks associated with this due to the very nature of a mobile device, such as: fall or overturning of the device. Doing so may cause injury, personal injury or property damage. The mobile assembly of the device is not a toy and it is not intended for carrying other objects or as a support or base for other objects. When operating a device that is mounted on a mobile stand, keep in mind that the device is mobile, meaning it can move on its own.

For mounting and using the dehumidifier on a mobile stand you will need:

1. Mount the dehumidifier on a wall bracket to be attached to a mobile stand. For DRY300/400/500, the wall bracket is attached to the mobile stand with 3 screws.
2. The mobile stand can only be placed on a surface that is horizontal with a maximum deviation of $\pm 0,3^\circ$. After placing the cleaner, the mobile stand must always have locked

wheels. Wheels can only be unlocked for the least possible time required for actual handling from place to place of Athmoss. In all other cases the wheels must be locked.

3. If the dehumidifier is ordered together with the mobile stand, it is delivered with a 2m power cord with a plug. This can be used with a socket in the pool with a minimum protection of IP44. Please make sure to place the 230VAC device in the correct zone in the pool. Make sure that the fuse of the socket is protected by a circuit breaker as described in the rest of this user and installation manual. Odvod kondenzátu zabezpečte tak, ako je to popísané v ostatnej časti tohto užívateľského a inštalačného manuálu.
4. Move carefully around the dehumidifier on the mobile stand and make sure that it is not raised, overturned or moved. The manufacturer, distributor and seller are not liable for damage to health and property caused by improper handling or placement of the device.



Picture: After moving Athmoss on the mobile stand to the application site, secure the wheel brake (locking). The wheel brake is locked when the brake lever is down. The wheel brake is released when the lever is up.

Securing wheel brake	Releasing wheel brake

Fixed stand - Installation



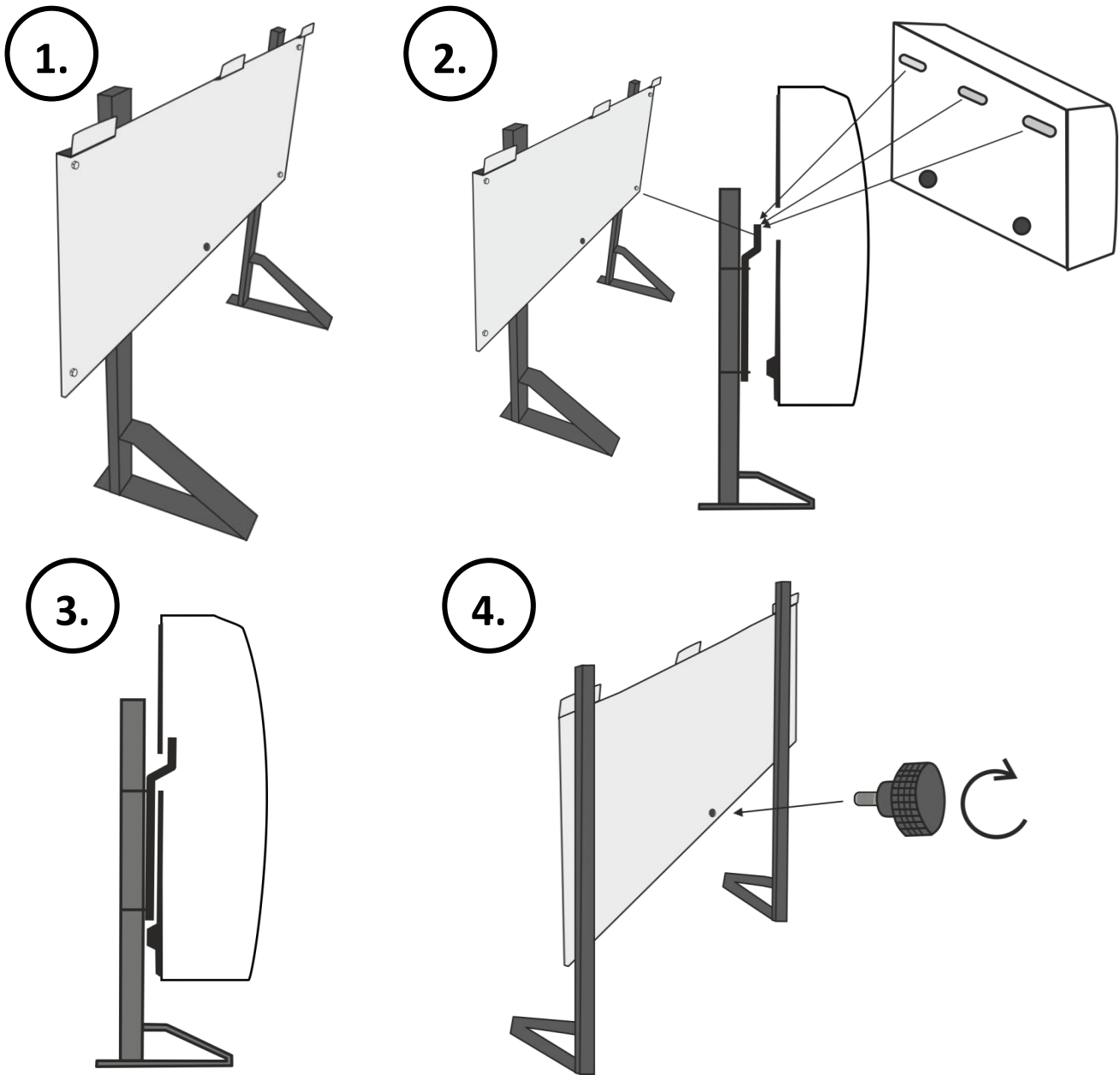

The dehumidifier is designed for placement on a surface with a height deviation of max. 0.5% +/-.

5.5 LPHW hot water heating element for additional heating – on request

The LPHW heating element is only available on request. The connection of the LPHW hot water insert is made similarly to the connection of the radiator. A control valve is connected at the inlet and a shut-off valve with a screw connection at the return. These are supplied by the heating supplier.



Image: Solenoid valve with coil - used in LPHW with regulation; Water circuit connection ½" inner

Recommendation: Install valves in front of the dehumidifier to disconnect the hot water insert from the appliance; Water circuit connection ½" inner

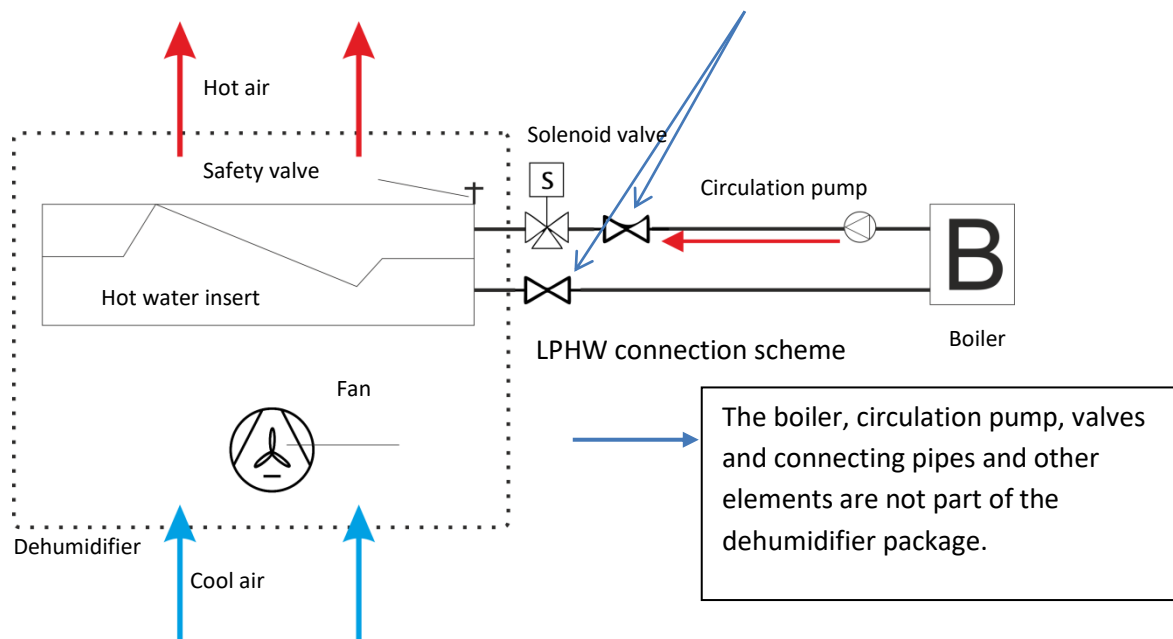

Please note that DRY 300/400/500 are not equipped with a thermostat and a potential-free heating contact by standard.

If your dehumidifier is equipped with a hot water element and/or a solenoid valve, you must use a MICROWELL DRY EASY300 wireless humidistat and a thermostat with an EBERLE HYG7001 thermostat to activate the air heating function with a dehumidifier, or you must have an external thermostat connected. The reason is that the built-in mechanical humidistat or cable remote humidistat EBERLE HYG6001 does not have a thermostat function. An external thermostat is not included in the package of this product.

If your dehumidifier is equipped with a hot water element and your dehumidifier is designed without a remote wireless humidistat with a thermostat, there is a risk of the dehumidifier overheating. Overheating can occur if hot water flows into the LPHW hot water insert even when the dehumidifier dehumidification is not running (fan off). Under normal circumstances, a remote humidistat with a DRY EASY300 thermostat and an original solenoid valve regulates the water supply automatically, effectively preventing the dehumidifier from overheating. It is therefore necessary to use a thermostat to control the heating in the appliance. Neither the manufacturer nor the distributor is liable for damages resulting from non-compliance with the above instructions.

Parameters of the solenoid valve:

- dimension DN 12,
- operating pressure PN 10,
- threaded connection,
- control: coil
- 230V (D-233),
- material: brass,
- controlled directly,
- type: 8253 12D 1 12 2 1 230V AC

No.	Item	Material
1	Safety nut	Galvanized steel
2	Washer	Galvanized steel
3	Coil	PBT + 30% G.F
4	Piping	Stainless steel AISI 430
5	Seal	FPM
6	Screw	Stainless steel
7	Cover	Brass CW 617 N
8	Spring	Steel
9	Ring	Stainless steel
10	Piston	Stainless steel
11	Spring	Steel
12	Support	Stainless steel
13	Insulation	NBR
14	Spring	Steel
15	Cover	Stainless steel
16	Membrane	NBR
17	Cover	Stainless steel
18	Body	Brass CW 617 N

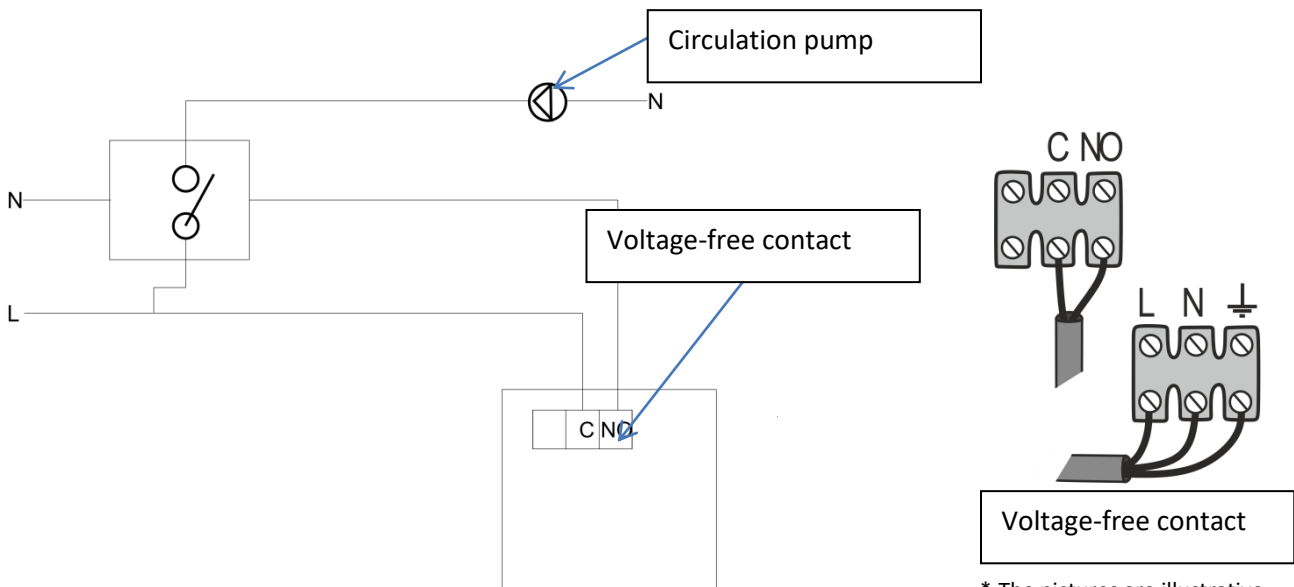
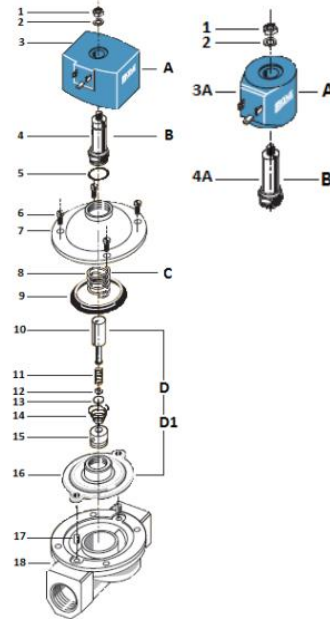

The dehumidifier can be equipped with a solenoid valve on request. When used in combination with a hot water insert, it has a similar function to the fan coil, i. the fan works independently with the compressor (humidistat) and independently with the LPHW hot water insert (thermostat).



It is recommended to insert a shut-off valve between the LPHW hot water insert and the heating source. This will allow it to be quickly disconnected from the heating system in the event of a fault in the heating system and maintenance of the system or dehumidifier.

Heat output of heating element LPHW (W)		
	DRY300/400	DRY500
90/70/30°C	3500	5000
80/60/30°C	3005	4200
70/50/30°C	2240	3350
55/45/30°C	1550	2150
45/35/30°C	665	1005
Water flow (l/min)	5.1	6
Pressure loss (kPa)	12.3	24.1
Water circuit connection	½" inner	½" inner

5.6 Electric heating

On request, your pool dehumidifier can be equipped with an electric heater. It consists of a durable stainless steel tube in an aluminum heat exchanger. Capacity 2kW for DRY300 / 400/500. The electric heater has a separate power connection, which is located in the black box the dehumidifier connection to the power supply located in the dehumidifier electrical box.



The electric heater is equipped with two safety switches. The electric heating is switched on and off according to the set required air temperature on the dehumidifier controller / digital built-in or wireless DRY EASY 300 /.

Please note that the outer cover of the dehumidifier is made of plastic. In the upper part of this cover during electric heating, its temperature can rise up to 65°C (at an air temperature of 35°C). It is therefore forbidden to touch the metal cover at the top of the dehumidifier during operation of the heater. It is also forbidden for children to play with or with the dehumidifier. Please note that children should be supervised by an adult at all times in the room where the dehumidifier is installed.

El. connection of hot water heating element		
El. heating element – power input	El. cable	El. insulation
2 kW	CYSY 2 x 2,5 mm ²	16 A

The device can be equipped with an IP44 power cable. Use an IP44 socket. A socket with a lower degree of protection than IP44 does not guarantee the protection of the dehumidifier.

When using an IP44 power cord and outlet:

- Do not place the plug and socket in humid places or in places with leaking or dripping water.
- Do not place any objects on the cable, do not use the cable for any purpose other than to power the device.
- Place the cable away from other appliances such as radiators, motors, rotors, etc.
- Do not use a dehumidifier if the cord shows signs of damage.
- Always observe the electrical requirements for installation / e.g. breaker.
- Children and unauthorized persons must not manipulate the cable or plug.

5.7 Defrosting by 4-way valve (DRY 300/500)- on request

Defrosting with hot gas allows the dehumidifier to work efficiently at air temperatures as low as 5 ° C. It is designed for demanding operations at low air temperatures. Although the efficiency of the device in terms of extraction rate versus energy consumption at 5 ° C ambient air is low, the dehumidifier will continue to operate normally. If the dehumidifier is equipped with a hot gas defrost accessory, then the gas circuit is equipped with a 4-way valve. When the temperature on the evaporator drops below zero, the system starts counting for 30 minutes. After this time, the evaporator temperature is checked again and if the current temperature is still below zero, the compressor and fan are switched off. The dehumidification then stops. The gas circuit is turned and after 3 minutes the compressor is started. The system now defrosts the appliance for 3 minutes. For another 3 minutes, if the thaw is complete, the unit will return to normal operations. At extremely low temperatures and sufficiently humid air, it is normal for 2 or 3 defrost cycles to take place in succession.

5.8 Air filter - on request

Your dehumidifier can be equipped with an air filter on request. The air filter traps dust and other mechanical particles and prevents them from entering the fins of aluminum heat exchangers. Although the air filter contributes to the cleanliness of the dehumidifier, it does not have the function of an antibacterial HEPA filter. For DRY300 / 400/500 WAVE models designed for wall mounting, it is a fiberglass mesh. In the case of the "behind the wall" design, it is a filter of class G3 or G4.

The operation of your dehumidifier is highly dependent on the continuous supply of air from the environment. It is therefore important to keep the air filter clean. Please read the simple steps below to clean the filter. If the filter is clogged with dirt, it creates a barrier to air supply. The manufacturer recommends cleaning at least once a month. The manufacturer, distributor and dealer are not responsible for damage or malfunction of the device resulting from insufficient cleaning of the air filter.

FILTER REPLACEMENT PROCESS

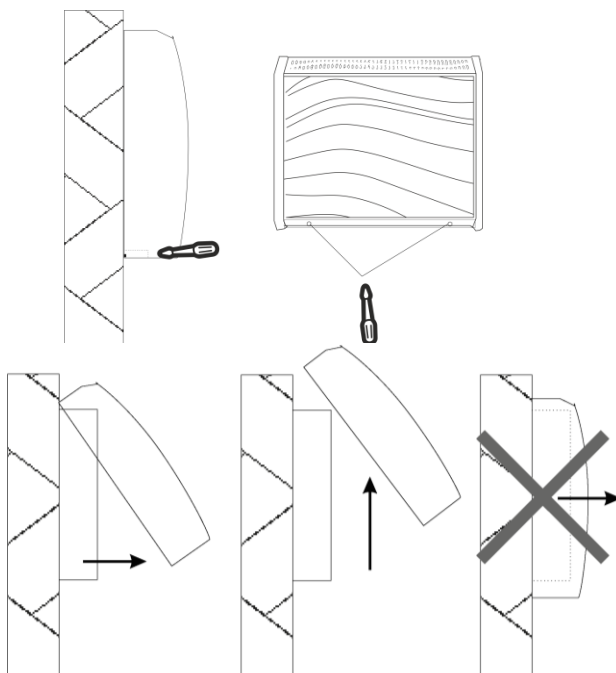

Take the cover off.

2 screws in the case of DRY300/400

3 screws in the case of DRY500



Pull the lower part of the cover towards yourself and then lift it down to remove the cover from the back plate.

Do not pull the cover towards yourself without lifting it!

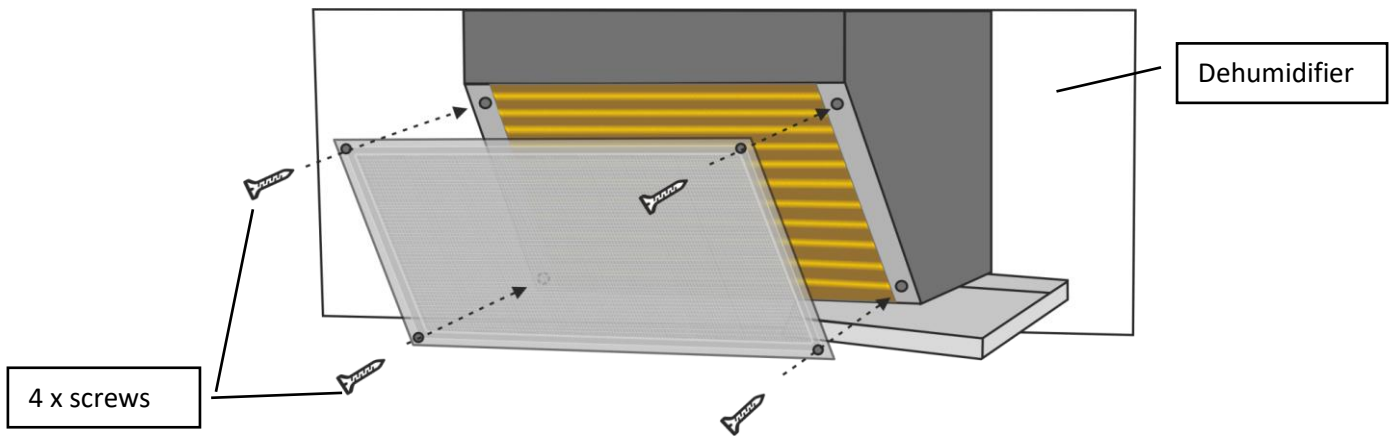

An alternative is an air filter in the wall mounting grille (TTW)

Air filter TTW exchange:

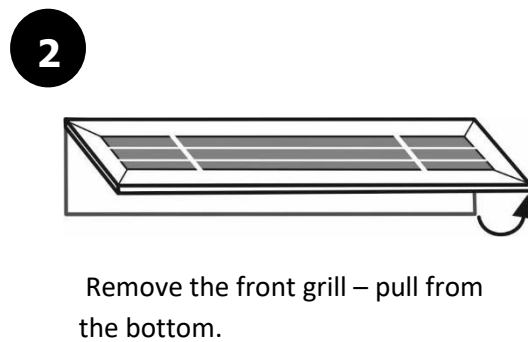
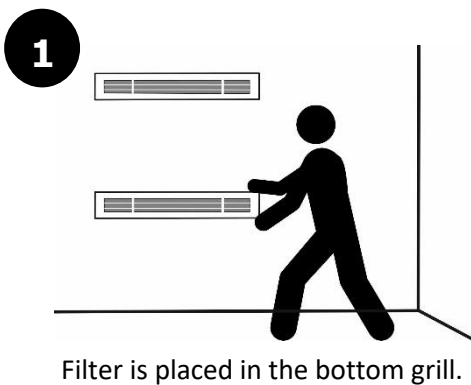
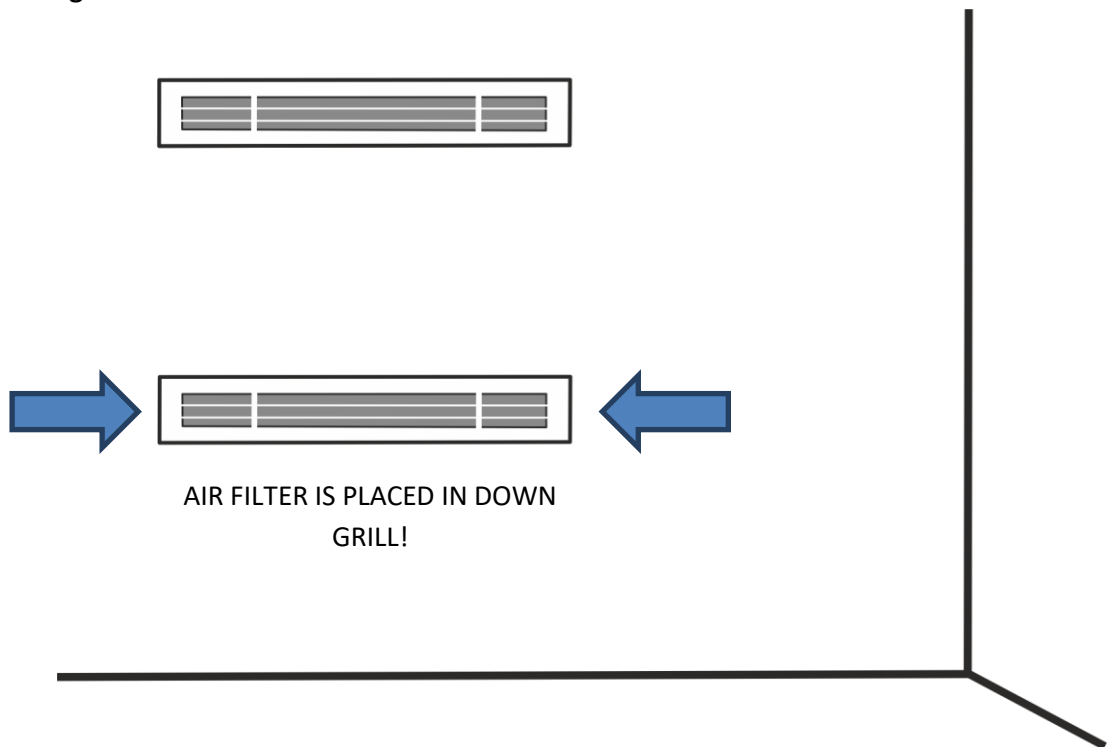

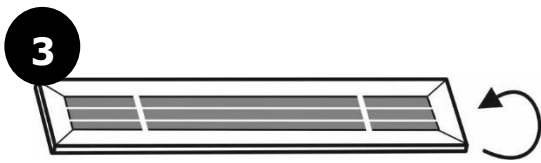

Flip the grill.

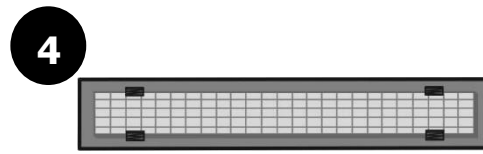

From the back side you will see a metal grill.

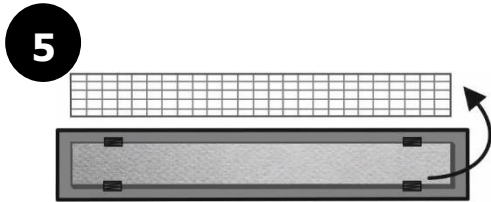

Remove the metal grill.



Remove and Exchange the filter.

5.9 Through the wall installation (TTW) - on request only



DRY 300 TTW a DRY 400 TTW



DRY 500 TTW

Dehumidifiers are also easily adapted for installation behind a wall in a side room. Only two grilles are then visible in the pool hall area. In this behind-the-wall version, pipe extensions are screwed onto the dehumidifier cover. The extensions are supplied in a length for penetration through a 400 mm wide wall. On site, they are then cut to size from the side of the pool hall as needed.

Legend:

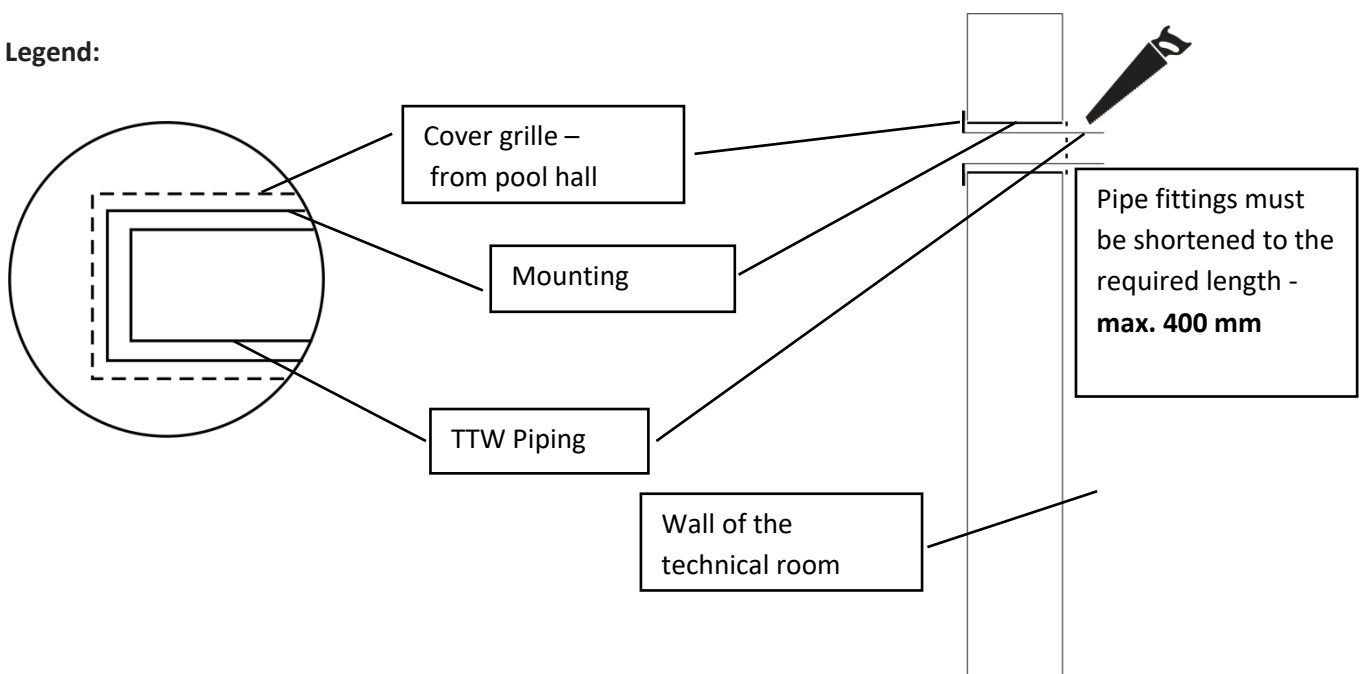

DRY 300 / 400 view from technical room

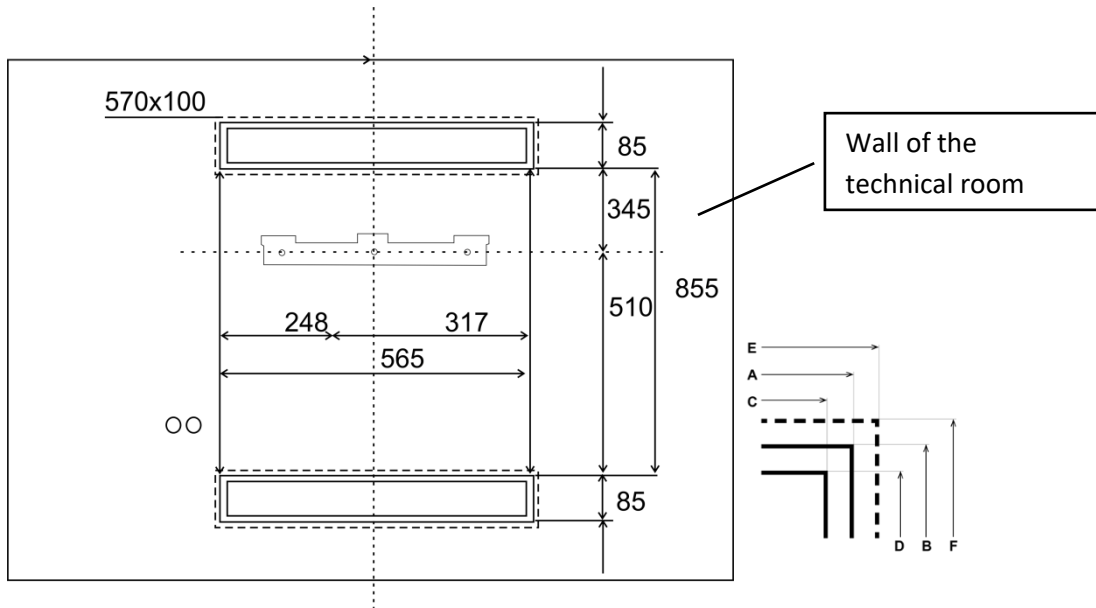

A – construction opening width = 565 mm
C – pipe width = 545 mm
E – grill width = 570 mm

B – construction opening height = 85 mm
D – pipe height = 65 mm
F – grill height = 100 mm

DRY 500 view from technical room

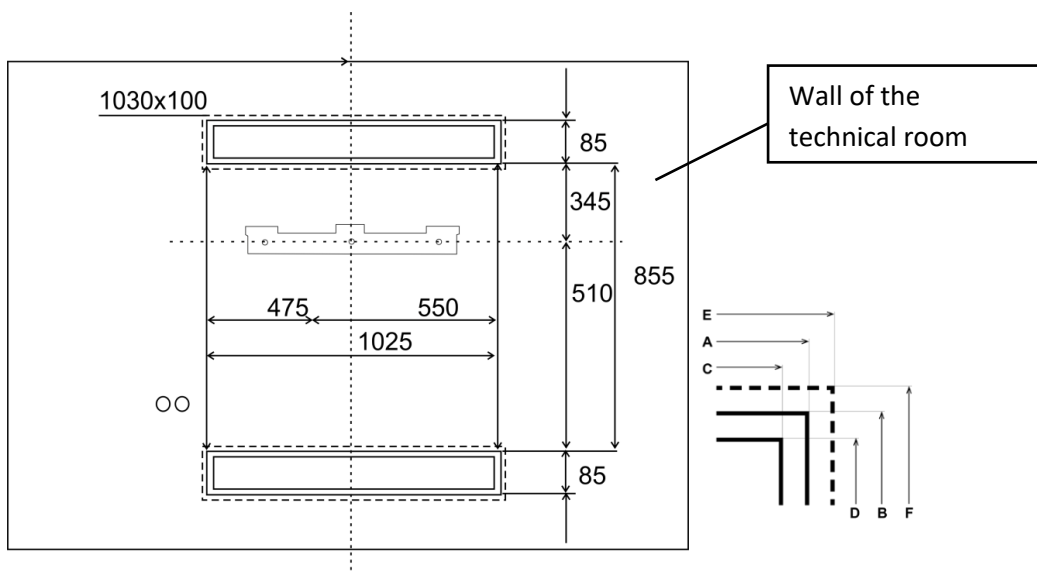

A – construction opening width = 1025 mm
C – pipe width = 1005 mm
E – grill width = 1030 mm

B – construction opening height = 85 mm
D – pipe height = 65 mm
F – grill height = 100 mm

DRY 300 / 400 / 500 – cut view

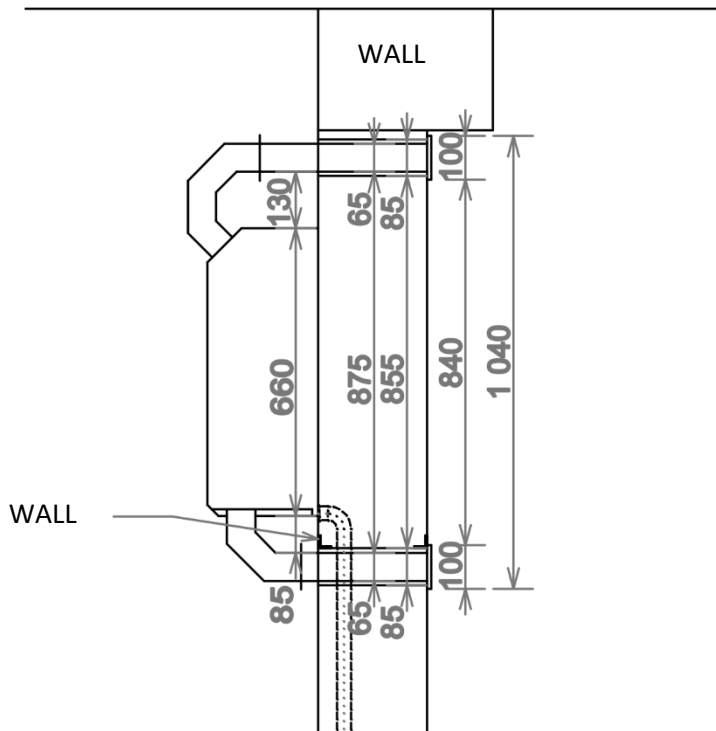

Proper installation of grilles

When fitting the grilles, pay attention to the inclination of the slats and fit the grilles as shown below.

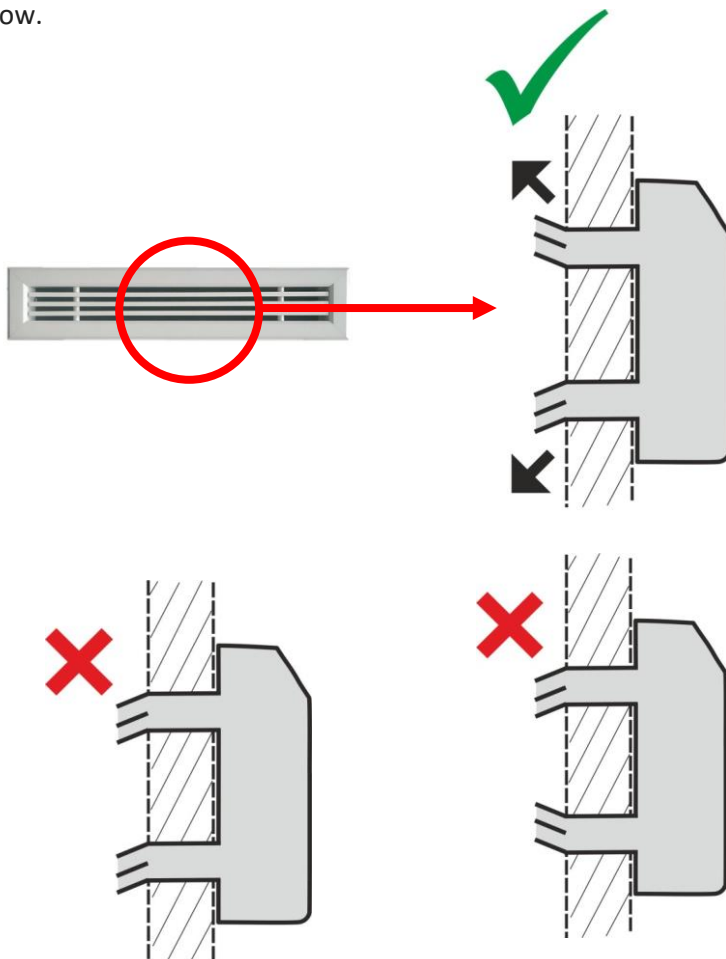

A. PREMIUM through the wall installation with METAL COVER



DRY 300 TTW-E and DRY 400 TTW-E



DRY 500 TTW-E

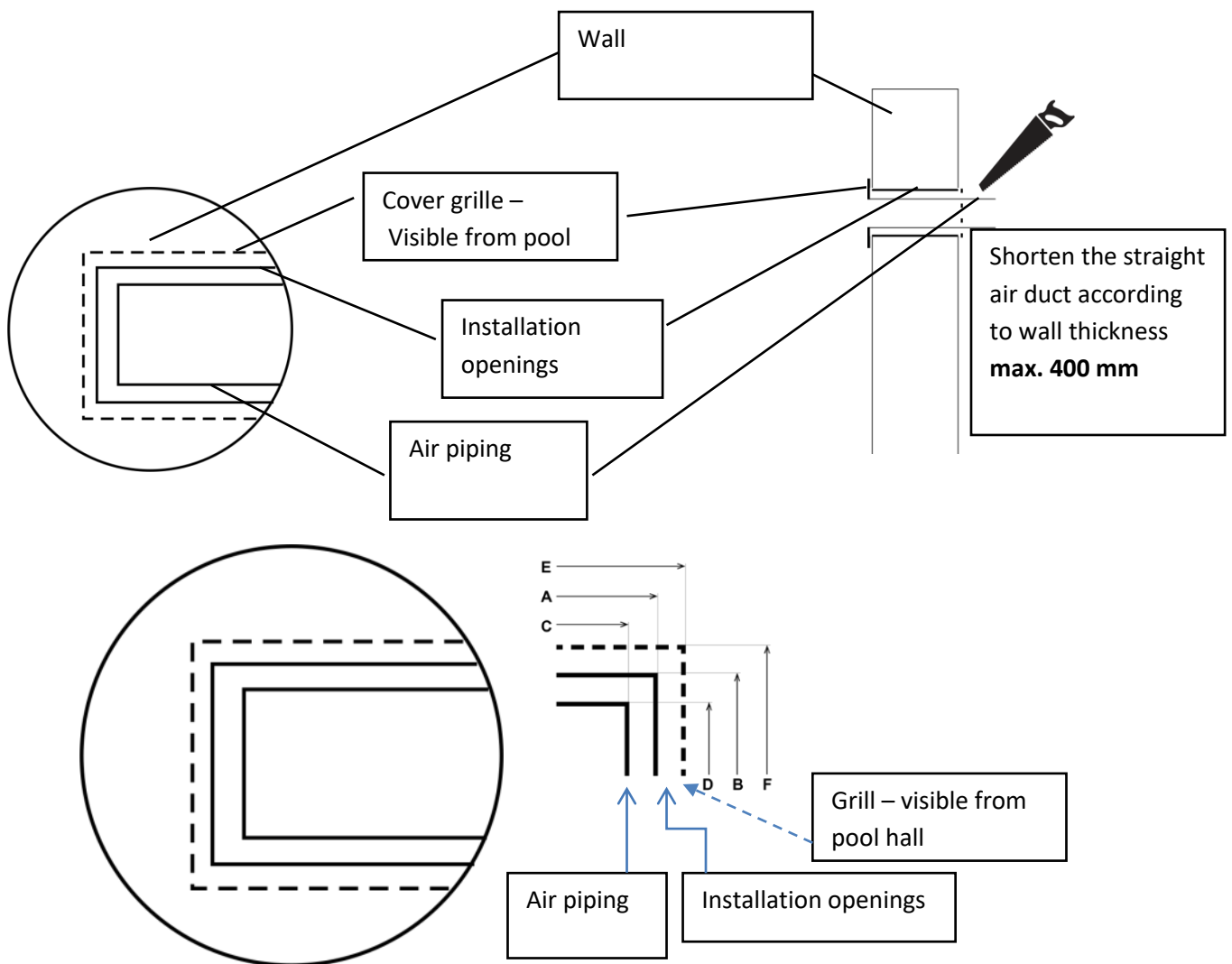

DRY300-400		WIDTH	HEIGHT
Installation openings in wall	A, B	565mm	85mm
Air piping	C, D	545mm	65mm
Grill	E, F	570mm	100mm

DRY500		WIDTH	HEIGHT
Installation openings in wall	A, B	1025mm	85mm
Air piping	C, D	1005mm	65mm
Grill	E, F	1030mm	100mm

**View from technical room (where the dehumidifier is hung on the wall)–
DRY300/400**

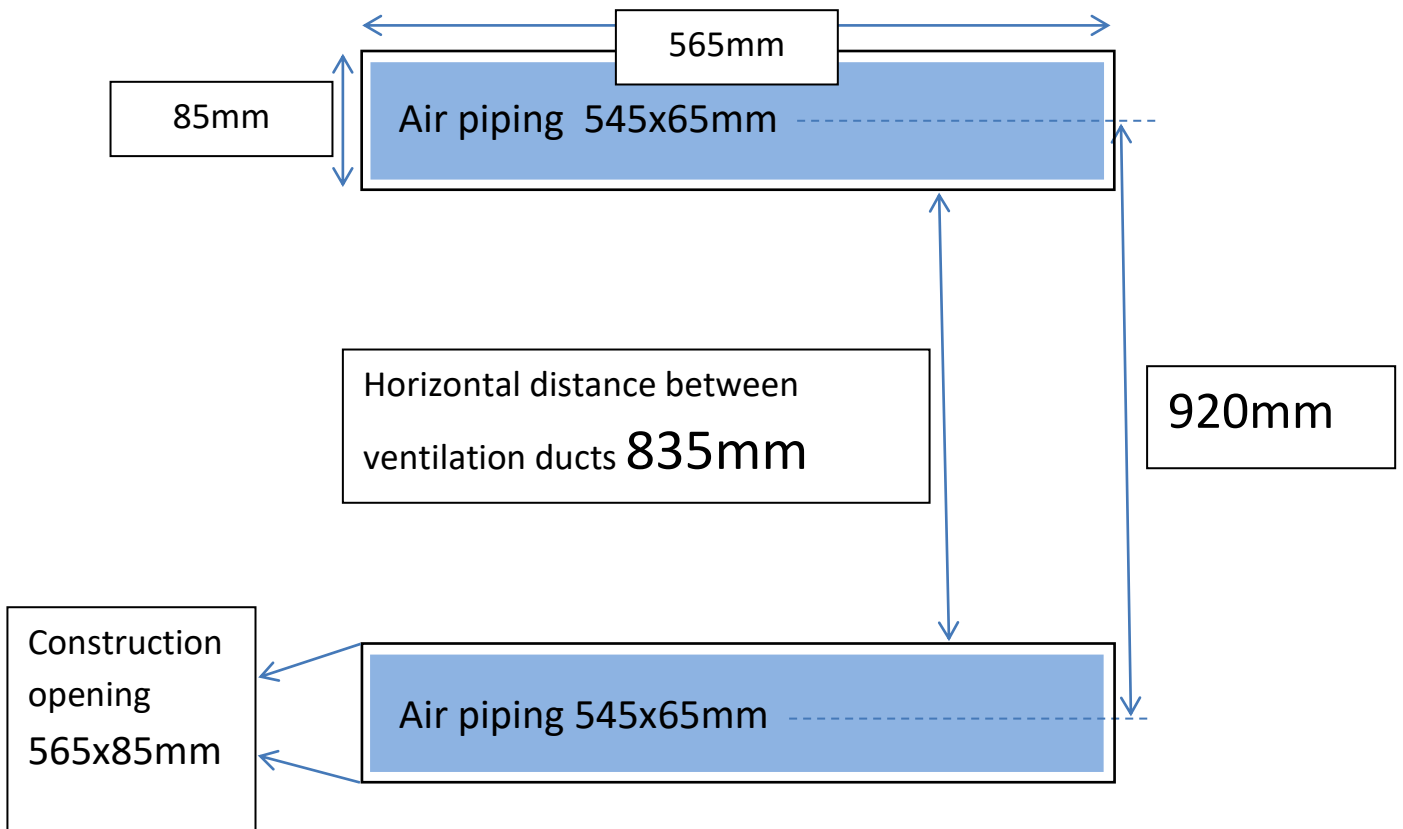

Please keep a distance of 5mm.

**View from technical room (where the dehumidifier is hung on the wall)–
DRY300/400**

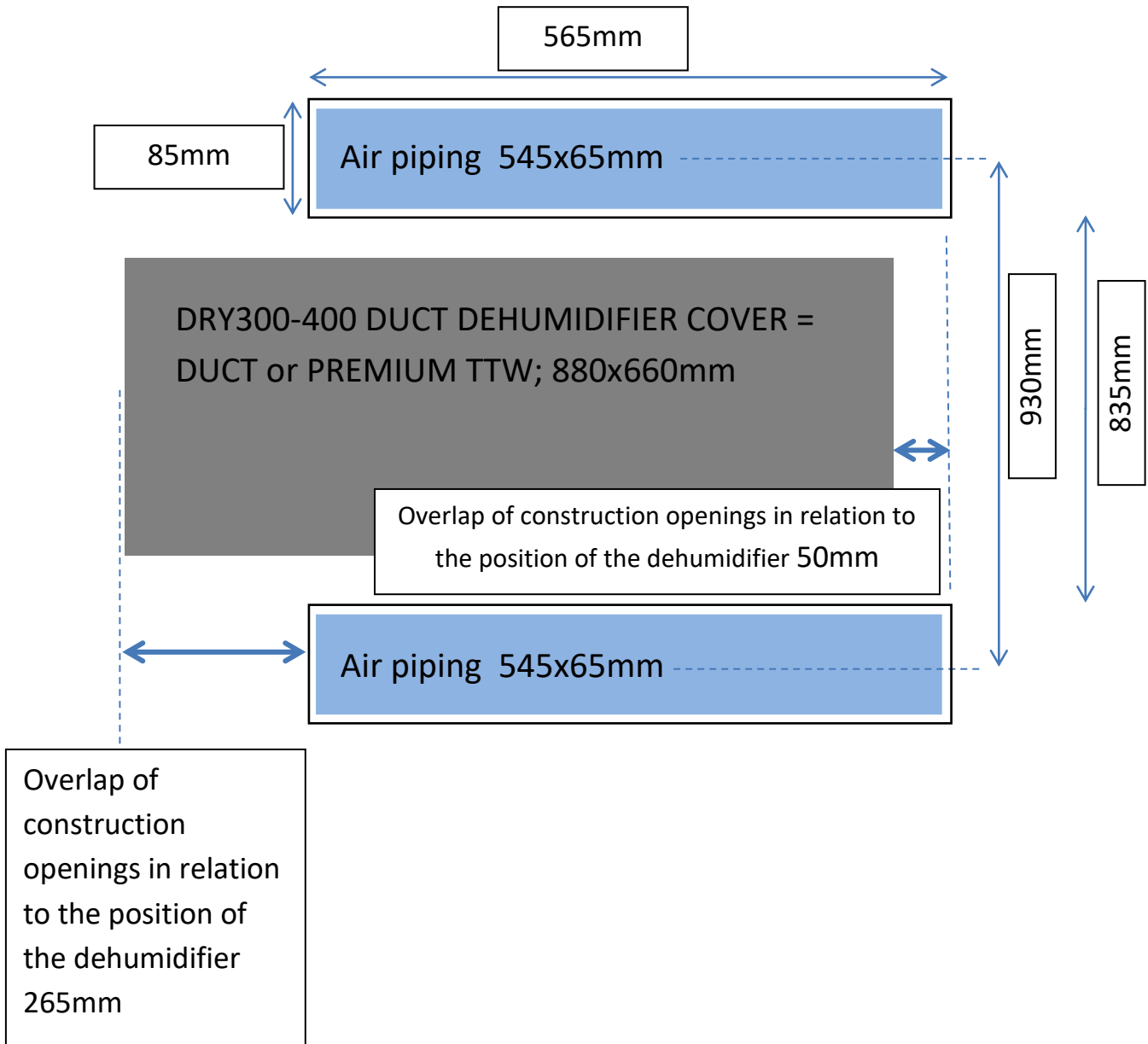

Please keep a distance of 5mm.

View from technical room (where the dehumidifier is hung on the wall) – DRY500

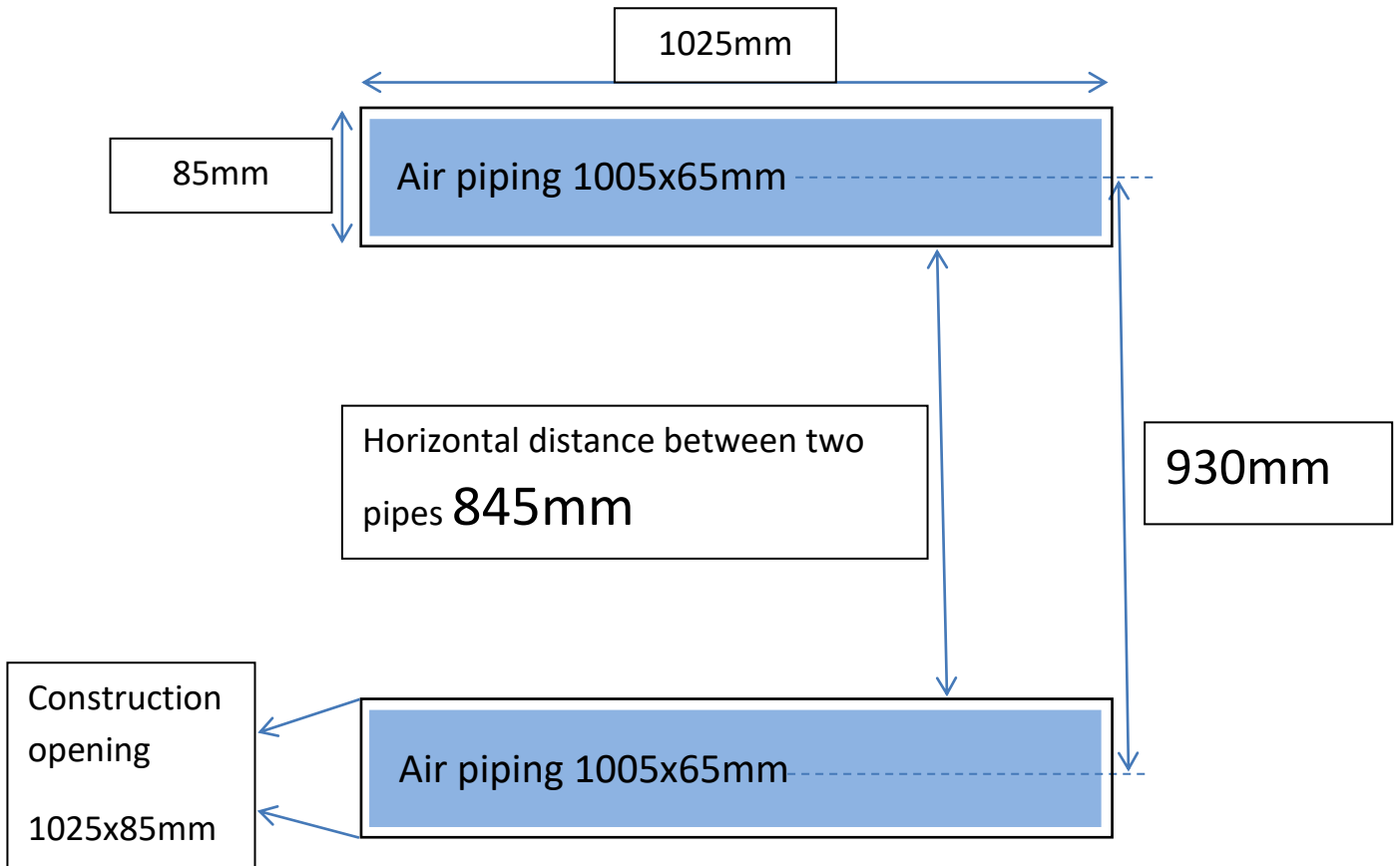

Please keep a distance of 5mm.

View from technical room (where the dehumidifier is hung on the wall) – DRY500

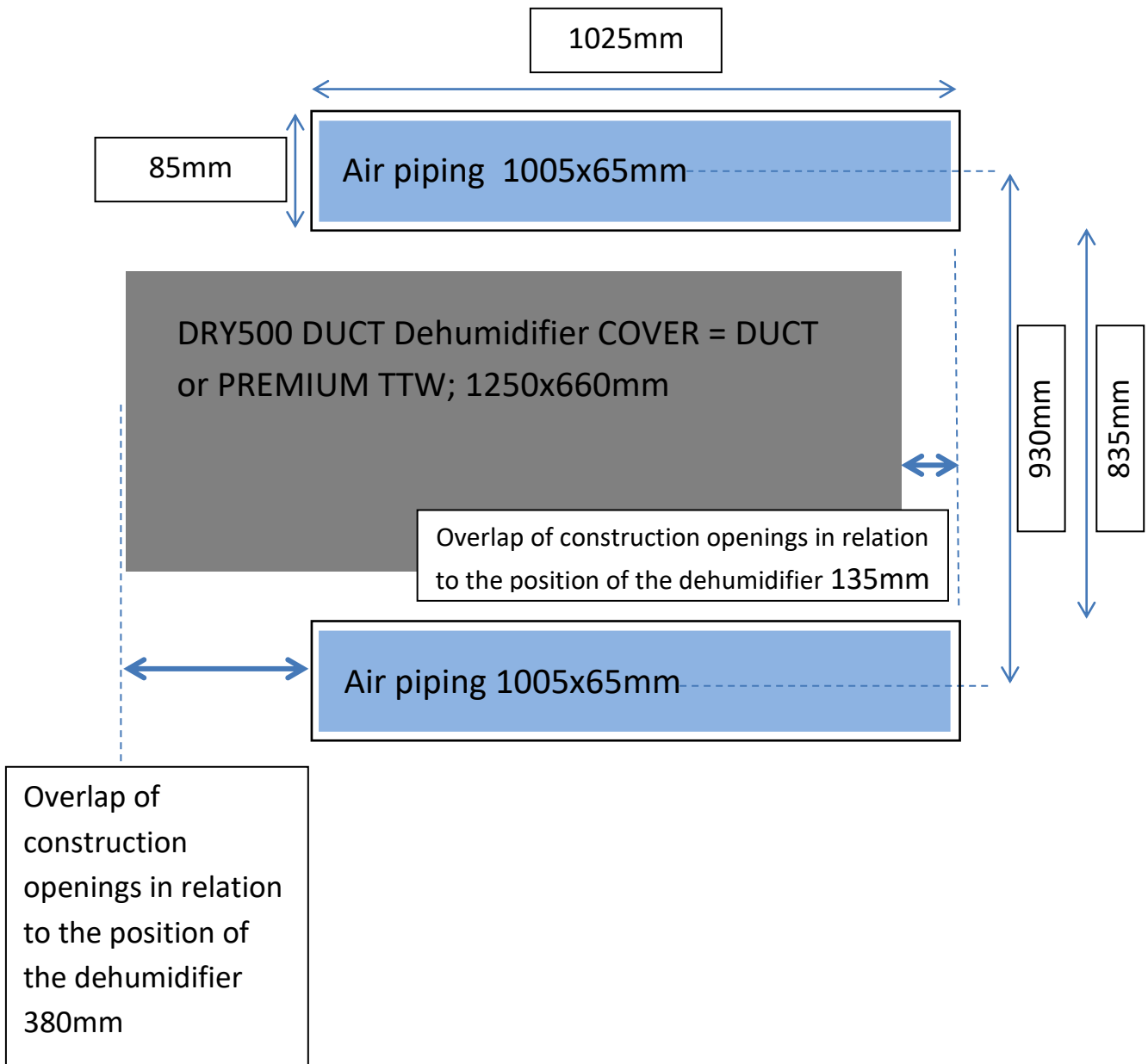

Please keep a distance of 5mm.

External mounting

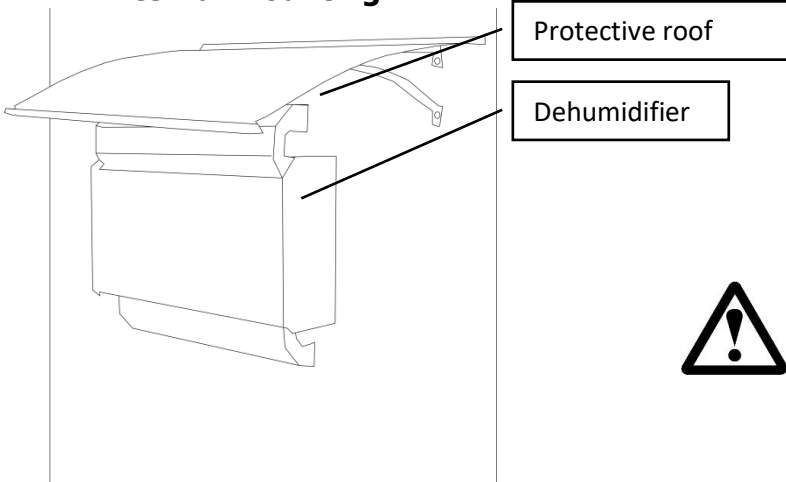

The Microwell dehumidifier can also be installed outdoors. This design must be specified when ordering the device. The dehumidifier will be equipped with a special thermal insulation that's up to 40 mm thick with an aluminum surface, defrosting of the condensing tray and heating of the compressor. Such a device is designed to operate at temperatures down to -15 °C.



In the case of external installation, it is necessary to install a protective roof over the dehumidifier to protect it against rain and snow.

Steps for adjusting a straight air duct through a wall to the size of the wall

1. Separate the flange from the air duct

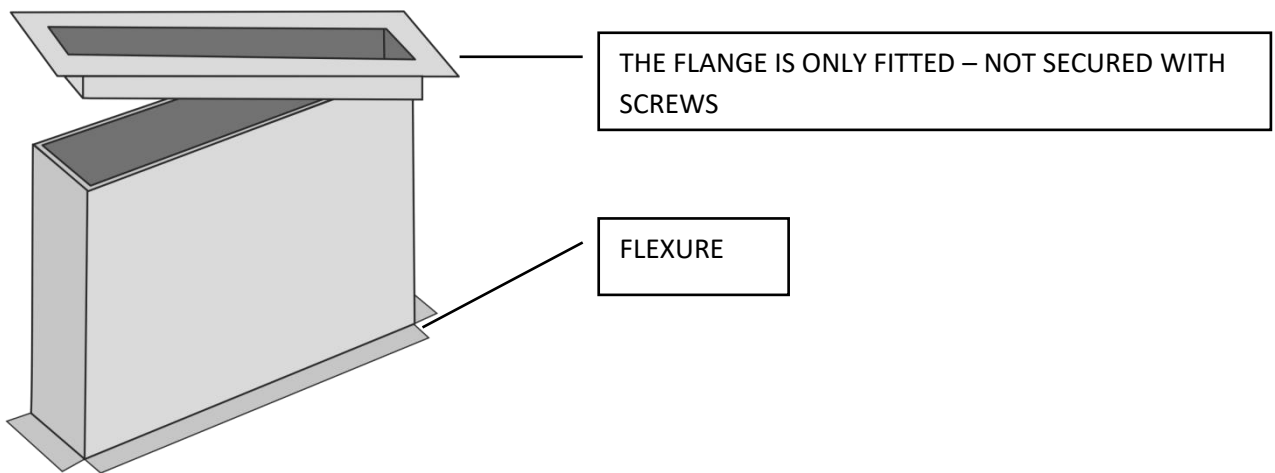

2. Shorten the air duct to fit the wall, as needed

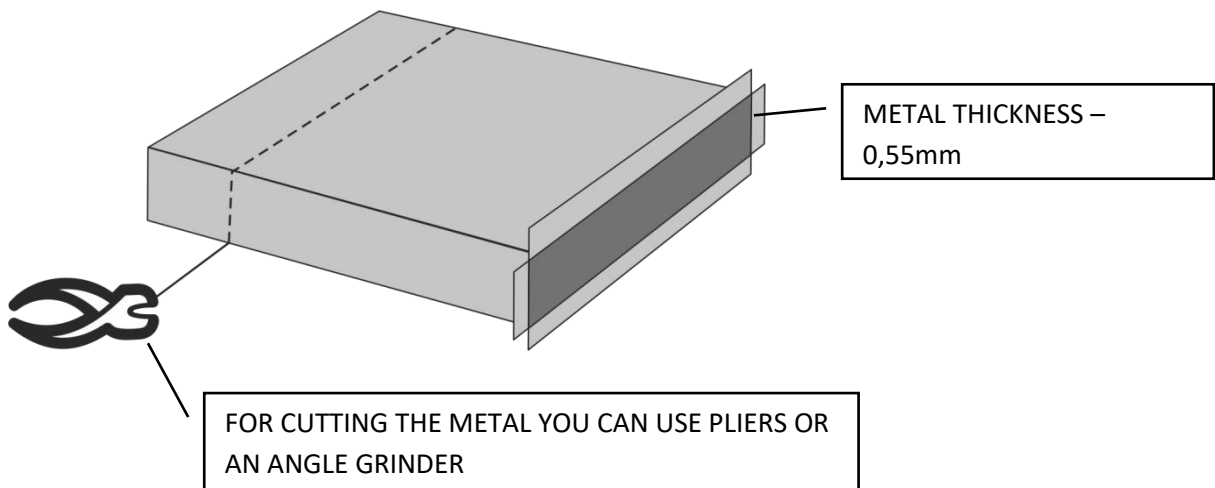

3. Slide in the flange and tighten with four self-tapping screws

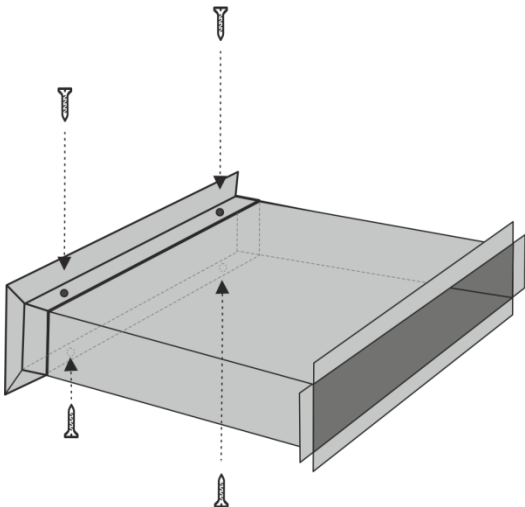

4. Slide in the flange and tighten with four self-tapping screws

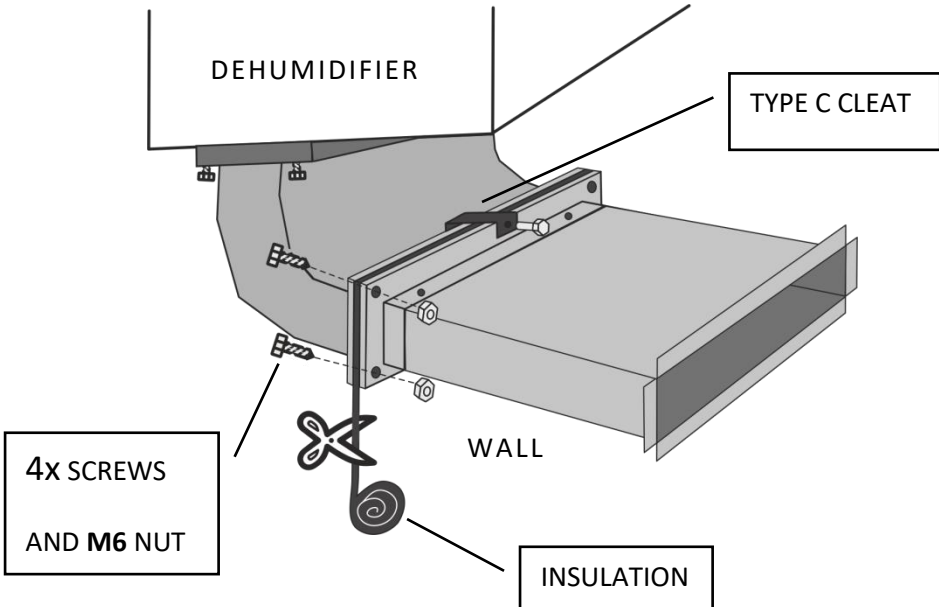

Through the wall installation steps (TTW)



1. Cutting wall transitions



2. Console measuring using template



3. Wall console assembly



4. Installation of dehumidifier and connection of electric cable and condensate drain



5. Dehumidifier cover assembly



6. Shortening pipe according to wall thickness - cut from the flange side



7. Riveting the flange to the shortened pipe 8. Gluing the seal to the pipe joints



9. Pipe mounting onto the cover 10. Installation of piping with final pool hall wall surface



11. Sealing gaps in wall with PUR foam 12. Assembly of grills



Please note that the PREMIUM installation through the wall differs due to knees.

B. External through the wall-installation

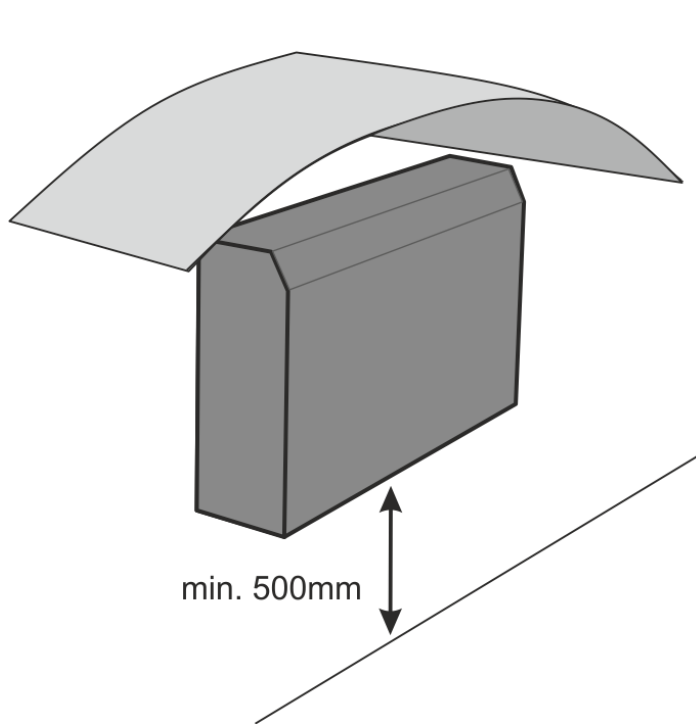

Keep a min. 500 mm vertical distance from the ground (ground, sidewalk, ...) to allow free drainage of condensate and to prevent immersion in snow or puddles.

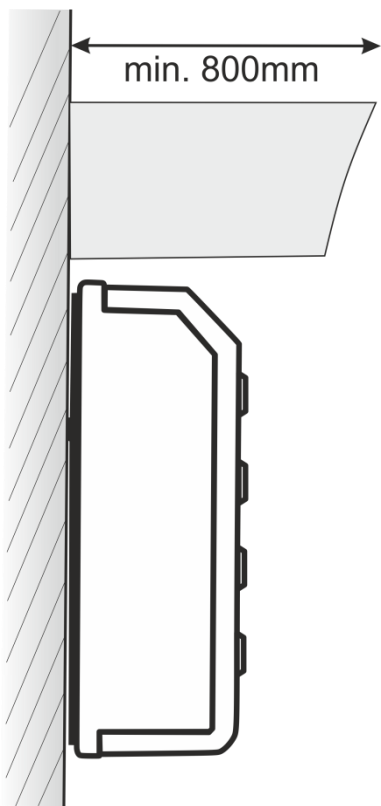

Make a roof over the unit to protect from rain, snow and direct sunlight. Min. 800 mm wide and long + 250 mm on each side.

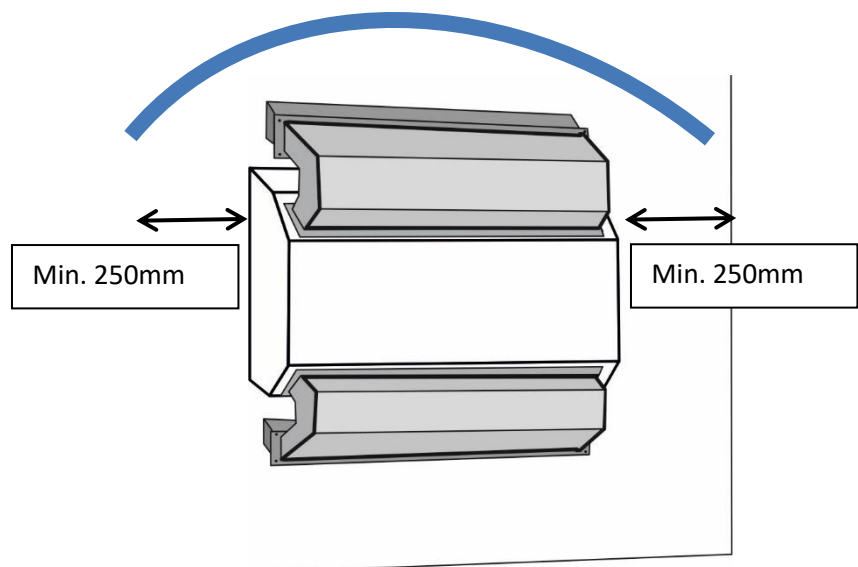

C. Electrical installation FRESH AIR INTAKE WITH AUTOMATIC CONTROL OF

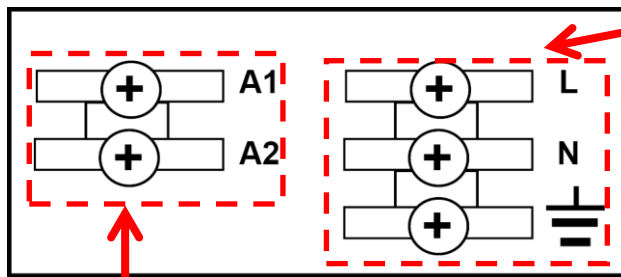
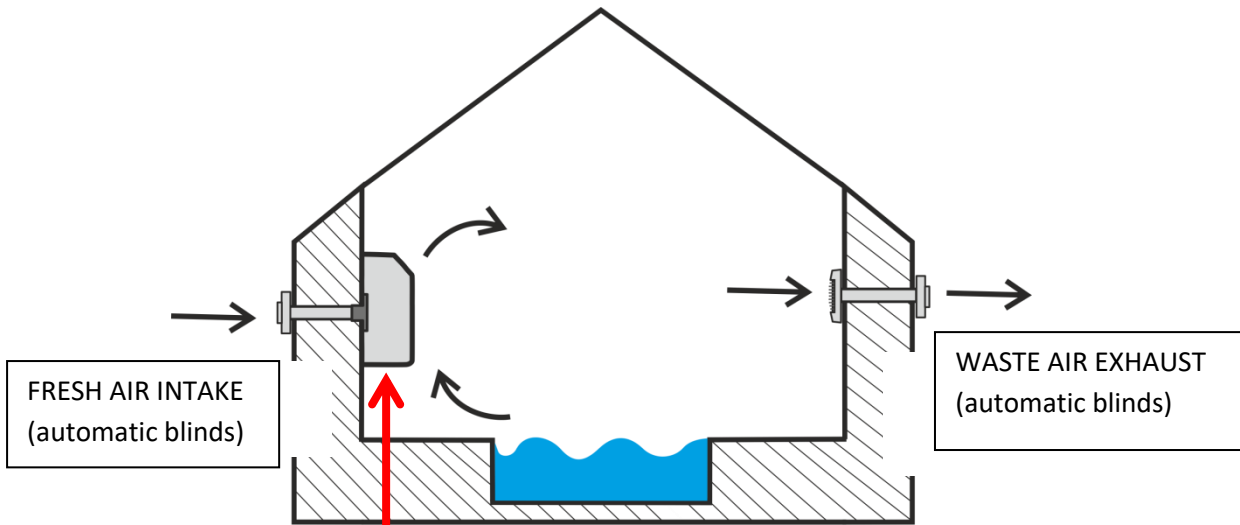

MAIN POWER SUPPLY OF DEHUMIDIFIER
230V/50Hz/1f
3x 2.5mm² CYSY
breaker 16A type C
circuit breaker 30mA

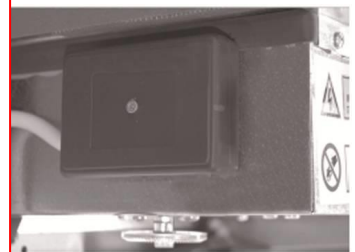

PERIPHERAL CONTROL
230V/50Hz/1f
3x 0.5-1mm² CYSY
Separate contactor with separate phase

The contactor is supplied by the customer (fan and electric blinds are part of the delivery if ordered)

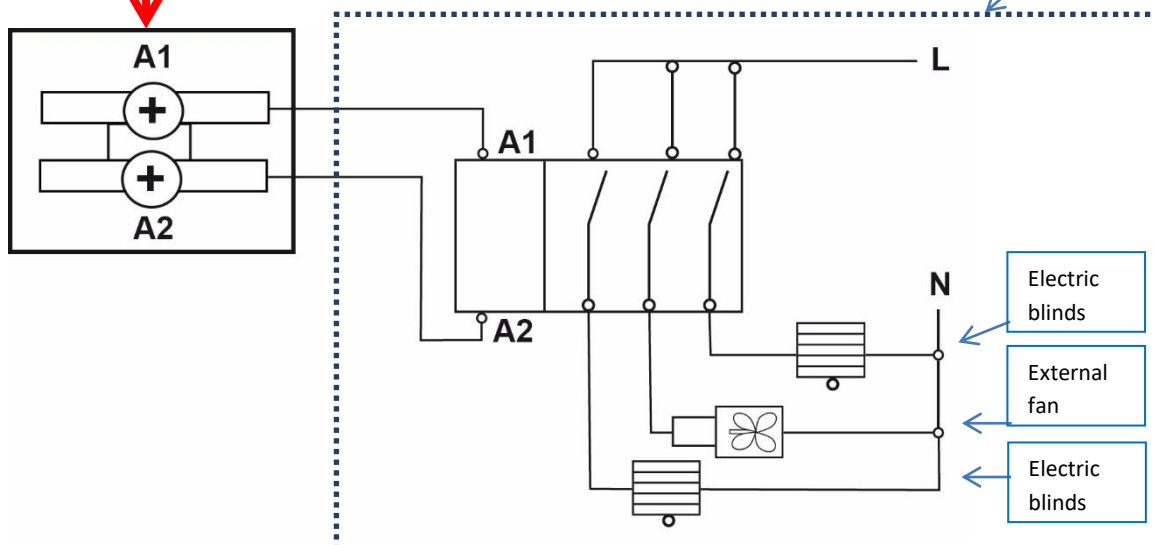

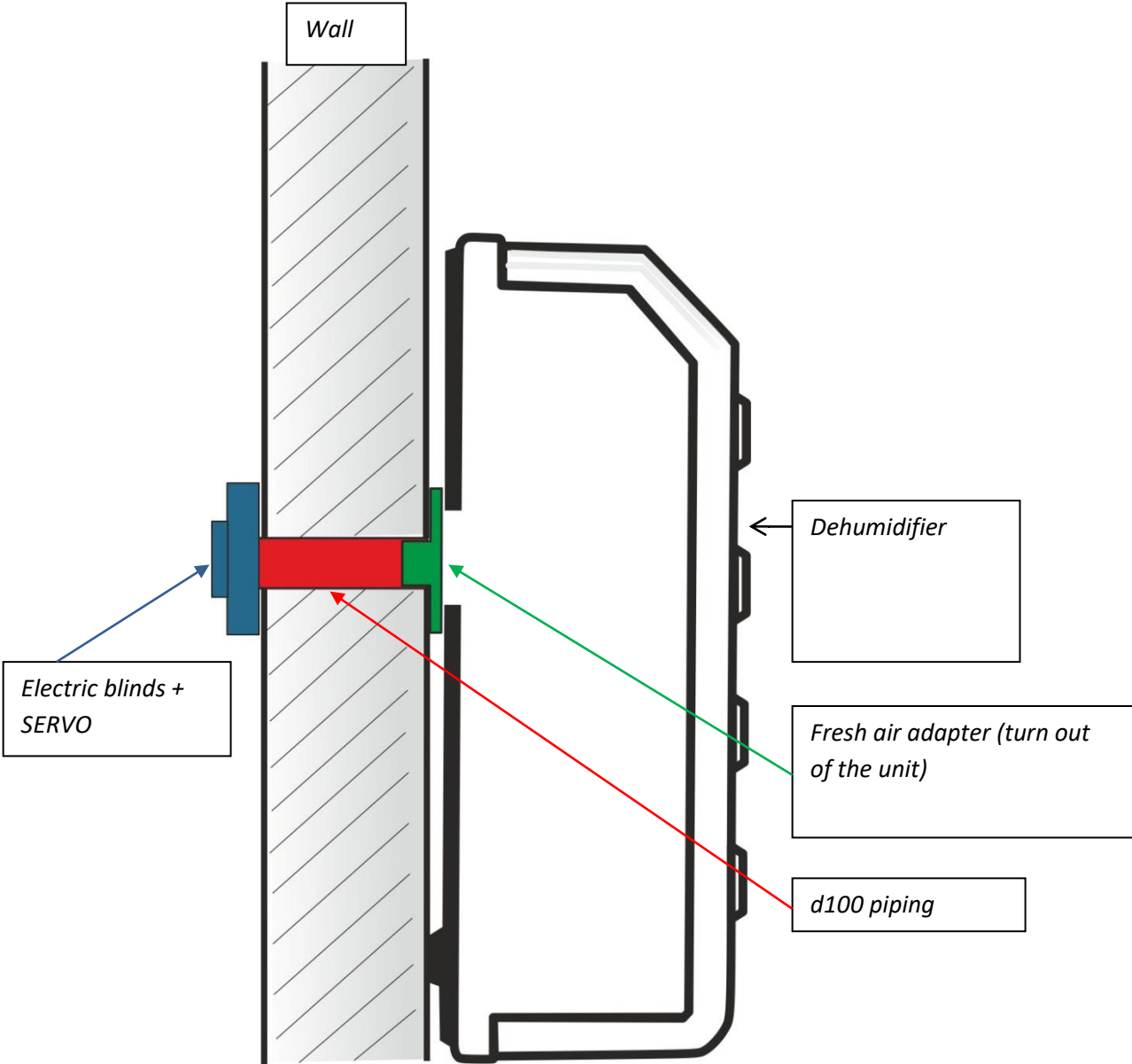

6 TECHNICAL DATA

6.1 Technical data chart*

Data	Unit	DRY 300 WAVE	DRY 400 WAVE	DRY 500 WAVE
For swimming pool with a max. water surface of:	m ²	30	45	60
Dehumidification performance at 30°C and 60% RH	l/24h	36	48	66
Dehumidification performance at 30°C and 70% RH	l/24h	43	53	83
Dehumidification performance at 30°C and 80% RH	l/24h	48	58	101
Standard operating temperature	°C	22-35	22-42	22-35
Operating temperature - defrost set	°C	15-35	15-42	15-35
Operating temperature - Thermostatic expansion valve (TEV)	°C	22-42	-	22-42
Operating temperature - defrost set + TEV	°C	15-42	-	15-42
Operating temperature - reverse defrost	°C	5-35	-	5-35
Operating humidity range	% RH	20-100	20-100	20-100
Water flow	m ³ /h	550	600	800
Noise (at 1m distance)	dB (A)	42	42	44
Heating output	W	1900	1900	3500
El. input	W	700	700	1000
Power supply	V/Hz/f	230/50/1	230/50/1	230/50/1
Operating/starting current	A	3,1/15	3,1/15	4,5/15
El. insulation – type C	A	10	10	16
Power cord	mm ²	CYSY 3C x 1,5	CYSY 3C x 1,5	CYSY 3C x 2,5
Condensing pipe - outer diameter	mm	d 20	d 20	d 20
Net dimensions (width x height x depth)	mm	780 x 660 x 255	780 x 660 x 255	1245 x 660 x 255
Net weight	kg	40	40	60
Refrigerant quantity - R 410 A	kg	0,55; 1,15t CO ₂ ekv.	0,6; 1,25t CO ₂ ekv.	0,75; 1,57 t CO ₂ ekv.
Max. system pressure HP/LP	bar	28,5/8,5	28,5/8,5	28,5/8,5

* The manufacturer reserves the right to change the data without notice.

The refrigerant circuit is filled with R410A refrigerant, which is a two-component refrigerant (R32 / R125). These components are in accordance with Act No. 286/2009 Coll. in conjunction with Regulation (EC) No 1049/2001 of the European Parliament and of the Council 842/2006 considered as fluorinated greenhouse gases. The installations contain fluorinated greenhouse gases covered by the Kyoto Protocol:

R410A with global warming potential (GWP) 2088: (R-32/125 50/50)

These data are for informational purpose only. The exact amount of refrigerant in the appliance is indicated on the rating plate (located at the back of the appliance in the upper right corner).

6.1.1 ELECTRICAL CONNECTION SCHEME of DRY 300/400 – BASIC CONNECTION of
DRY 300.1

30.9.2021

DRY 300.1 (a)

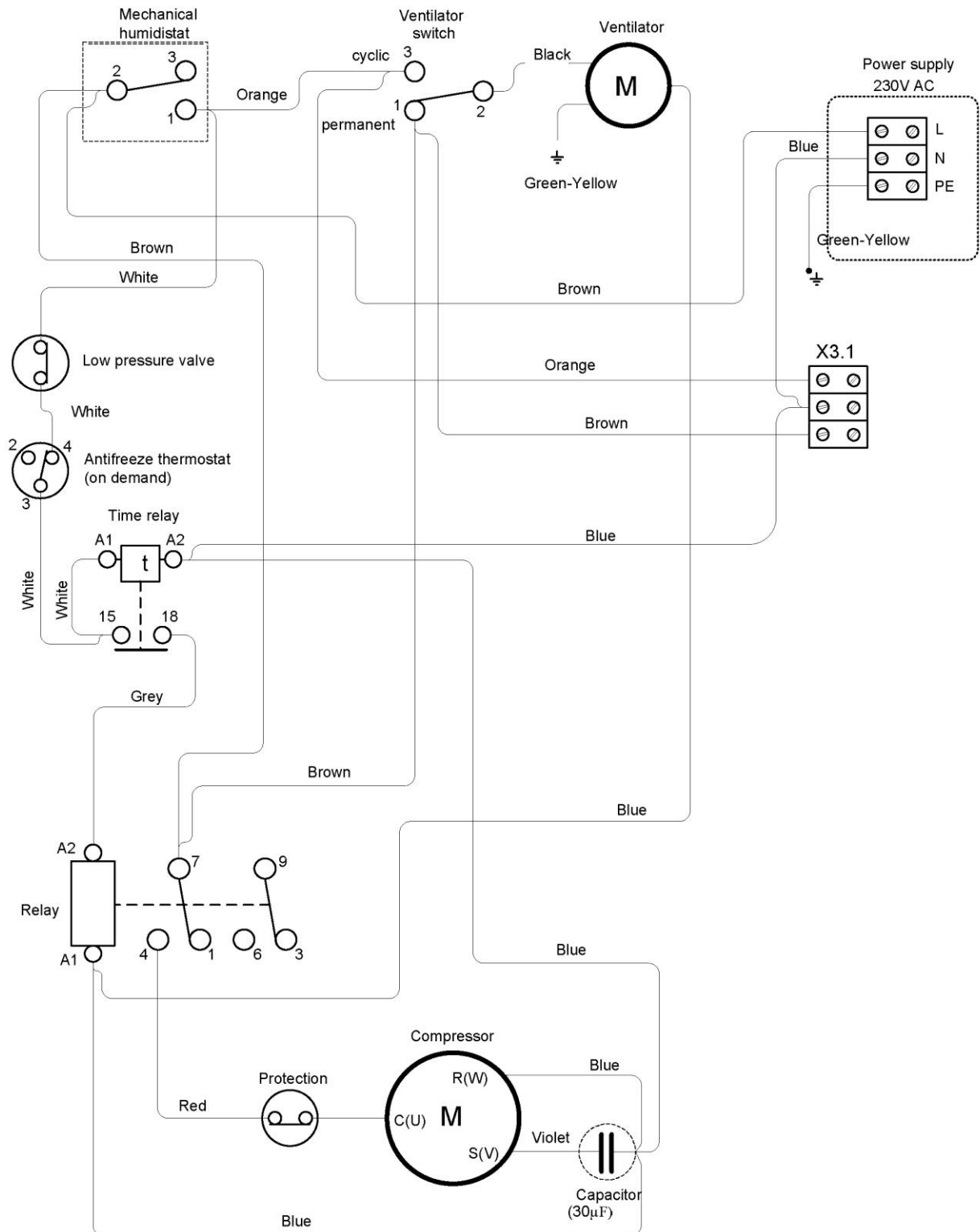

26.01.2021

DRY 300.1 (+EASY 300)

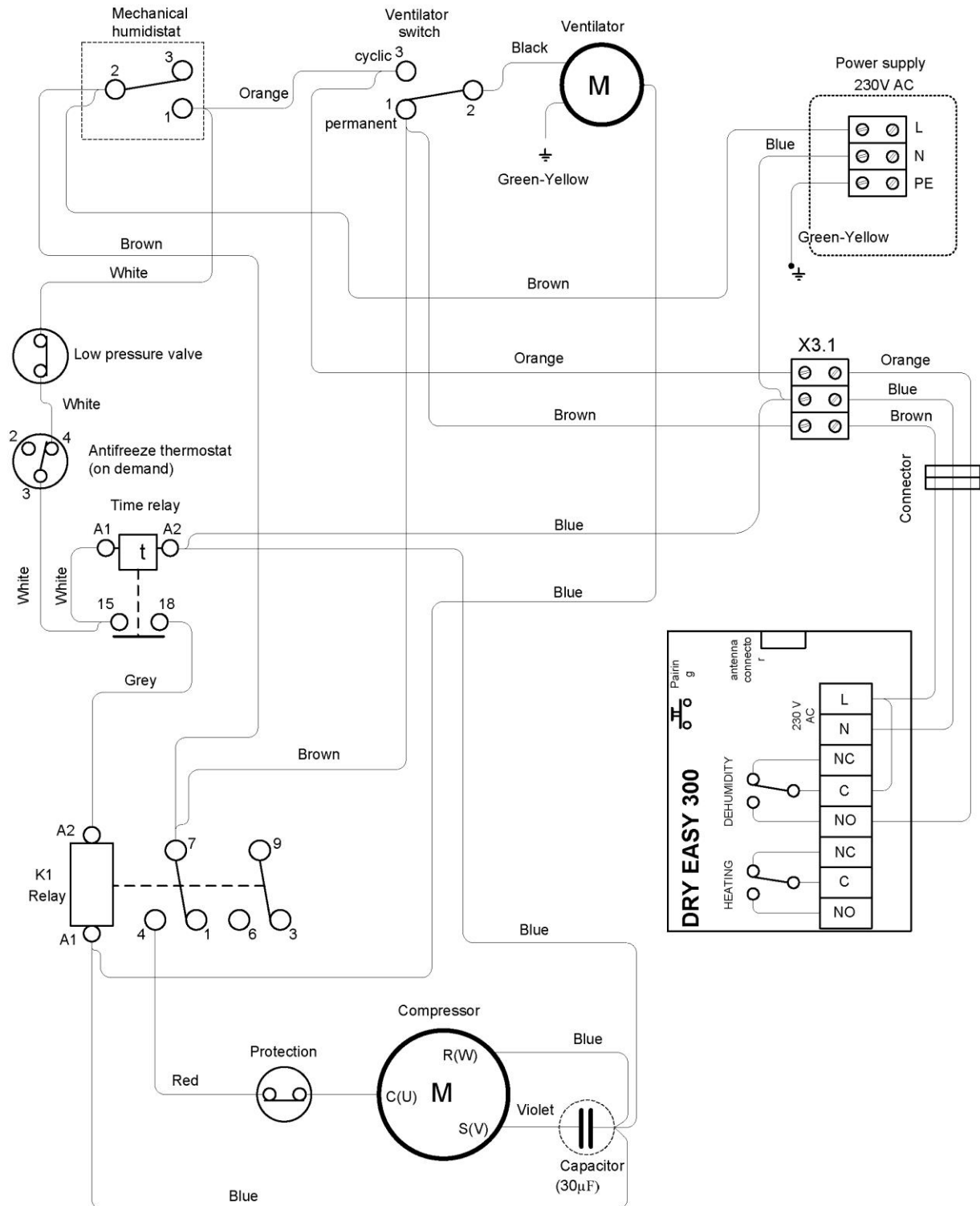

26.01.2021

DRY 300.1 (+EBERLE)

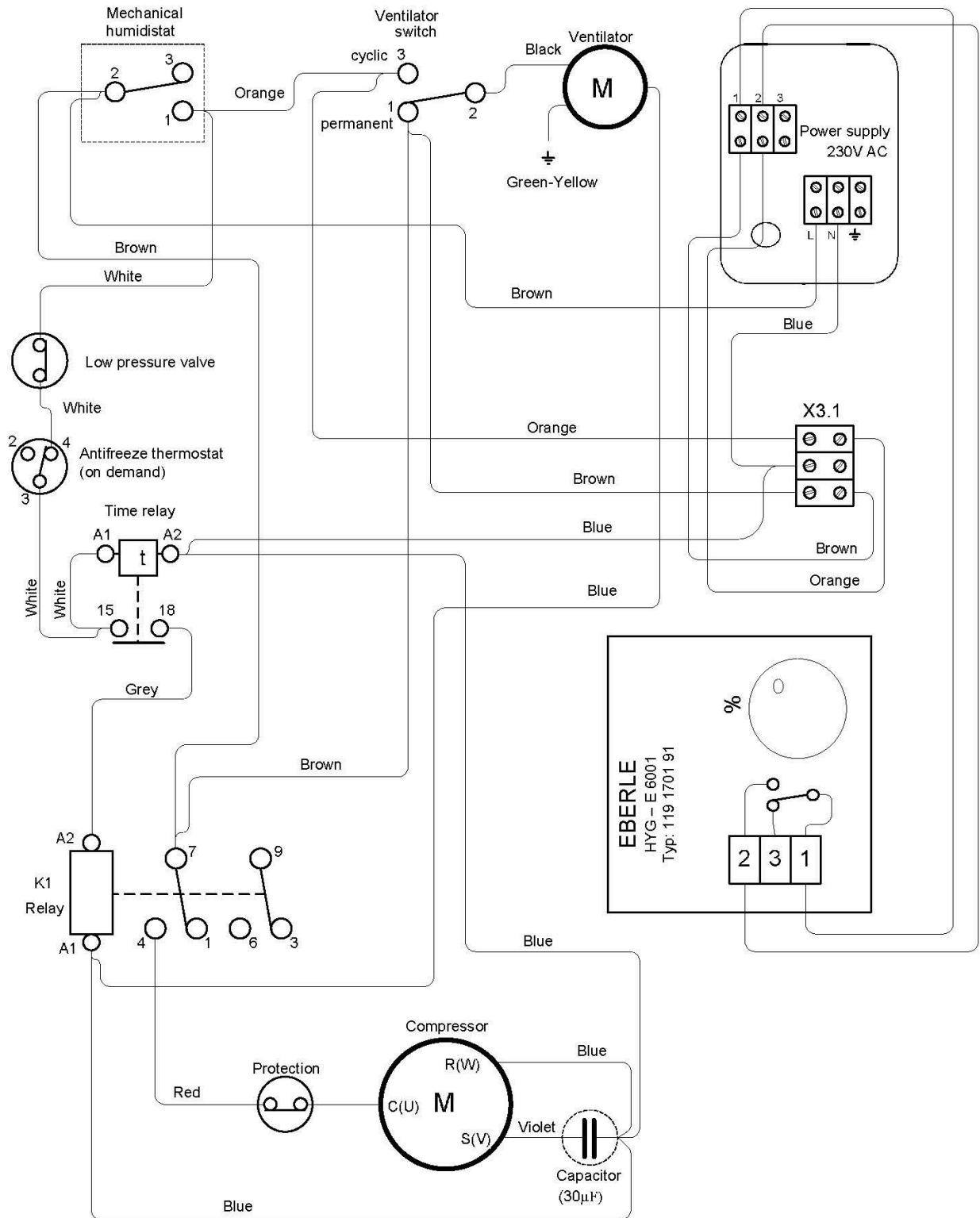

17.3.2017

DRY 300.1_4 way valve (a) 2017

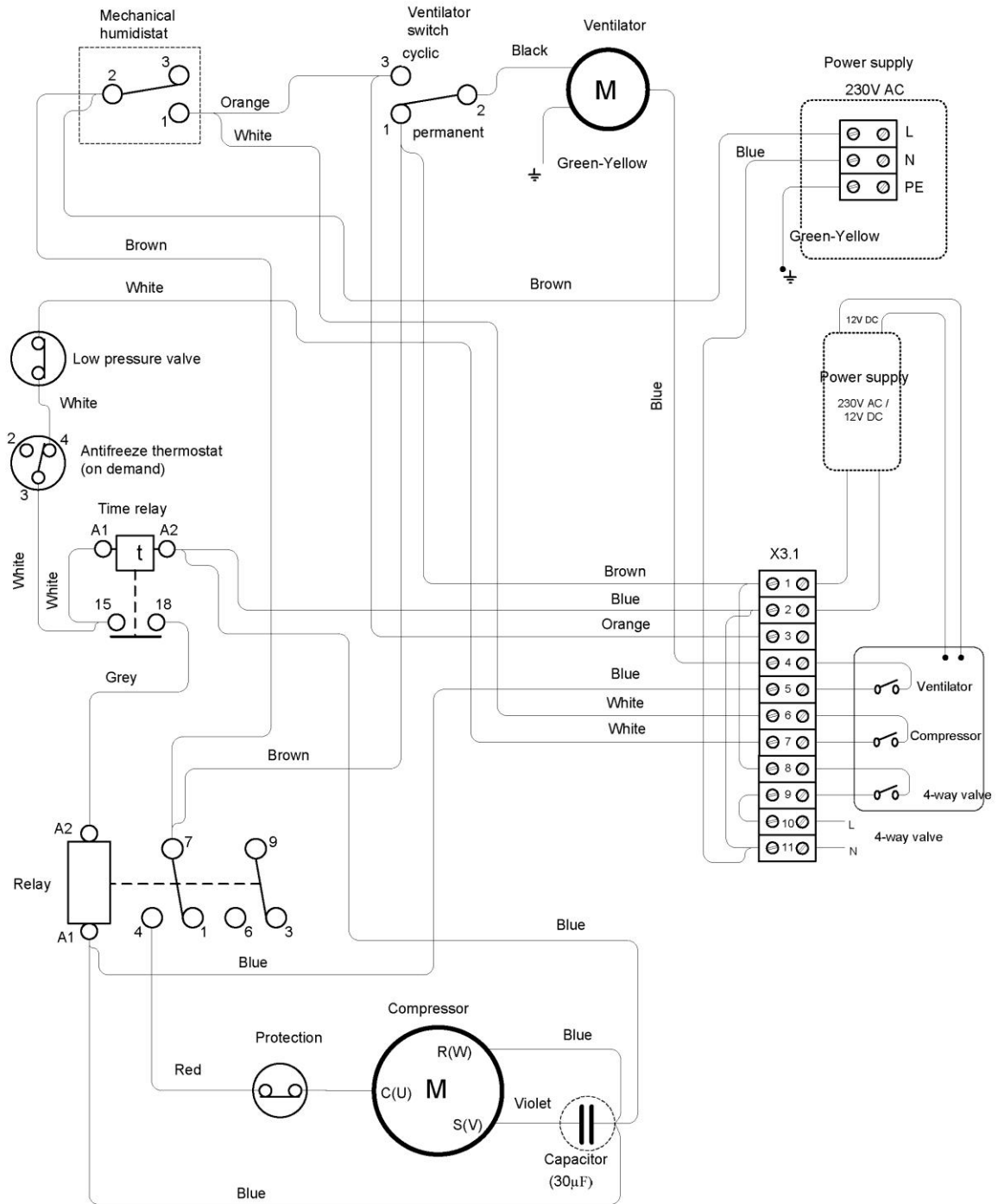

6.1.2 **ELECTRICAL CONNECTION SCHEME of DRY 300/400 – ADVANCED CONNECTION of DRY 300.2**

17.3.2017

DRY 300.2 (b)

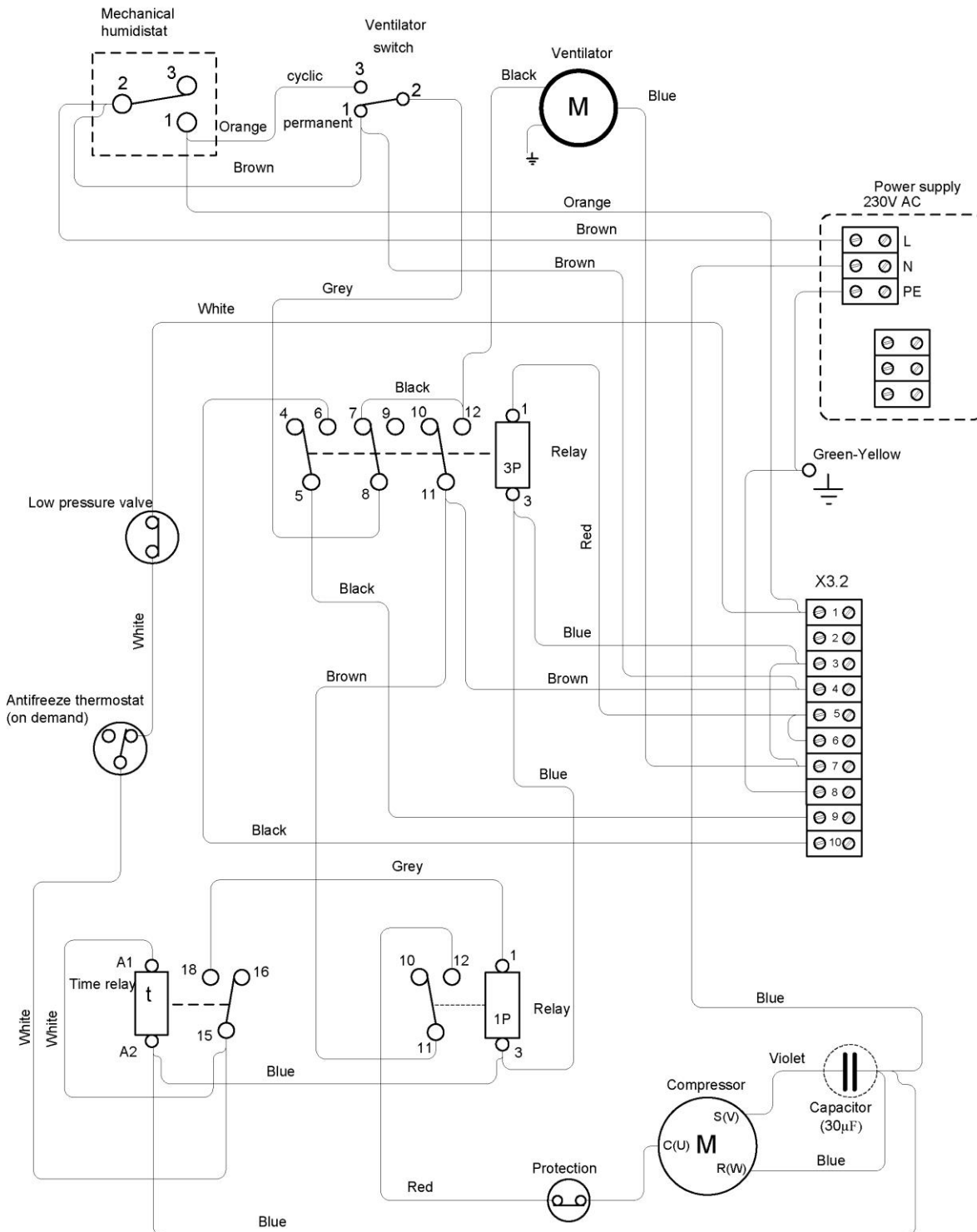

16.5.2019

DRY 300.2 + El. heating 2000W

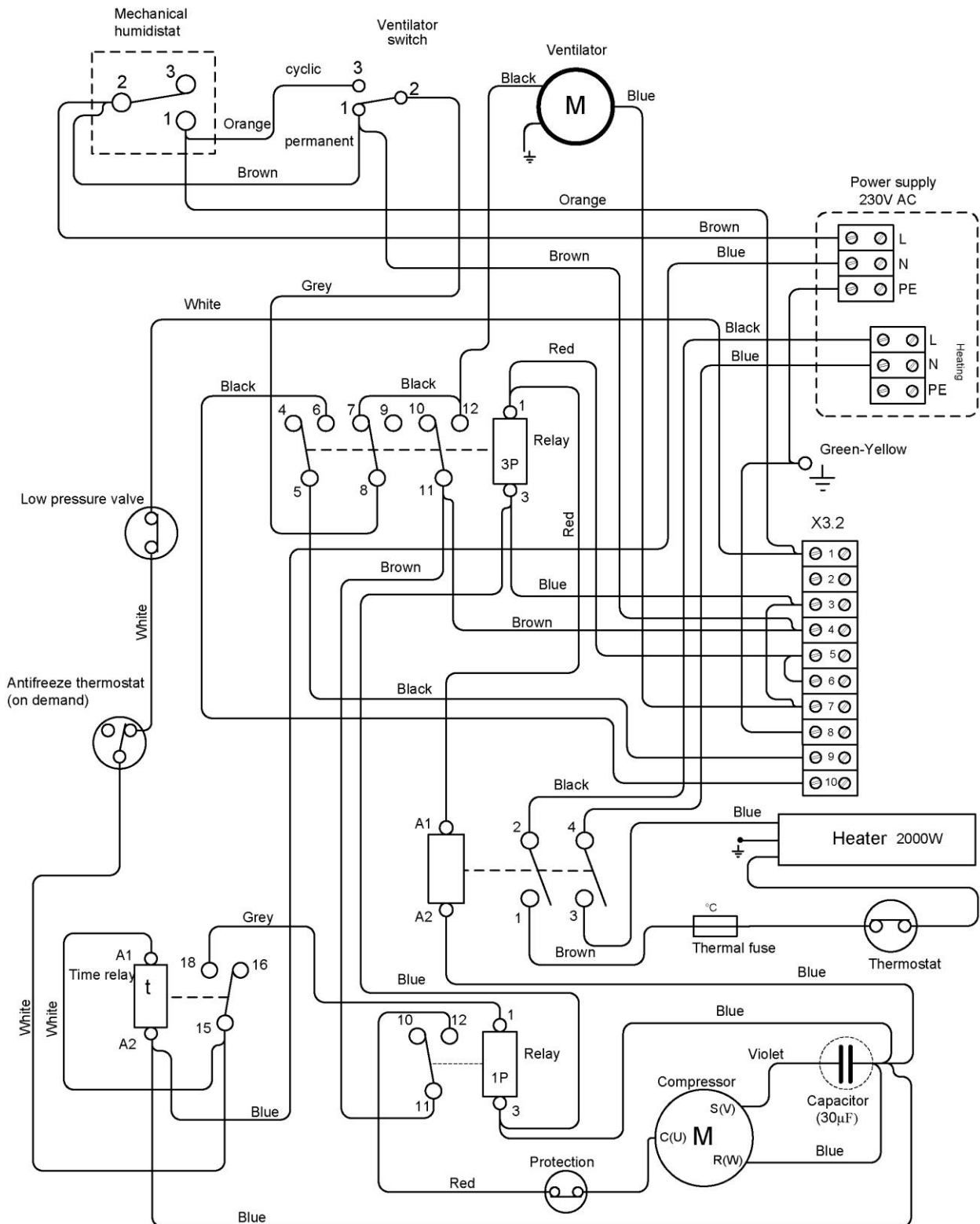

DRY 300.2 / 4- way valve

17.3.2017

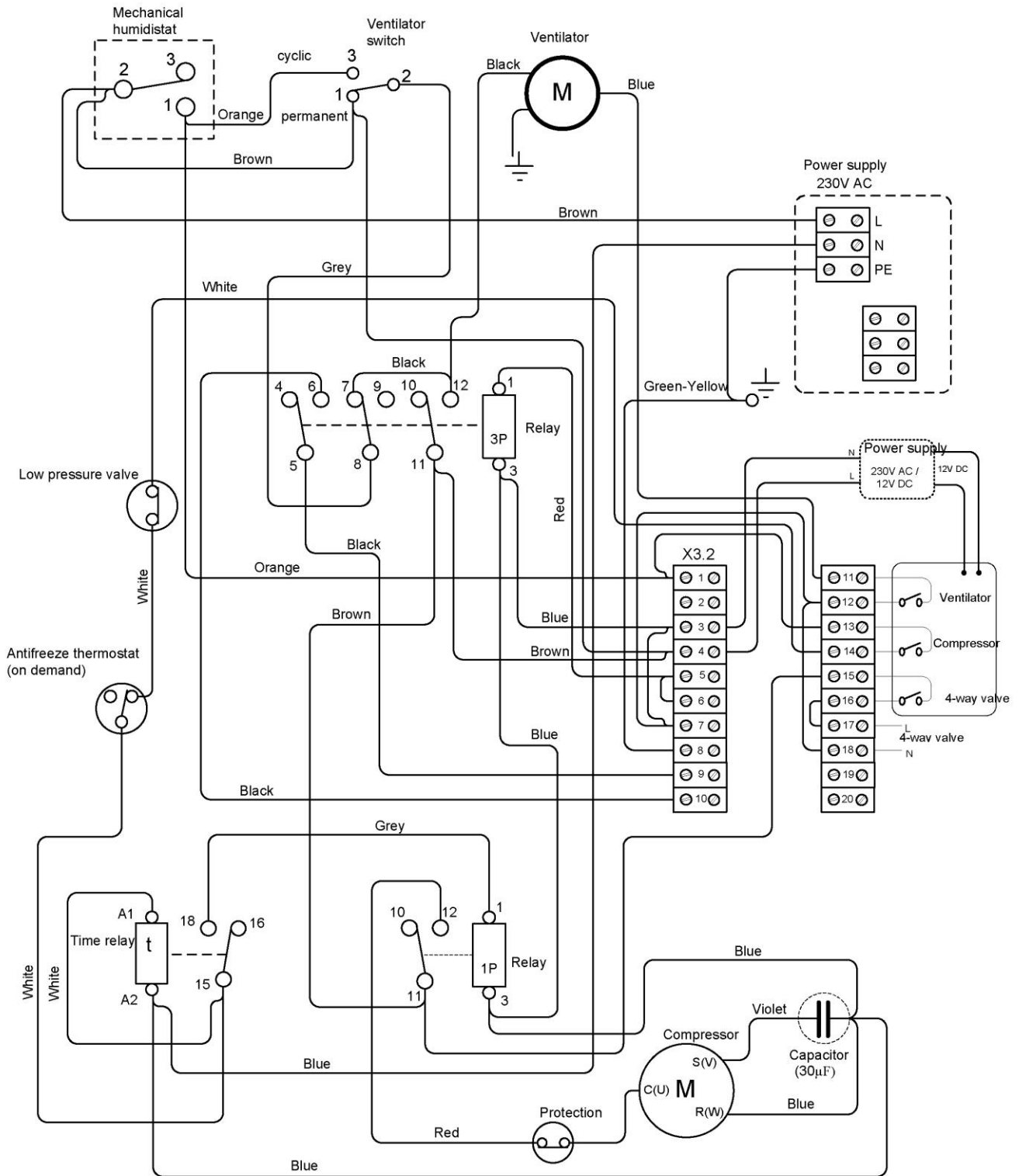

6.1.3 **ELECTRICAL CONNECTION SCHEME of DRY 500 – BASIC CONNECTION**
of DRY 500.1

26.01.2021

DRY 500.1 (2021)

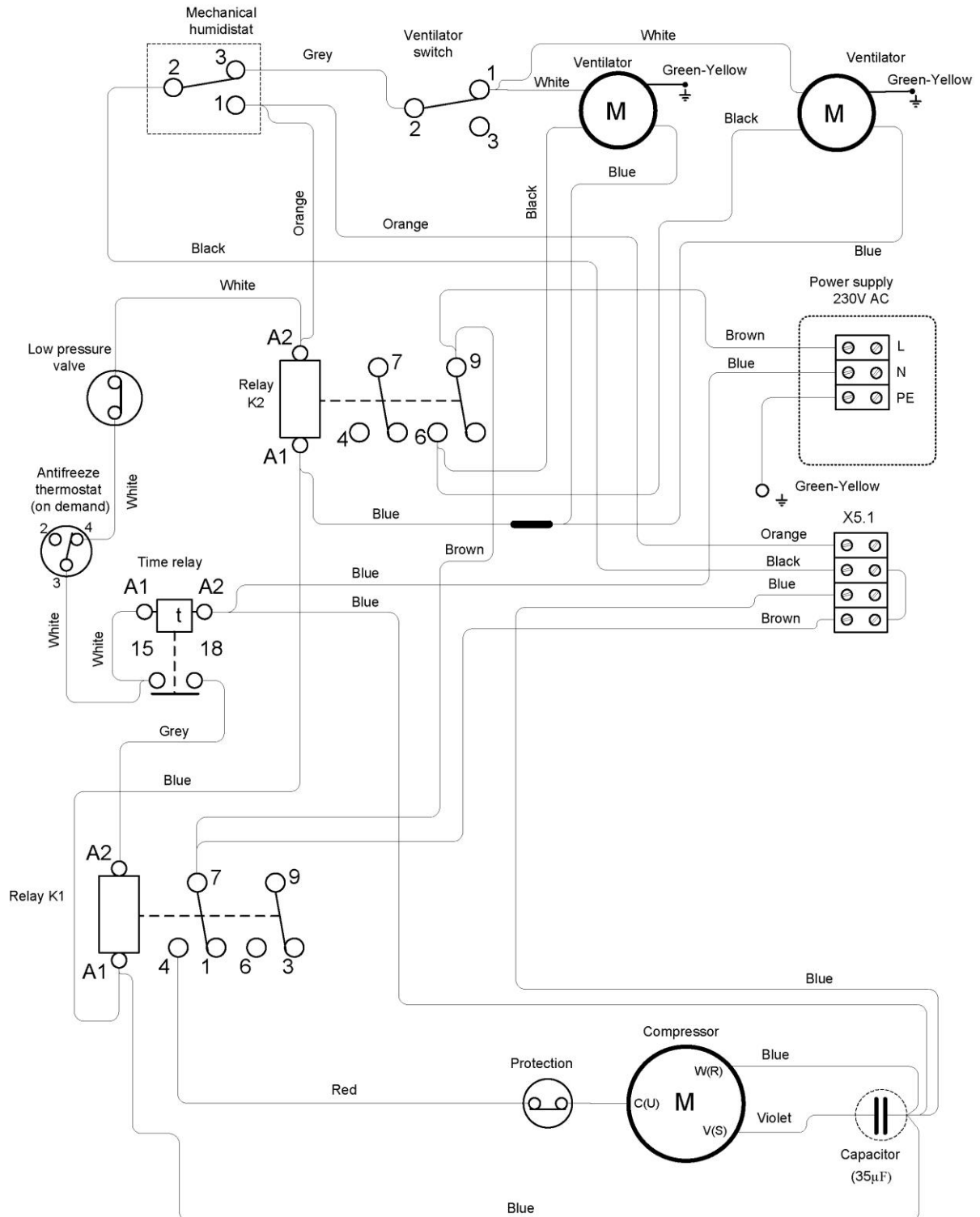

26.01.2021

DRY 500.1 (+ EASY 300) 2021

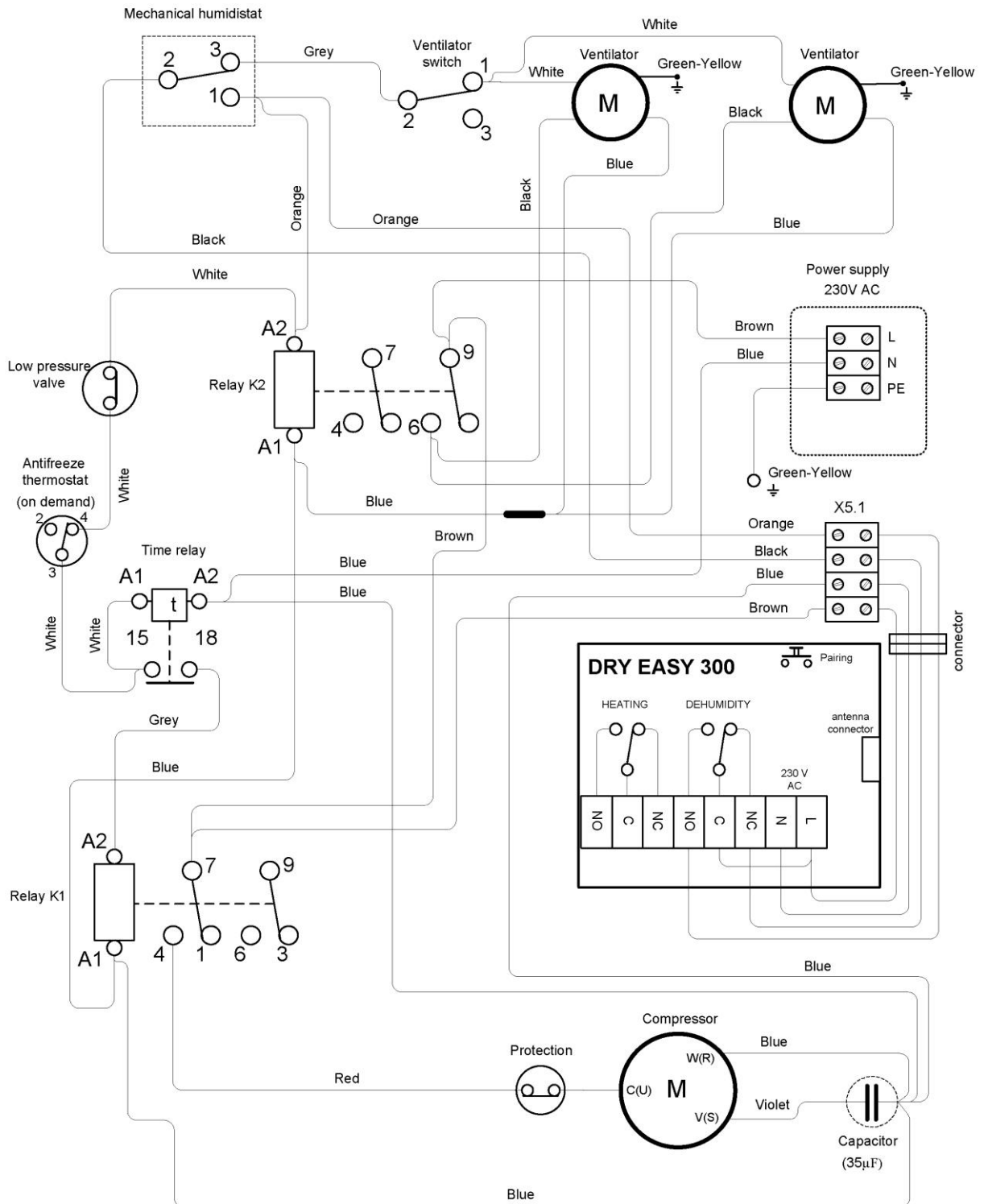

26.01.2021

DRY 500.1 +EBERLE (2021)

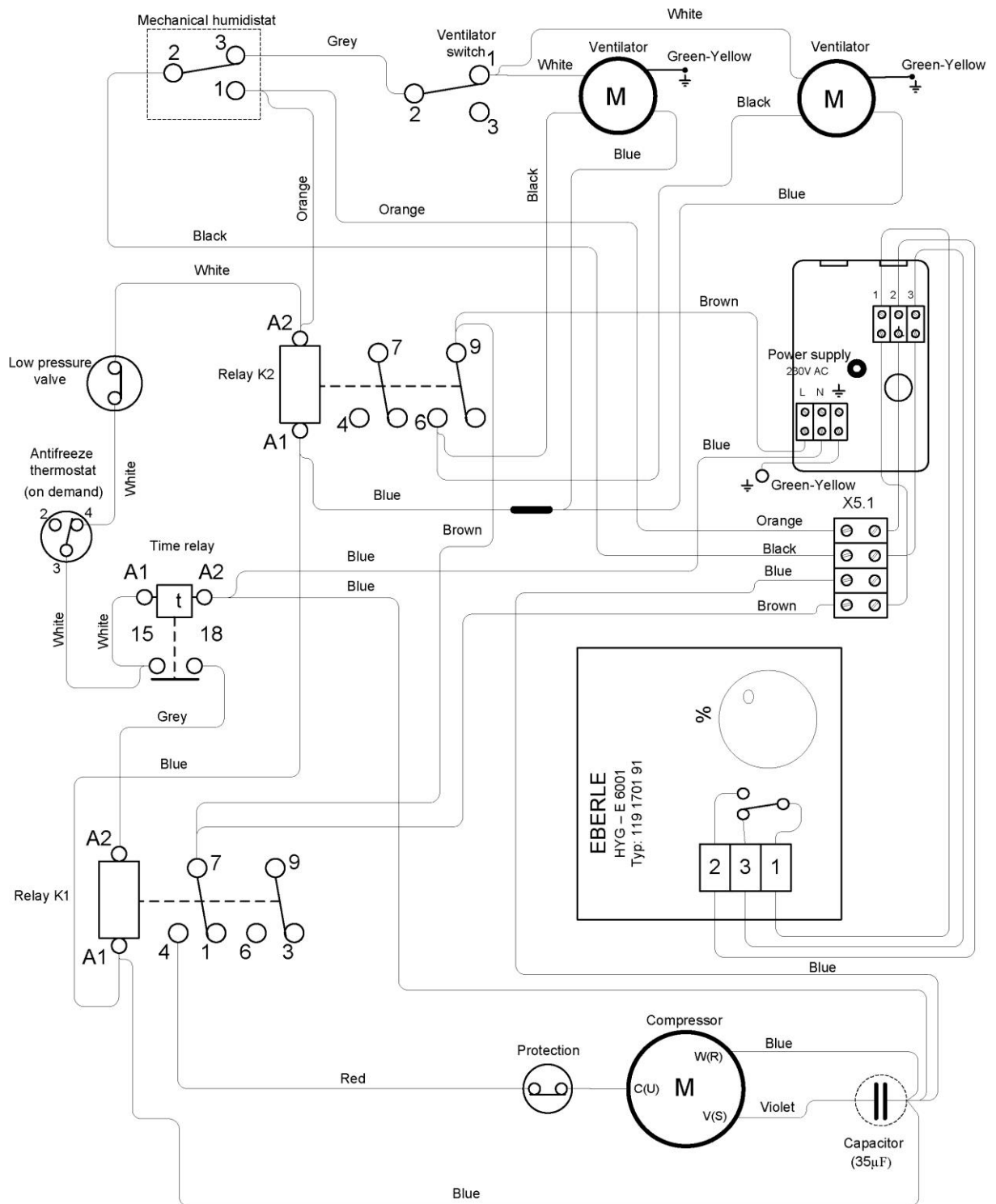

DRY 500.1 - 4 way valve

17.3.2017

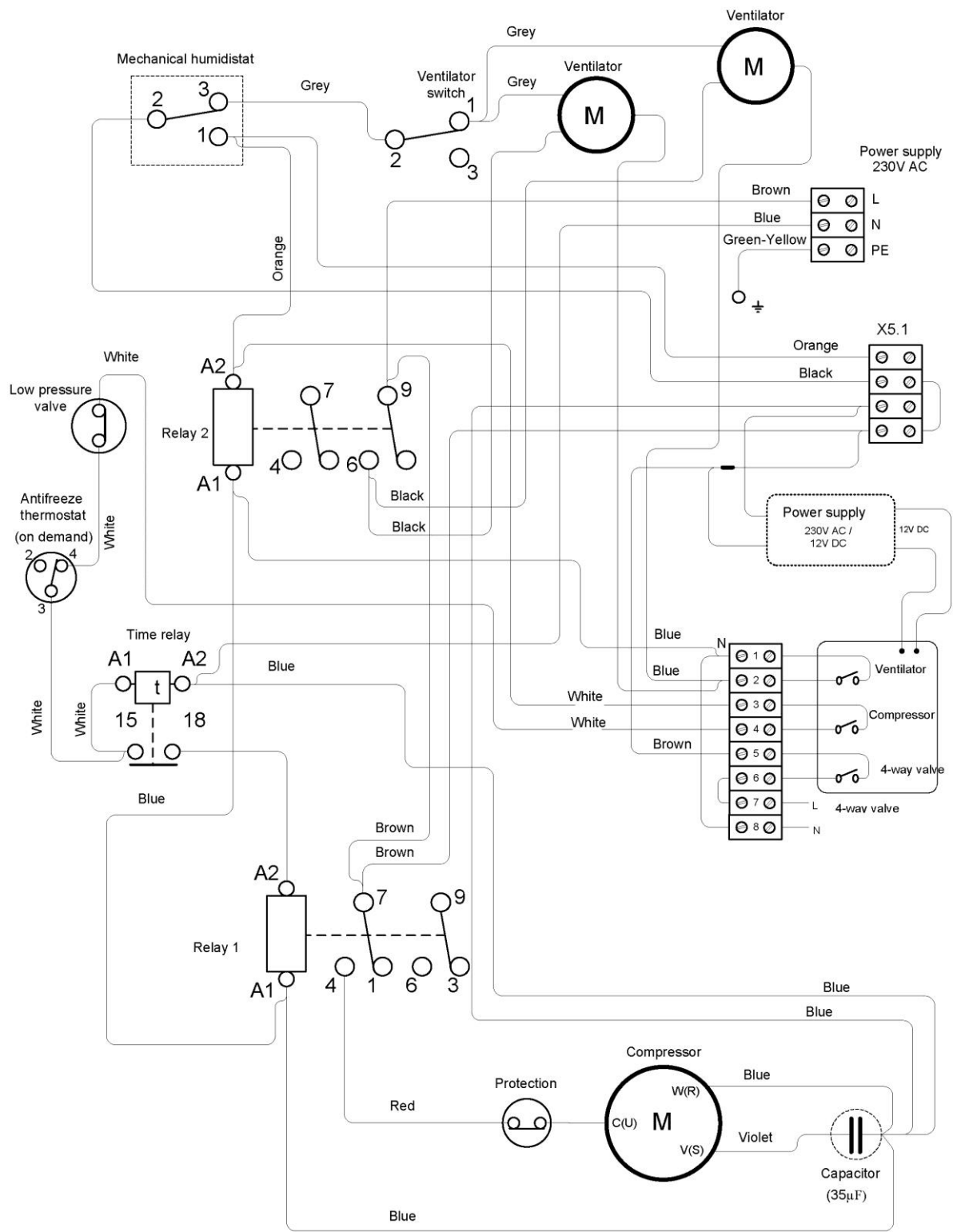

8.12.2020

DRY 500.1 (A1 A2)

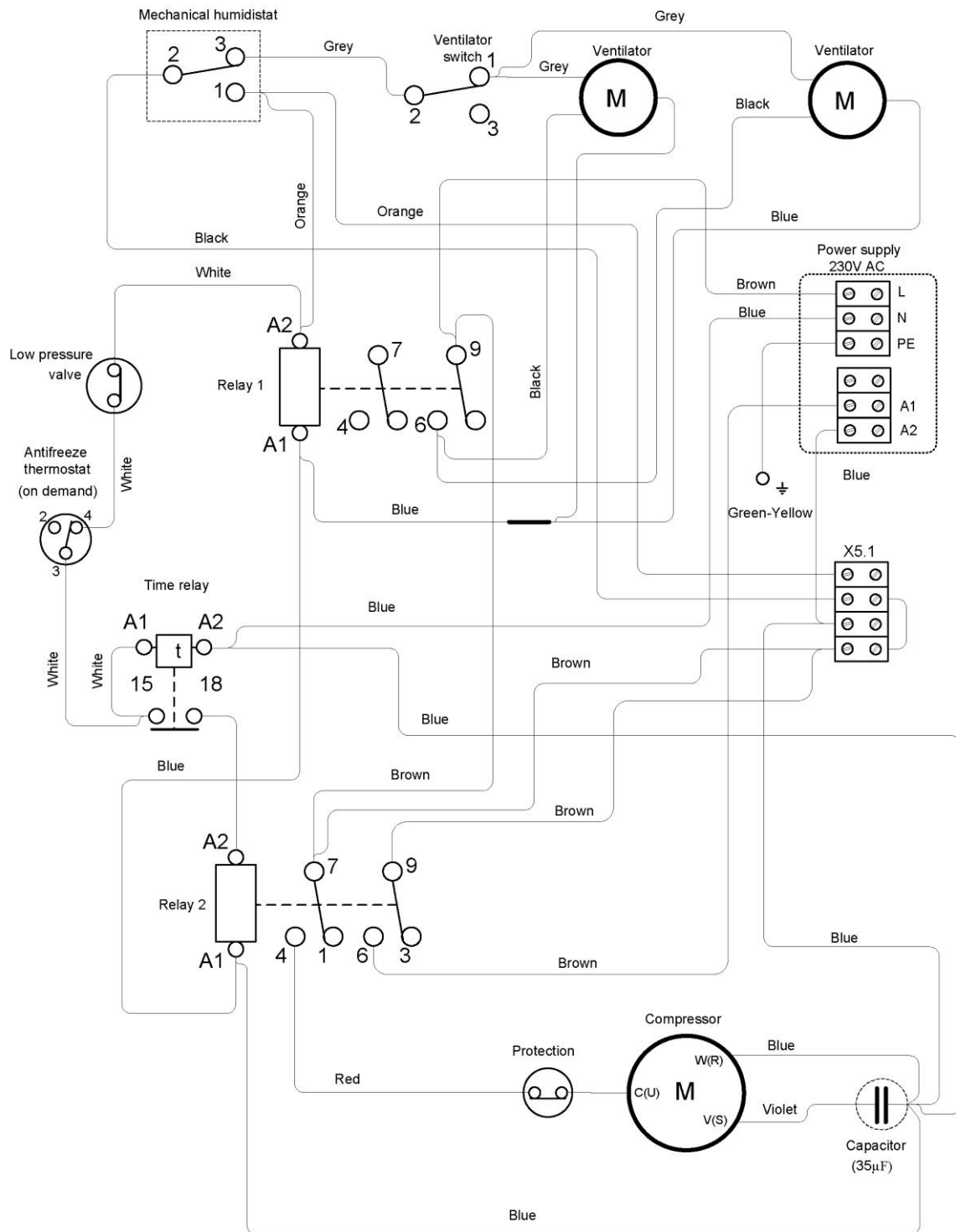

Note: A1-phase A2 - zero for control of cooperating elements for fresh outdoor air supply - louver slats with servo drive and wall exhaust fan

6.1.4 ELECTRICAL CONNECTION SCHEME of DRY 500 – ADVANCED CONNECTION of DRY 500.2

17.3.2017

DRY 500.2

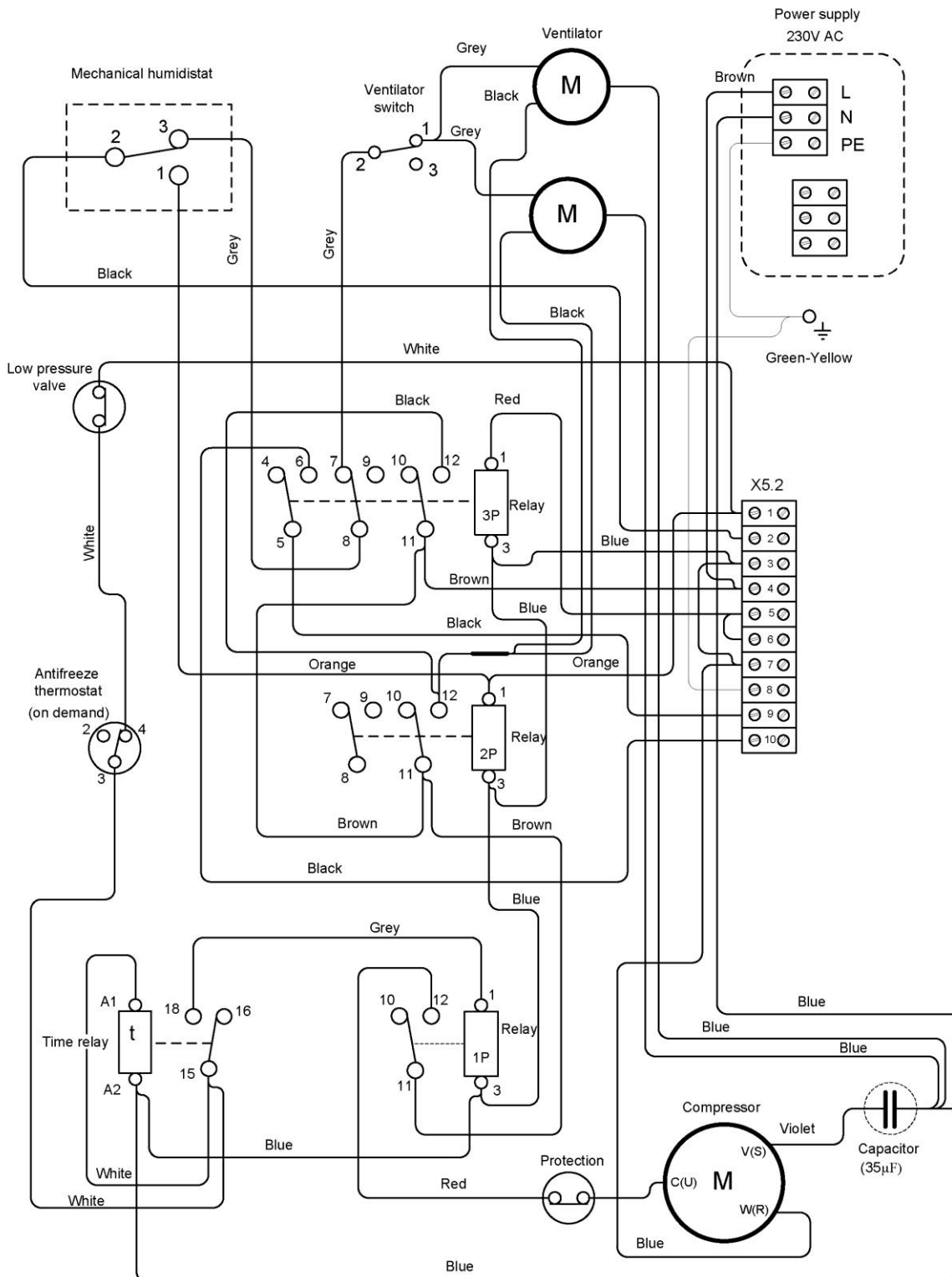

DRY 500.2 + El. heating 2000W

(a) 2017

17.3.2017

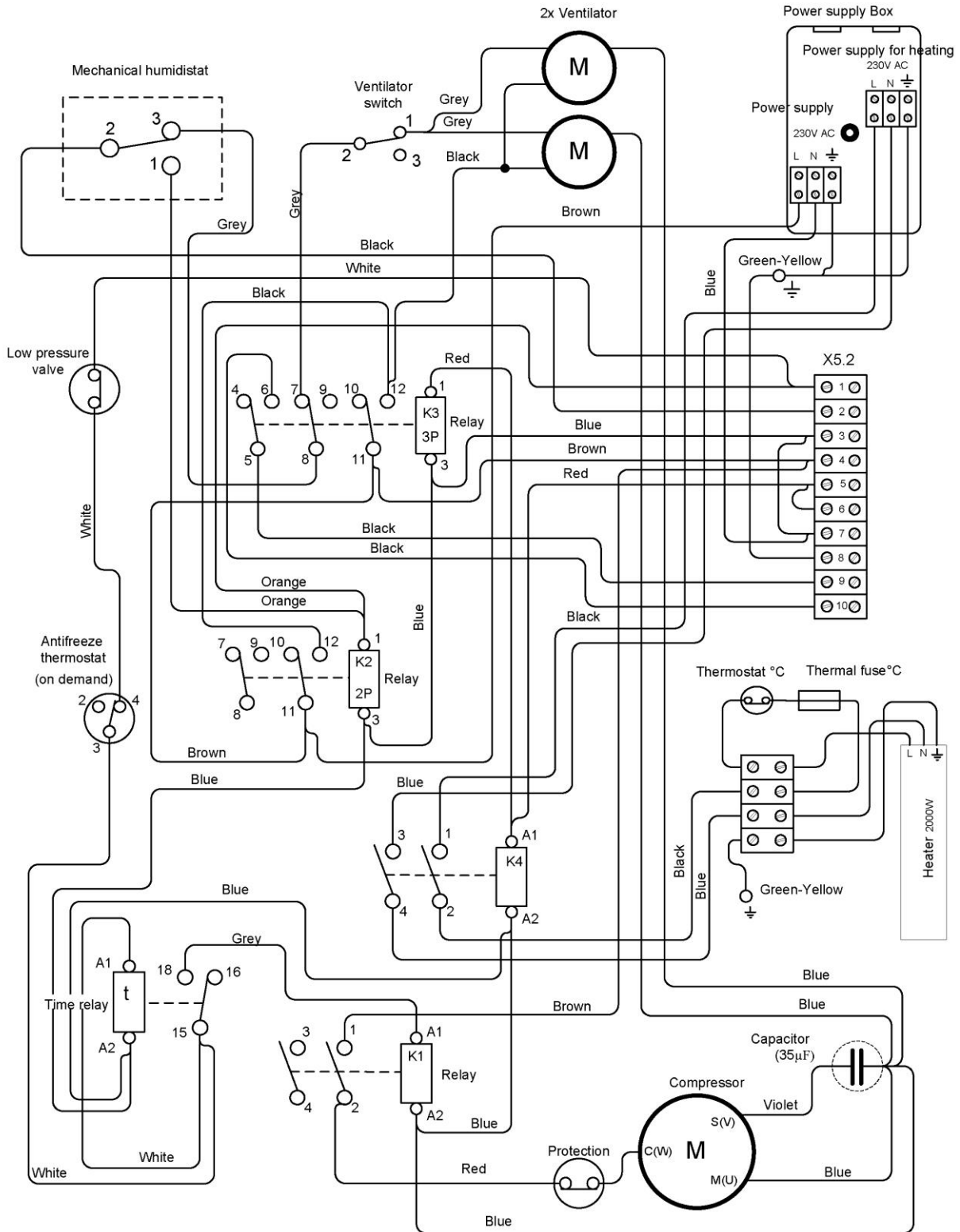

7 SUMMER SHUT DOWN

Users of indoor pools take the opportunity to shut down the dehumidifier for the summer. This is mainly due to favorable weather conditions during the summer - dry and warm weather. In this case, the natural air exchange regulates the humidity in the pool hall for several weeks/months of the year. However, with rapid weather changes (such as during rainy days), it can result in high humidity in your pool hall.

In this case, make sure that:

1. The dehumidifier circuit breaker is switched off (ie the dehumidifier has no power supply).
2. The dehumidifier cleans the air filter of dust or other contaminants that could settle and harden during downtime and be more difficult to remove later.
3. The dehumidifier is dried, the condensing tray does not contain water.
4. Make sure that the air inlet and outlet areas on the dehumidifier are adequately covered and protected from chlorine or other chemicals, especially the fan bearings. Failure to do so may result in bearing corrosion and damage to the dehumidifier.
5. Even during shutdown, we recommend releasing the dehumidifier at least once a month to prevent the fan grease from solidifying, after a few months the fan would not have to start at all.
6. **The manufacturer points out that during decommissioning of the dehumidifier, the humidity is not regulated in any way by the device and the device does not provide any drying function.**
7. **Make sure that the dehumidifier cannot be switched on when it is covered. This could cause the device to overheat and be damaged.**

7.1 Troubleshooting – save time and money

Error	Case / Description	Solution
Device does not work at all	Breaker out	Turn on the breaker
Device does not work at all	Circuit breaker out	Turn on the circuit breaker
Device does not work at all	Power supplier energy failure	Wait for the power to recover
Device doesn't dehumidify	The fan does not run or does but the dehumidifier does not dehumidify	Check the set value of the required humidity. If it is higher than the set value, set it to a lower value
Device doesn't dehumidify	4 min. after the fan has started, the compressor will also start but will switch off immediately after a few seconds	Check electronic components - compressor thermal fuse, switching relay, time relay, pressure switch
Device doesn't dehumidify	4 min. after the fan has started, the compressor will also start but only for a few minutes and then switch off	Check the refrigeration circuit - refrigerant may leak
The walls are wet	The device is dehumidifies	Undersized dehumidification capacity. It

	but the walls are wet	needs to be supplemented with another dehumidifier.
--	-----------------------	---

7.2 Maintenance instructions

The device must be inspected and cleaned by a specialist at least once a year. This is essential to ensure the longevity and reliable operation of the equipment.

- Fixing the unit - visual inspection – is the unit OK? No cracks / damage / bends?
- Unit check - clean air inlet and outlet? No objects blocking air circulation?
- Air filter (if included) - cleaned air filter? Air filter inside?
- LPHW - connection is OK? No leakage? Is there hot water inside when turned on?
- Condensate drain - visual inspection - is it drained correctly? Does it clean from dust? No vibrations? No leakage? No water stains on the ceiling or wall?
- Electrical connection - visual inspection - is the connection OK? No burns? No damage? No odour?

7.3 Cleaning by superchloring

Although DRY300 / 400/500 are made of the most durable materials, chlorine is a very aggressive substance. The typical chlorine content in the pool air is up to 1.0 ppm. DRY300 / 400/500 are equipped with special chlorine protection, but cannot protect the unit in an environment with a chlorine content higher than 3.0 ppm. When cleaning the pool hall with superchlorination, it must be remembered that the DRY300 / 400/500 must be switched off, as the chlorine concentration during superchlorination reaches up to 24 ppm. The unit must be switched off and ideally covered. Restore unit function after superchlorination and room ventilation.

7.4 Operation during construction

When you run the device in a pool that is still under construction, run it for a minimum of time. Do not turn on the device for more than a few minutes. Dust present in the air can collect on the heat exchanger and reduce the water collection capacity. Perform an initial test and demonstration, but leave the unit turned off and covered until the pool is completely constructed. **Make sure that the dehumidifier cannot be switched on when it is covered. This condition would overheat the device and damage it.**

7.5 microLIGHT+

The DRY300 / 400/500 can be equipped with the unique Microwell microLIGHT + system. It is a built-in LED strip that is located inside the unit. microLIGHT + will signal the current color humidity level.

<p>BLUE - low humidity GREEN - ideal humidity YELLOW - humidity rises above a critical level ORANGE - humidity rises above a critical level RED - humidity too high</p>

The ideal humidity in swimming pools is between 55% and 65% relative humidity. Humidity above 70% is too high and constantly deteriorates the materials in the pool and creates a favorable environment for bacteria. Moisture below 40% dries the mucosal tissue and is usually considered "dry". With microLIGHT+ you don't have to understand any image. If it's green, everything's fine. If it's red, you have a problem.

microLIGHT+ will also signal if your humidity is rising. For example, if you have a covered pool and the humidity is fine, you will see a green light. When you uncover it and start swimming, microLIGHT+ may turn yellow, orange or red after a while. This indicates that your humidity is rising. Don't be disturbed, it's normal. When you stop using the pool and cover the water surface, the dehumidifier should dry the air in a few hours at the latest (depending on the size of the pool) and the color should return to normal - Green. If red persists for more than 1 day, please check the device.

8 WARRANTY CONDITIONS

The device is covered by a warranty period of 2 years. The warranty period can be extended by your reseller. Please contact your reseller or distributor if the warranty should be applied to the dehumidifier.

Please consider the following Microwell disclaimer under warranty. No claim will be accepted if:

1. The dehumidifier was used incorrectly, i.e. not the way as specified and described in this manual or in violation of this user manual, resp. against the safety precautions listed in this manual.
2. The dehumidifier has been installed incorrectly, other than as described in these operating instructions or in violation of this user manual.
3. The dehumidifier has been put into operation by an unauthorized person.
4. The air flow in the dehumidifier is outside the defined limits.
5. The device has been subjected to mechanical damage / forcible or any unauthorized action has been taken on the design of the unit - welding, soldering or mechanical damage by scratches, mixtures, compression, pipe rupture, etc. Without mechanical damage, the complaint is accepted, unless a written complaint is made with the equipment supplied by the carrier.
6. The chemical conditions in the pool were not within the defined limits (see the table of permitted chemical values below).
7. The dehumidifier has been exposed to frost or high temperatures outside the operating temperature range.
8. Power supply. voltage insufficient or otherwise incorrect.
9. Switching the dehumidifier on/off by interrupting the electrical power supply during operation. (Device remains in standby by setting the humidity on the hygostat, e.g. set to 90%).



When requesting warranty, contact your distributor and have the device identifiers ready, i.e. model, serial number and date of purchase. Please describe the genesis of the failure. This will speed up the complaint handling process.

Acidity / pH level:	pH	7,4 +/- 0,4
Total alkalinity, CaCO ₃	ppm	80-120
Total hardness, CaCO ₃	ppm	100-300
Total dissolved dry matter	ppm	max. 3000
Maximum salt content (standard dehumidifier)	wt/wt	0.3% (3,000 ppm, 3 kg of salt per 1 m ³ of water)
Maximum salt content (dehumidifier with SALT+/SULPHUR+ treatment)	wt/wt	3% (30,000 ppm, 30 kg of salt per 1 m ³ of water)
Free chlorine range	ppm	1,0-3,0
Superchlorination	ppm	max. 30 ppm/max. 24 hours
Bromine	ppm	2-3
Baquacil	ppm	25-50
Ozone	ppm	0,8-1,0
Maximum copper content	ppm	max. 2
Aquamatic lone cleaner	ppm	max. 2
Tarn clean cleaner	ppm	max. 2
Sherwood cleaner	ppm	max. 2

Tab.: Permitted chemical values

TRANSPORTATION



The dehumidifier must only be transported in the original packaging in an upright position. When transporting, secure the dehumidifier against tipping over and falling. Never place the dehumidifier on its side! There is a risk of serious damage to the compressor!

Damage during transport is never covered by the warranty! If you receive the shipment, check the integrity of the packaging and document any defects.



TECHNICKÝ SKÚŠOBNÝ ÚSTAV PIEŠŤANY, š.p.
Certifikačný orgán certifikujúci výrobky
Product Certification Body
Krajinská cesta 2929/9, 921 01 Piešťany
Slovenská republika/Slovak Republic



CERTIFIKÁT ZHODY CONFORMITY CERTIFICATE

č./No. 231299156

Výrobca/Manufacturer: **MICROWELL, spol. s r.o**
SNP 2018/42
927 00 Šaľa, Slovenská republika / Slovak Republic

Výrobok/Product: **Bazénový odvlhčovač MICROWELL**
Swimming pool dehumidifier MICROWELL

Typ/Type: **DRY 500 WAVE**

Odvođené typy / Derived types: **uvedené na druhej strane / see the next page**

Tento certifikát zhody potvrdzuje, že výrobok spĺňa základné požiadavky na bezpečnosť podľa nasledovných smerníc ES/EÚ nového prístupu v ich platnom znení:
This conformity certificate confirms the conformity of the product with essential safety requirements of the following EC/EU New Approach Directives as amended:

2014/35/EÚ Smernica o LVD 2014/35/EU LVD Directive
2014/30/EÚ Smernica o EMC 2014/30/EU EMC Directive

Harmonizované normy použité pre posúdenie zhody:
Harmonized standards used for the conformity assessment:

EN 60335-1:2012/AC:2014/A11:2014/A13:2017/A1:2019/A14:2019/A2:2019/A15:2021
EN 60335-2-40:2003/A11:2004/A12:2005/AC:2006/A1:2006/A2:2009/AC:2010/A13:2012/AC:2013
EN 61000-3-3:2013

Iné normy použité pre posúdenie zhody:
Other standards used for conformity assessment:

EN IEC 55014-1:2021
EN IEC 55014-2:2021
EN IEC 61000-3-2:2019/A1:2021
EN 61000-3-3:2013/A1:2019/A2:2021/AC:2022-01

Certifikát je vydaný na základe skúšok vzorky typu výrobku. Výsledky sú uvedené v Správe o posúdení zhody č. 230500076 zo dňa 27.04.2023

The certificate has been issued on the basis of the tests of the product type sample. The results are recorded in the Conformity assessment report No. 230500076 dated 27.04.2023

CE označenie môže byť použité iba v prípade posúdenia zhody so všetkými príslušnými smernicami ES/EÚ
mark can be used only in the case of conformity assessment according to all relevant EC/EU Directives

Dátum vydania/Issue date: 28.04.2023
Platnosť do/Expiry date: 27.04.2026
Vydanie /Issue: 1

Ing. Dušan HANKO
vedúci certifikačného orgánu
certifikujúceho výrobky
Head of Product Certification Body

Odvodené typy / *Derived types:*

DRY 300, DRY 400, DRY 500, DRY 800 a DRY 1200 v prevedení WAVE, METAL, SILVER a DUCT v kódovom označení:

DRY 300, DRY 400, DRY 500, DRY 800 and DRY 1200 in make of WAVE, METAL, SILVER a DUCT in code marking:

DRY300W	DRY300M	DRY300S	DRY300D
DRY400W	DRY400M	DRY400S	DRY400D
DRY500W	DRY500M	DRY500S	DRY500D
DRY800W	DRY800M	DRY300G	DRY800D
DRY1200W	DRY1200M	DRY400G	DRY1200D

Tento certifikát je vydaný za nasledujúcich podmienok:

1. Certifikát sa vzťahuje na typ výrobku a jeho varianty uvedené vo vyššie uvedenej správe o posúdení zhody.
2. Tento certifikát sa nevzťahuje na výrobný proces/vnútropodnikovú kontrolu.
3. Certifikát neznamená, že certifikačný orgán vykonáva dozor alebo kontrolu výroby.
4. Výrobca musí zabezpečiť zhodu následne vyrábaných výrobkov s certifikovaným typom.
5. Zmeny, ktoré majú vplyv na zhodu s certifikačnými požiadavkami môžu podmieniť ďalšiu platnosť certifikátu tým, že sa bude vyžadovať preukázanie zhody s podmienkami, za ktorých bol certifikát udelený, alebo dodatočným hodnotením.
6. Držiteľ tohto certifikátu musí dodržiavať podmienky uvedené vo Všeobecných pravidlách pre certifikáciu výrobkov, ktoré sú voľne dostupné na stránke www.tsu.sk

This certificate is issued under the following conditions:

1. *The certificate applies to the product type and its variations specified in the above mentioned Conformity Assessment report.*
2. *The production process/factory production control is not covered by this certificate.*
3. *The certificate does not imply that the certification body has performed any surveillance or control of the production process.*
4. *The manufacturer shall ensure the conformity of subsequent production items with the certified type.*
5. *Changes that may have an impact on maintaining conformity with the certification requirements may require confirmation of the validity of the certificate by demonstrating compliance with the conditions under which the certificate was issued or by conducting an additional evaluation.*
6. *The holder of this certificate must keep the conditions specified in the General Rules for Product Certification, which are freely available at www.tsu.eu*



Notes:

Notes:

Notes:

Notes:

Manufacturer:

MICROWELL, spol. s r.o.
SNP 2018/42, 927 01 Šaľa, Slovakia
tel.: +421/31/770 7082
e-mail: microwell@microwell.sk
www.microwell.eu

Distributor:

Made in: EUROPEAN UNION (SLOVAK REPUBLIC)
Country of Origin: EUROPEAN UNION (SLOVAK REPUBLIC)

