



MICROWELL



Installation and user manual

POOL DEHUMIDIFIER

Model: DRY 800 WAVE

DRY 1200 WAVE



Version: 01/2024





Thank you, for purchasing a Microwell swimming pool dehumidifier. You have probably chosen the best and most energy efficient dehumidifier for your pool. Before you use this device, it is necessary to carefully read the entire Installation and user manual. It is not allowed to commence the heat pump installation or operation unless full content of this Installation and user manual is understood and acknowledged. Please keep the Installation and user manual available in the case of any future reference is required. Please provide this information also to each user of the device. Please

mind local regulations in your country regarding installation and usage of this heat pump which are valid in addition to this User manual.

Contents

1. WASTE DISPOSAL INFORMATION.....	3
2. SAFETY MEASURES.....	3
2.1 ELECTRICAL SAFETY	3
2.2 USAGE PRECAUTIONS	4
2.3 HANDLING PRECAUTIONS	5
3. PRODUCT DESCRIPTION	6
3.1 DESCRIPTION OF BASIC PARTS.....	9
3.2 FRESH AIR SUPPLY (ON DEMAND AS ACCESSORY)	10
4. HANDLING INSTRUCTIONS.....	10
4.1 MACHINE HANDLING	10
4.2 HUMIDISTAT.....	12
4.3 HUMIDITY CONTROL BY REMOTE CONTROLLER - ON DEMAND.....	12
4.4 HUMIDITY CONTROL BY EXTERNAL WIRED HUMIDISTAT EBERLE	15
4.5 FAN REGULATION.....	15
4.6 COMPRESSOR REGULATION.....	16
5. INSTALLATION MANUAL	16
5.1 LOCATING THE DEVICE	17
5.2 INSTALLATION OF DEVICE.....	19
5.3 CONDENSATE DRAIN.....	30
5.4 MAIN POWER SUPPLY CONNECTION.....	31
5.5 LPHW HOT WATER INSERT FOR ADDITIONAL HEATING – ON DEMAND	36
5.6 ELECTRIC HEATING	39
5.7 AIR FILTER – ON DEMAND.....	39
6 TECHNICAL DATA	43
6.1 TECHNICAL DATA CHART*	43
7 SUMMER SHUTDOWN	54
7.1 TROUBLESHOOTING – SAVE TIME AND MONEY	54
7.2 MAINTANANCE INSTRUCTIONS	55
7.3 CLEANING BY SUPERCHLORINATION	55
7.4 OPERATION DURING CONSTRUCTION	55
7.5 MICROLIGHT+	55
8 WARRANTY CONDITIONS.....	56

1. WASTE DISPOSAL INFORMATION

If you are using the heat pump in European countries, you must follow these instructions:

DISPOSAL: Do not dispose this product as unsorted municipal waste. It is prohibited to dispose this heat pump in domestic / household waste. It is prohibited to dispose this appliance into forests or natural landscape. This could lead into local soil pollution. Collection of such waste must be treated individually.



DISPOSAL POSSIBILITIES:

1. The municipality has established a collection system where electronic waste can be disposed.
2. When buying a new product, the retailer or the manufacturer may take back the old appliance free of charge.
3. Old appliance may contain valuable resources which could be sold to scrap material dealers.
4. Disposal of packaging materials such as carton box or plastic / bubble foil can be recycled. Please use your local waste separation services.



2. SAFETY MEASURES

The device is primarily designed for use in indoor swimming pools, smaller pools, spas or saunas. Alternative use is in laundries, drying rooms or other humid areas requiring dehumidification. See the technical data table to check model suitability for a pool room and pool area.

For proper and optimal operation of this device, it is necessary to keep the air temperature in the pool hall 2 - 3 °C higher than the actual water temperature in the pool. It is also necessary to maintain the air temperature in the pool hall within the operating temperature range of the dehumidifier (specified in the Technical Data section), based on the specific selection of the operating temperature of the accessories selected for the specific equipment. Lower air temperatures outside the operating temperature range can damage the device due to freezing. Higher temperatures outside the operating temperature range may damage the unit due to overheating of the unit.

It is necessary to follow the instructions in this Installation and user manual and local regulations in your country that regulate the installation and usage of this device. Incorrect, improper or operations contradictory to this User's manual may lead to injury or property damage and will lead to loss of warranty. To prevent injury or property damage the following instructions must be followed:

2.1 Electrical safety



- The device operates at dangerous electrical current.
- Only authorized persons with particular electro-technical qualification can manipulate with unit.
- Danger of electrical shock.
- Do not exceed the required power supply.
- Do not turn a device that shows signs of possible damage such as broken packaging, broken or otherwise damaged unit's chassis or cover, smoke, smell, damaged power cord etc. on.
- **It is necessary to use appropriate Residual current circuit breaker (RCD) for connection of the dehumidifier to main power supply.**
- Do not manipulate device with wet hands.

- Do not clean device with water.
- Before cleaning the device, unplug the power cord and switch off the circuit breaker of the unit's power supply.
- Installation, service or repair must be performed by a qualified technician.
- When the device is not intended to be used for a longer time, we recommend switching the circuit breaker of the unit's power supply off.
- Unit must be installed in vertical position to avoid condensate water to enter electrical part of the unit.
- It is forbidden to install the unit close to devices that may cause electrical or frequency disturbance such as welding machines, motors or rotors, WIFI/WLAN routers or repeaters.
- It is forbidden to alter electrical installation of the device. It is also forbidden to alter any other part or functionality of the device.

2.2 Usage precautions



- Do not cover or block the intake or exhaust openings. It is forbidden to block or cover the intake or exhaust openings with clothes, towels, buckets, canoes, ceiling beams, etc.
- **Do not install or place any heating appliances close to intake grilles / louvers. It could continually overheat the dehumidifier and result in its malfunction or damage.**
- Do not climb or sit on the unit.
- Do not place any objects on the top of the unit (e.g. boxes, flower vases, etc.)
- Never push any objects into any hose or hole.
- Do not spray any flammable substances on the device, as this may cause a fire.
- Do not clean the device with aggressive cleaning agents, which may damage or deform the unit.
- Use the device only for the purpose for which it was manufactured, as described in the instruction manual. Do not use parts that are not recommended.
- Do not drink or otherwise use condensate that has been aspirated by the unit. Do not return water to the pool. Water can be contaminated with bacteria.
- Children are not allowed to operate, touch or play with the unit.
- **Children are not allowed to handle the packaging, plastic / bubble foil. Risk of suffocation!**
- **Prevent children from being injured or injured by handling the unit, its parts, or its packaging. Small parts, such as the screws can be swallowed by children and cause injury.**
- Do not leave the children in the swimming pool hall unattended.

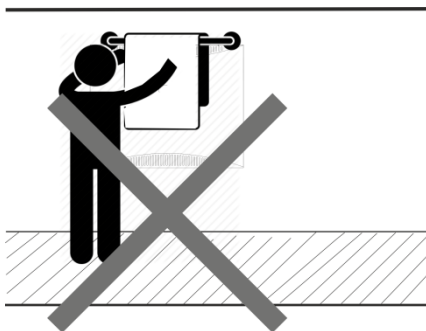

- Do not dry wet towels or swimsuits on the unit and do not put other objects on top of it (e.g. boxes, vases with flowers, etc.).

2.3 Handling precautions

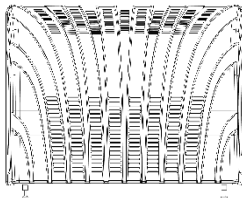
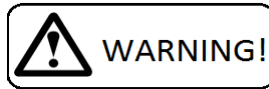

Keep in vertical position for 2 hours



Leave the unit in a vertical upright position for at least 2 hours before mounting. It is necessary to stabilize the refrigerant charge and especially to return the oil to the compressor tray. Oil could get out of the tray during transport and handling, and this could adversely affect the function of the dehumidifier.



- Transport in a horizontal position or overturning the unit may damage the compressor, which may result in malfunction or damage to the unit and will void the warranty.
- The device must be handled carefully and with special care to avoid mechanical damage.

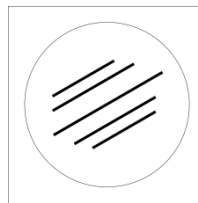
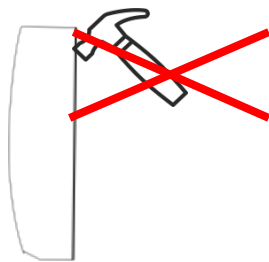

Beware of scratches. Handle the device carefully. Avoid contact with surfaces that may scratch the device.

- It is forbidden to exert any unsuitable mechanical force on the unit, which may cause mechanical damage to the device

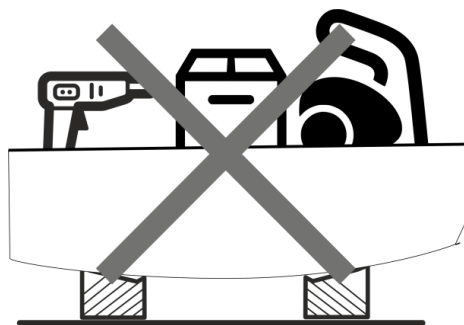

- It is forbidden to freely drop the device on the ground or any hard or rough surface that can lead to a hard impact of the device and scratch the cover. As the owner of the area make sure that your installer does not damage the cover or a part of the device during handling and installation.

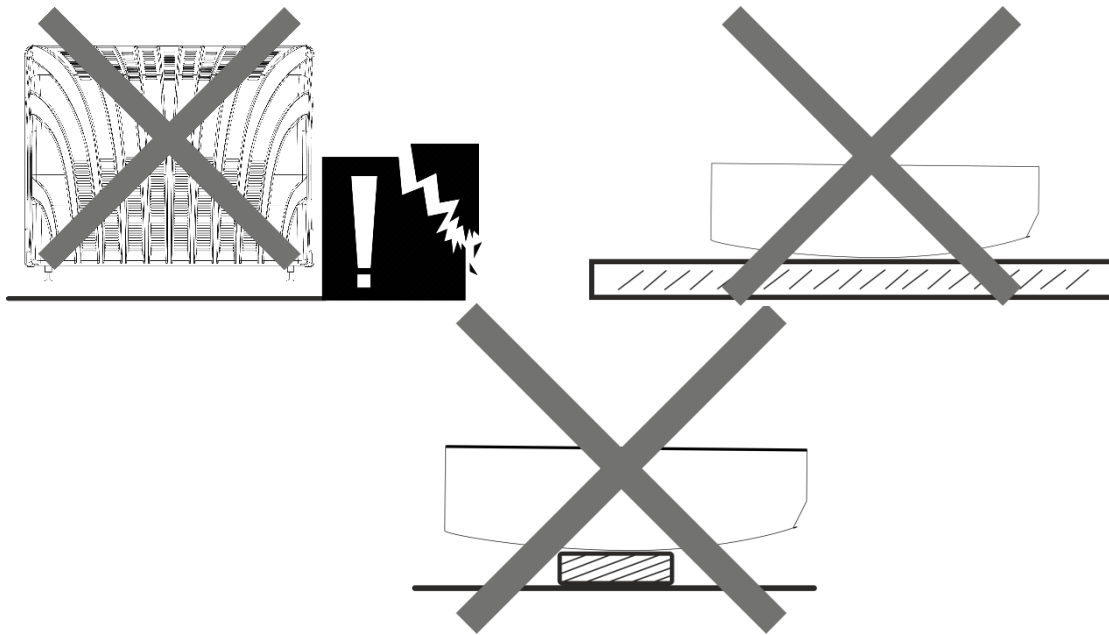

Please notify your reseller or distributor if the delivered unit had been damaged. The unit may appear to work fine at first, but minor damage may cause the unit to stop working properly in a short time. In this case the unit must be inspected and its further use must be approved by the seller.



- Please notify your reseller or distributor if you notice immediately after installation that the unit is not working properly.
- In case of device failure resulting from improper handling or mechanical damage (impact, hit, fall, etc.), the manufacturer reserves the right to evaluate the continuity of warranty.

3. PRODUCT DESCRIPTION

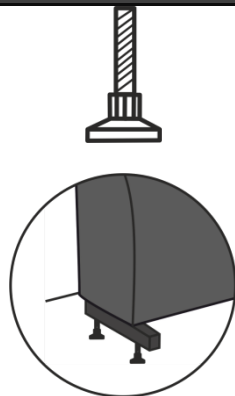

The unit was delivered in a carton box on a wooden palette. Please unpack the unit and check the content. **It should include the following:**

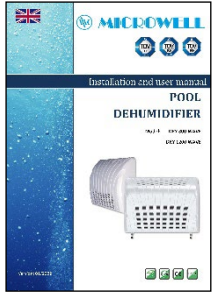
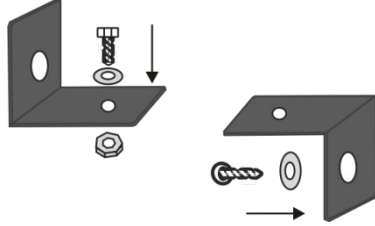

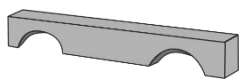

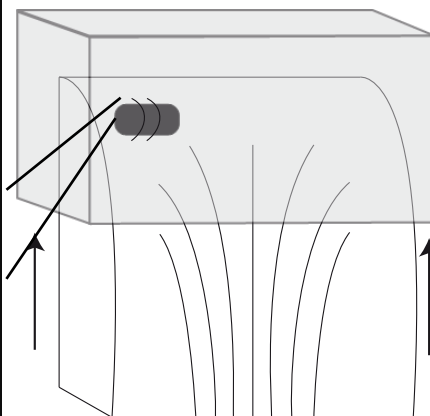

Package:

Name/ code	Image	Name/ code	Image
1 - Dehumidifier 1x		2 – Metal feet / adjustable screw with plastic heel / 4x	

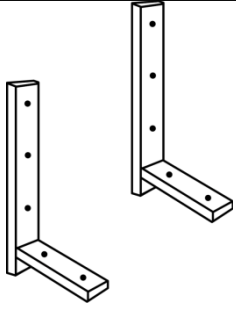

<p>3 – Condensate drain hose (illustration photo)</p> <p>1x</p>		<p>4 - Installation and user manual</p> <p>1x</p>	
<p>5 – Adjusting "L" piece</p> <p>2x</p> <p>+ screw M6 – 2x + nut MC – 1x + washer D7 – 2x</p>		<p>6 – Handling slings</p> <p>2x</p>	
<p>7 – Plastic caps</p> <p>4x</p>		<p>8 – Metal lift support</p> <p>2x</p>	





Additional accessories (to order):

Name/code	Image	Name/ code	Image
<p>1 - External wireless humidistat and thermostat DRY EASY 300</p> <p>1x</p> <p>Part of packaging (white box) located on the fan plate on the left</p> <div data-bbox="199 1624 406 1668" style="border: 1px solid black; padding: 2px;">Easy300 / Eberle</div> <div data-bbox="199 1713 406 1758" style="border: 1px solid black; padding: 2px;">Solenoid valve</div>	 	<p>2 - External wired humidistat EBERLE</p> <p>Separate small box glued to the device (cardboard box) see picture 1</p>	

<p>3 – Wall console</p> <p>2x</p>		<p>4 – Fixing screws for a cross screwdriver D6 and dowels D10 (illustration photo)</p> <p>4x</p>	
<p>5 – Defrost thermostat</p>		<p>6 - Solenoid valve - valve and coil</p> <p>1x</p> <p>Part of packaging (white box) located under the main cover on the fan plate on the left, see. picture point. 1</p>	
<p>7 – Air filter Installed inside the device</p>		<p>8 – fresh air supply adapter</p>	

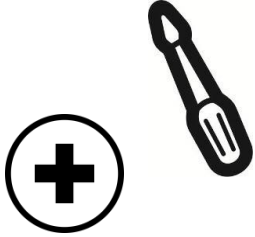
List of necessary tools (is not part of packaging):

Názov/ kód	Obrázok	Názov/ kód	Obrázok
<p>1 - Drill</p> <p>1x</p>		<p>3 – Drill bit 10mm</p> <p>1x</p>	

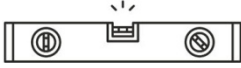
<p>2 - Phillips screwdriver</p> <p>1x</p>		<p>Vacuum cleaner and ladder</p>	
<p>5 - Small hammer</p> <p>1x</p>		<p>6 - Meter</p> <p>1x</p>	
<p>7- Spirit level</p> <p>1x</p>			

3.1 Description of basic parts

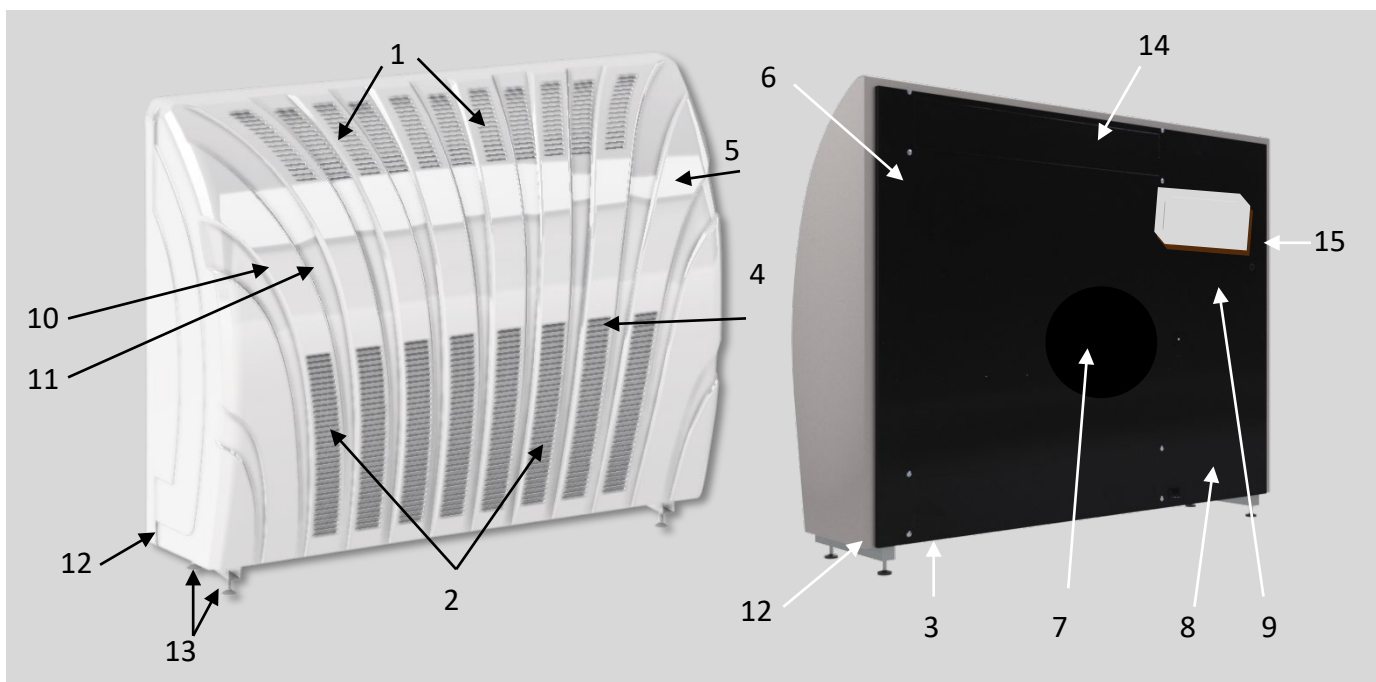

Legend:

- 1 – Air exhaust
- 2 – Air suction
- 3 – Back metal plate
- 4 – Plastic (acryl) cover
- 5 – Possible heating water supply from the right ½ “(on request as accessory)
- 6 – Possible heating water supply from the back ½ “(on request as accessory)
- 7 – Fresh air supply Ø 100 mm (on request as accessory)
- 8 – Condensate drain Ø outer 20 mm (Ø inner 16 mm)
- 9 – Power supply 230 V

- 10 - position (under the cover) of the electro wiring box
- 11 - position (under cover) of the fan mode switch
- 12 - position of the cover fixing screws (max. 1.5Nm)
- 13 - Feet
- 14 - position of the nut for screwing the locking L-pieces to the wall
- 15 – Main power supply connection (+ accessory connection such as electrical heater / Eberle)

3.2 Fresh air supply (on demand as accessory)

Each MICROWELL DRY dehumidifier has the option of fresh air supply. The air supply is located below the condenser, which effectively heats the incoming fresh air due to heat recovery.

The metal fresh air connection is supplied already mounted on the dehumidifier, but towards the inside. When installing the dehumidifier, it is necessary to remove the flange to wind it correctly (opposite to the one supplied). For example, a plastic pipe is then mounted on the flange, which conducts the air through the wall.

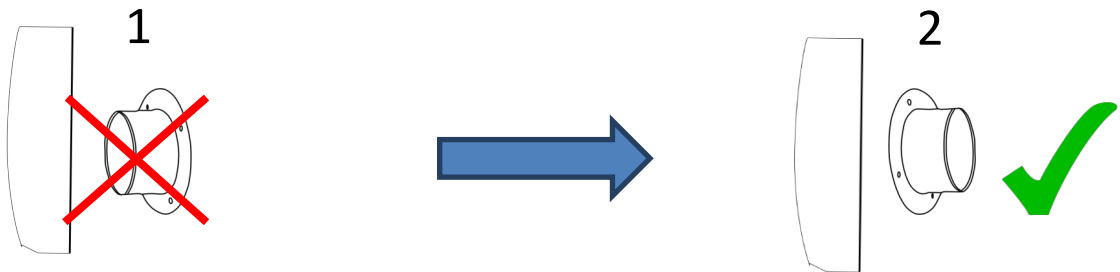

4. HANDLING INSTRUCTIONS

4.1 Machine handling

Please, follow the instructions below.

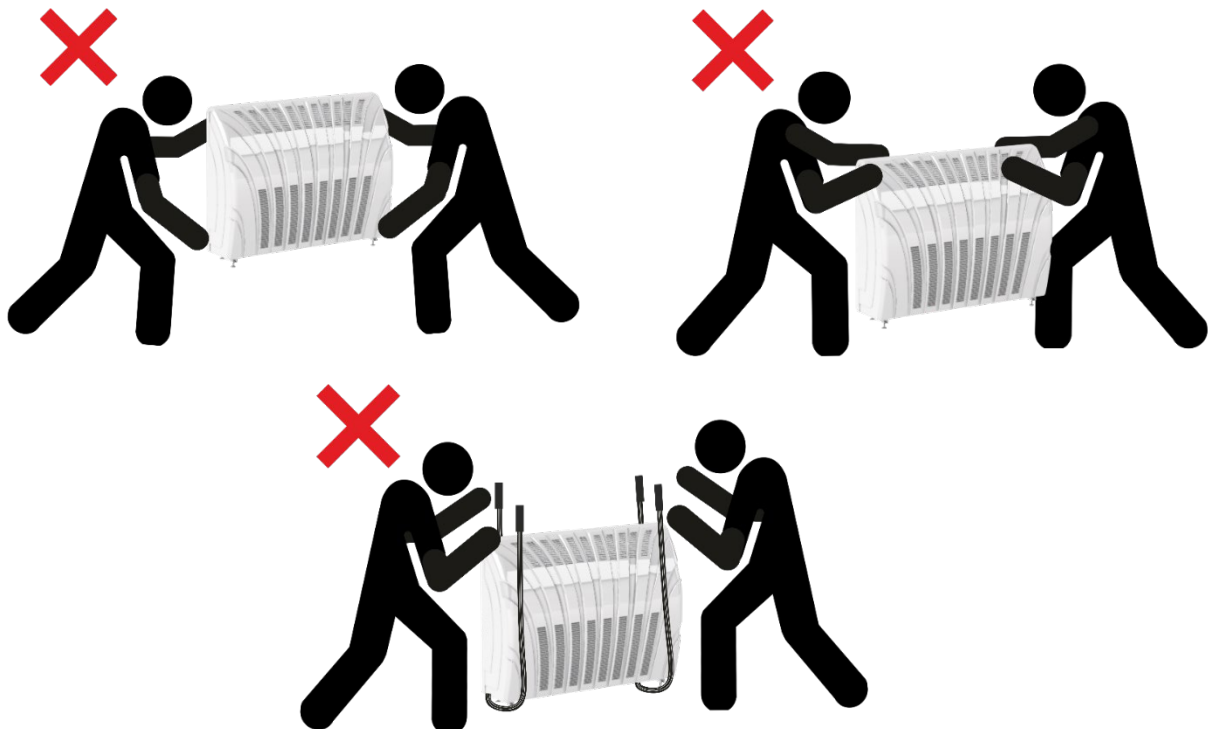

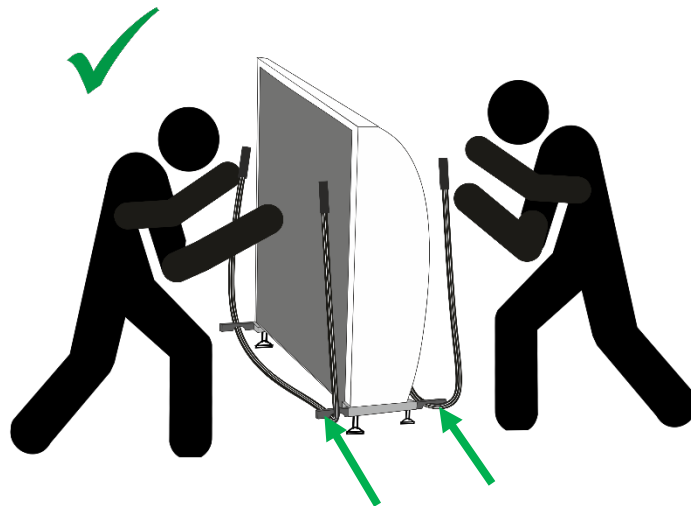

Lift support assembly:

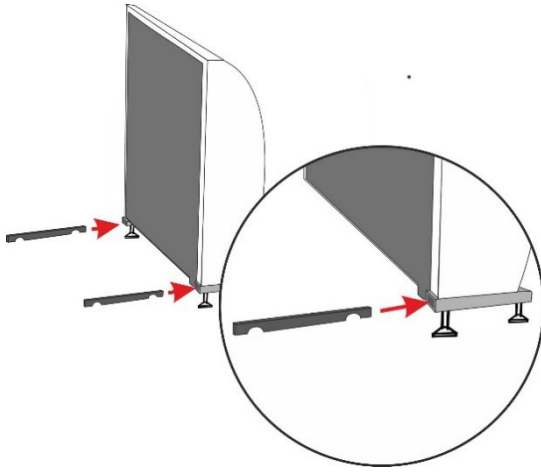
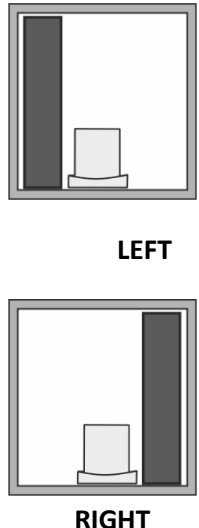
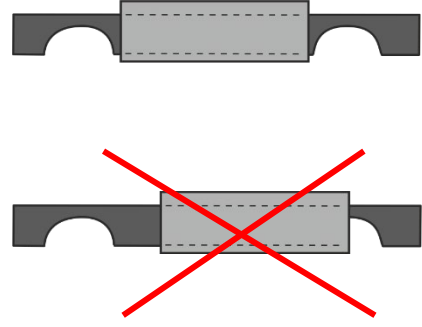
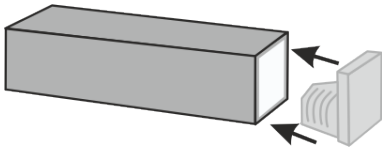
<p>1.</p> 		
<p>2.</p>  <p>LEFT</p> <p>RIGHT</p>	<p>3.</p> 	<p>4.</p>  <p>4x</p>

4.2 Humidistat

Your dehumidifier is equipped with a built-in mechanical humidistat as standard. On request, it can be equipped with an external wired humidistat, or an external wireless humidistat and thermostat. A detailed description of the operation of these controllers is described in separate manuals, which are part of their own packaging.

Picture:
Mechanical
humidistat
indicator wheel.

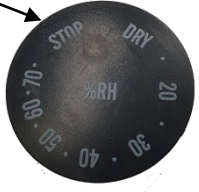

The built-in mechanical humidistat is located in the lower left part of the device (under the cover of the dehumidifier). The humidistat checks the humidity level of the sucked-in air and, depending on the set value, starts or dehumidifies. Ideal humidity of a pool hall is 55-65%. Your dehumidifier is primarily regulated by a built-in digital humidistat and thermostat. The role of the mechanical humidistat (black wheel) is to be a backup controller. Therefore, it is set to 70%. We do not recommend changing this setting.

Humidistat setting ("V").
Currently, the humidistat in the photo is set to 70%.



Humidity scale. DRY = continuous dehumidification, STOP = stop dehumidification. Values of 20-30-40-50-60-70 correspond to relative humidity.

The mechanical humidistat is a reliable way of measuring and subsequently regulating the humidity in your pool hall. Its advantage is its high reliability as it measures moisture based on the physical properties of the measuring fiber. In the case of a mechanical humidistat, a hysteresis of 4% and a maximum of 8% must be taken into account. Hysteresis is a property where the off or on is shifted to a higher or lower relative humidity value than the actual desired one.

If you use an external (wired or wireless) humidistat, a mechanical humidistat also remains installed in the device. It functions as a backup in case of failure of the external humidistat. In this case, the mechanical humidistat is set to 70%. We recommend the user not to change this setting.



The manufacturer recommends setting the required humidity value on the backup humidistat to the range of 70-80% RH. This will serve as a backup in case the digital humidistat and thermostat 1401F located on the cover switches off. The recommended setting of the digital humidistat and thermostat 1401F is in the range of 55 to 65% RH.



Please note that not all DRY800-1200 WAVE versions are equipped with this mechanical humidistat control. Please enquire at your distributor to request this information.

4.3 Humidity control by remote controller - on demand

An external wireless humidistat and thermostat DRY EASY 300 can be ordered for the pool dehumidifier as standard equipped with a built-in digital humidistat and thermostat + mechanical humidistat.

Wireless communication takes place in the 868 MHz band, where the emphasis is on the reliability and range of the controller. The dehumidifier is controlled primarily by a remote humidistat, provided that the built-in humidity controller in the dehumidifier is set to a higher desired humidity value than the remote humidistat.

External wireless humidistat and thermostat DRY EASY 300



1. TRANSMITTER

2. RECEIVER

3. ANTENNA



The manufacturer recommends setting the required humidity value on the DRY EASY 300 in the range of 55 to 65% RH.

If the backup humidistat had been set to a lower value than the DRY EASY 300 remote humidistat, the backup humidistat will take over the room humidity control and in this case the dehumidifier will not respond to signals from the DRY EASY 300 remote humidistat.

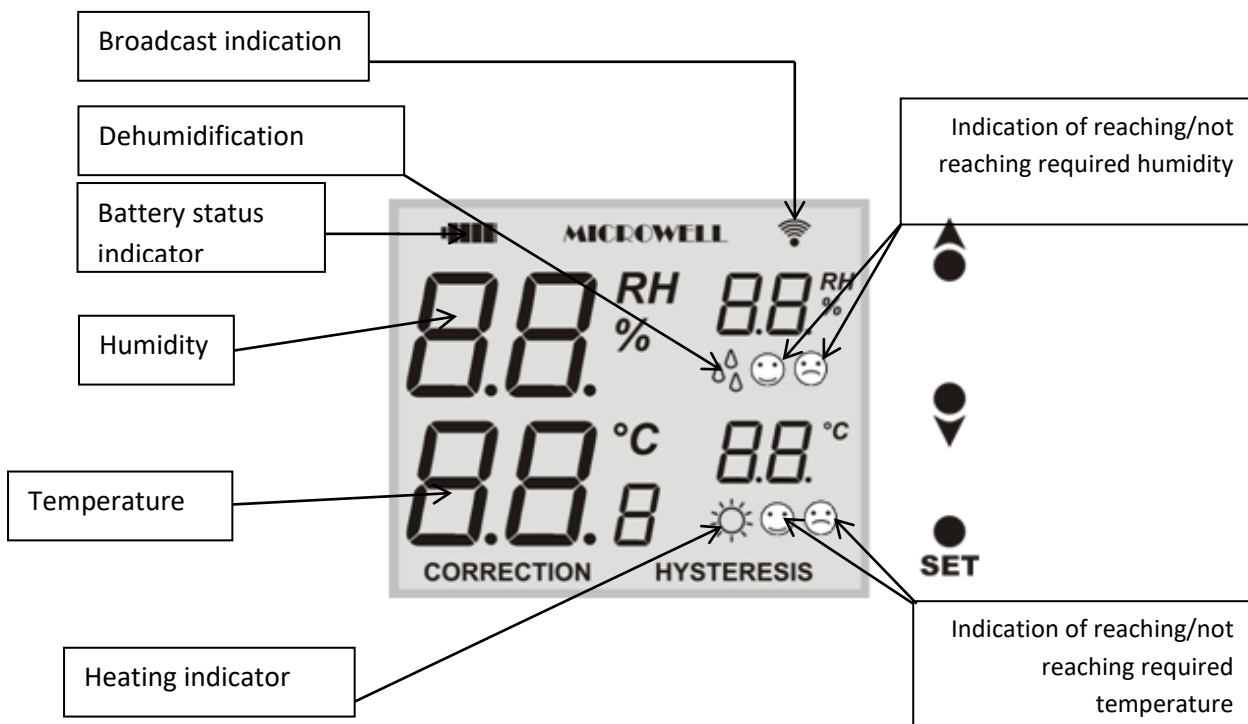

Additional functions and operation of the remote humidistat are described in the separate enclosed instructions.

Location of receiver and antenna

A: The receiver is located inside the electrical box and the antenna is located on the outside of the electrical box.

B: For TTW version /through the wall/, we recommend pulling the antenna into the pipe in the wall. Follow the picture below.

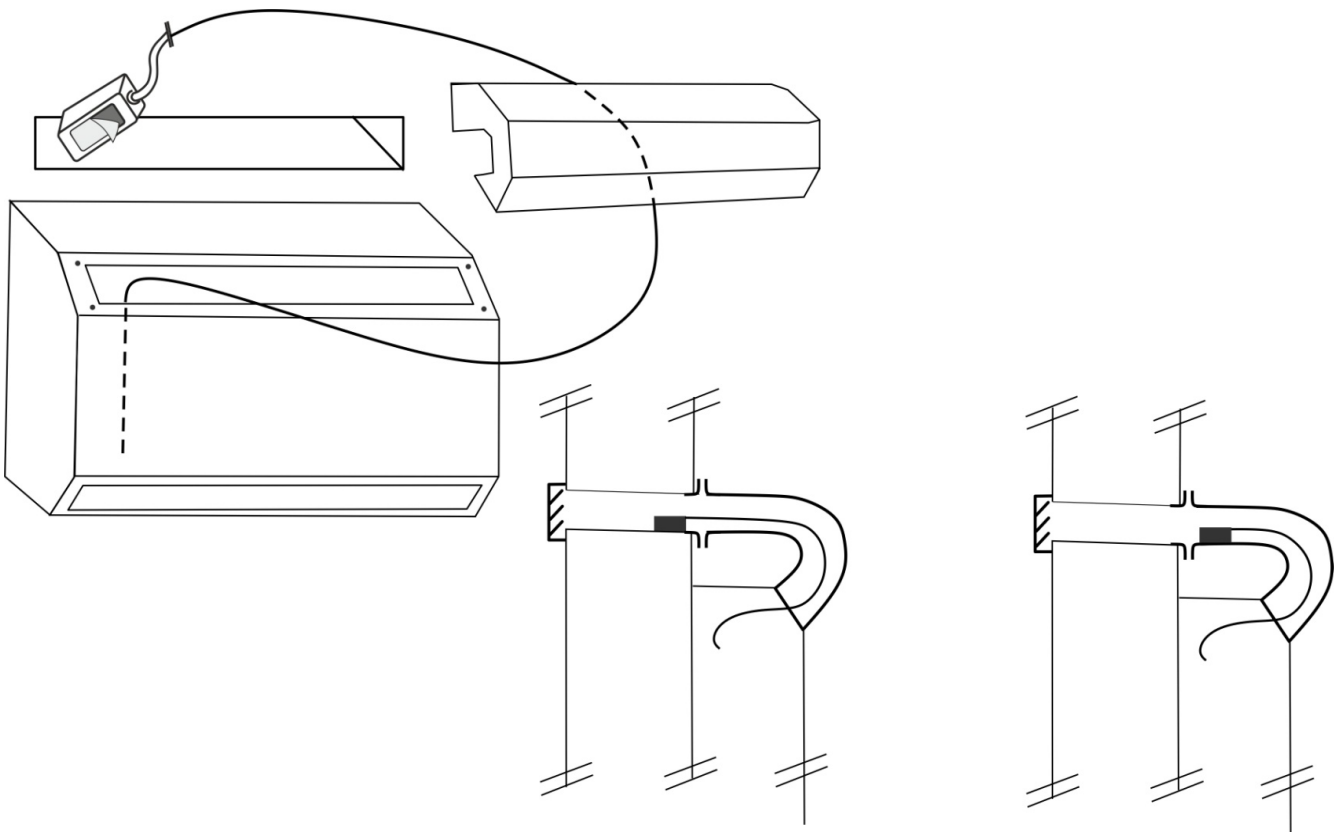

C: If your dehumidifier is also equipped with an electric heater, place the antenna on the outside of the cover. After starting the dehumidifier, test whether the signal is successfully transmitted between the transmitter (display unit) and the antenna. For example, if you set the humidity lower than the current value, then the dehumidifier will start up into its full operation within 3 minutes. The signal is designed to pass successfully over a distance of about 100 meters, through an aluminum fence or steel-reinforced concrete wall. However, the individual conditions of a particular installation may be different. If there is no signal transmission, place the antenna in the lower (suction) air ducting.

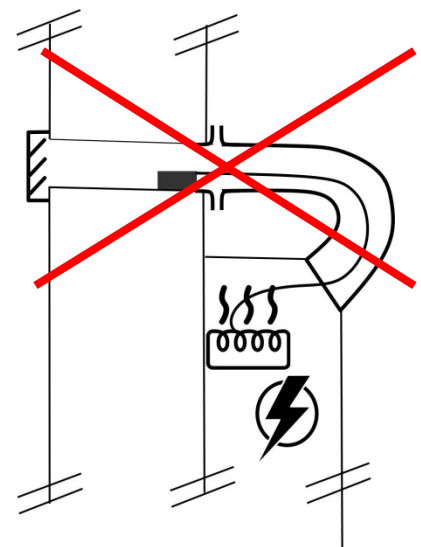

4.4 Humidity control by external wired humidistat EBERLE

If your device is equipped with an EBERLE wired remote humidity controller, pay attention to this section of the installation manual.



Wired humidistat EBERLE HYG6001



Wired humidistat and thermostat EBERLE

The dehumidifier can be equipped with a remote humidistat on request. In this case, the dehumidifier has two humidity controllers. One of them is a built-in mechanical humidistat inside the pool dehumidifier, the other is an external wired humidistat. The dehumidifier is controlled primarily by the remote humidistat, provided that the built-in humidity controller inside the dehumidifier is set to a higher desired humidity value than the remote humidistat.

If your dehumidifier is equipped with a hot water insert and/or a solenoid valve also, you must use a humidistat with an EBERLE HYG7001 thermostat to activate the dehumidifier's air heating function, or you must have an external thermostat connected.

4.5 Fan regulation

Under the inner cover of the device there is a two-position fan mode switch. In the first position, the fan runs even if the compressor of the device does not, it is a so-called **CONTINUOUS mode**. In the second position, the fan runs simultaneously with the compressor, it is a **PERIODICAL mode**. The continuous operation mode of the fan is more optimal, as the humidity sensor built into the device continuously senses the humidity, which achieves higher accuracy. At the same time, the continuous operation of the fan mixes the air in the room better. The fan control is set by the installation company according to the user's requirements. DRY800/1200 models are equipped with two speeds. In the case of continuous operation, the fan still runs at **full** speed. In the case of continuous operation while the compressor is switched off, the fan runs at **low** speed, which effectively mixes the air in the pool hall.

CONTINUOUS DUTY OF THE FAN

PERIODICAL DUTY OF THE FAN



4.6 Compressor regulation

The start of the compressor is delayed by 3 minutes due to its protection. Depending on the humidity and ambient temperature, this may take longer. If the compressor stops, it will start automatically after 3 minutes at the earliest. The user must not manipulate the setting element of this time protection. The task of time protection is to equalize the pressures of the refrigerant in the dehumidifier's system.



After a long period of inactivity, it is normal for the compressor to try to start 4-6 times before finally turning on. It also depends on the current air temperature. A lower ambient temperature (approx. 22°C) requires more attempts, a higher temperature (approx. 30°C) usually requires only 1 attempt.

5. INSTALLATION MANUAL



Please note that the screws and dowels supplied with the appliance may only be used on a solid concrete or a brick wall. Please check the base material and select suitable screws and dowels.



The appliance must be installed in accordance with national installation and wiring regulations!



The location of the device must be in accordance with the STN 33 2000-7-702 standard. It is recommended to place the device outside zones 0,1 and 2. When placing the device in zones 2 or 1, the STN must be observed.



It is necessary to place the device outside zones where cleaning with spraying water is expected. Connection to the electric network and protection must comply with relevant standards. The power supply of the device must be realized by a protective isolating transformer or protected by a residual current device with a rated residual breaking current not exceeding 30 mA when installed in rooms where water can be found.

5.1 Locating the device

ZONE 1, IPX4

**Pools that are not cleaned
by water jet**

at a distance of 1250 to 2000 mm from the edge of the pool
they must comply with STN and at least 300 mm from the floor.

ZONE 2, IPX2

**Pools that are not cleaned
by water jet**

at a distance of 2000 to 3500 mm from the edge of the pool must be in accordance with STN and is required min. 150 mm elevation above the floor due to sufficient airflow, installation of the device on the floor is prohibited.

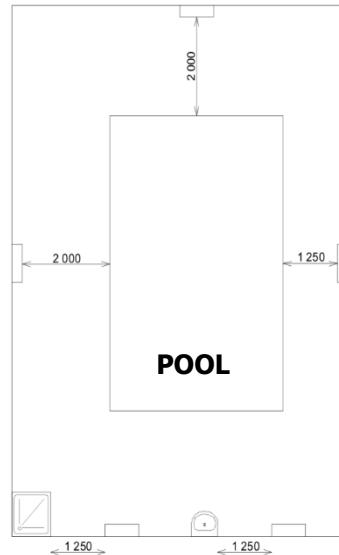

OUTSIDE ZONE

at a distance of less than or equal to 1250 mm from the edge of the pool, the lower edge of the device must be at a height of 2500 mm from the surface of the pool, if it is recessed under the floor or from the floor.

min. 1250 mm (i.e. out of reach) from the side edge of the shower enclosure, cannot be above the shower enclosure.

min. 1250 mm (i.e. out of reach) from the side edge of the sink at a height of min. 1200 mm from the floor, cannot be above the sink.

OUTSIDE ZONE

at a distance of min. 1500 mm from the vertical plane around the jumping platforms, jumping boards and starting blocks and 2500 mm above the highest surface on which people are expected to be present.

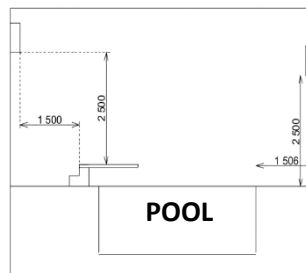

OUTSIDE ZONE

if the unit is at a distance less than or equal to 1250 mm horizontally from the edge of the pool, then it must be lifted 2500 mm from the surface of the pool, if it is recessed under the floor and from the floor.

MICROWELL DRY 800/1200 WAVE are designed to be installed directly in the pool hall. All models are protected by electrical protection class IP44.

1. In order to be as efficient as possible, the appliance must be installed as high as possible but not completely below the ceiling. Leave min. 200mm free space above the device. Due to maintenance, it is also necessary to leave free space of min. 200 mm on the sides of the device.

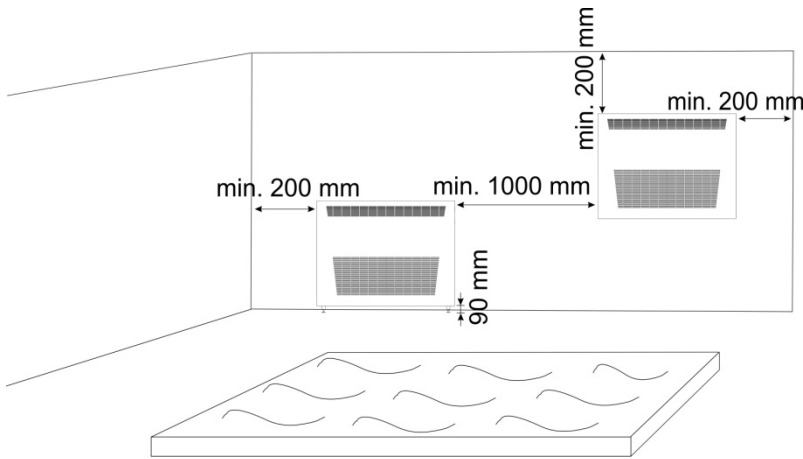

2. It is not advisable to mount the dehumidifier close to heating elements, as the dehumidifier could suck in heated air and this could delay its regulation. Also, placement above, for example, a radiator can cause the device to overheat, malfunction, or be damaged. It is also not advisable to place the dehumidifier near open windows, as it could suck in outside air and it could also delay its regulation. The suction of outside air causes the moisture from the pool hall not to be resolved and thus to accumulate in the pool hall.

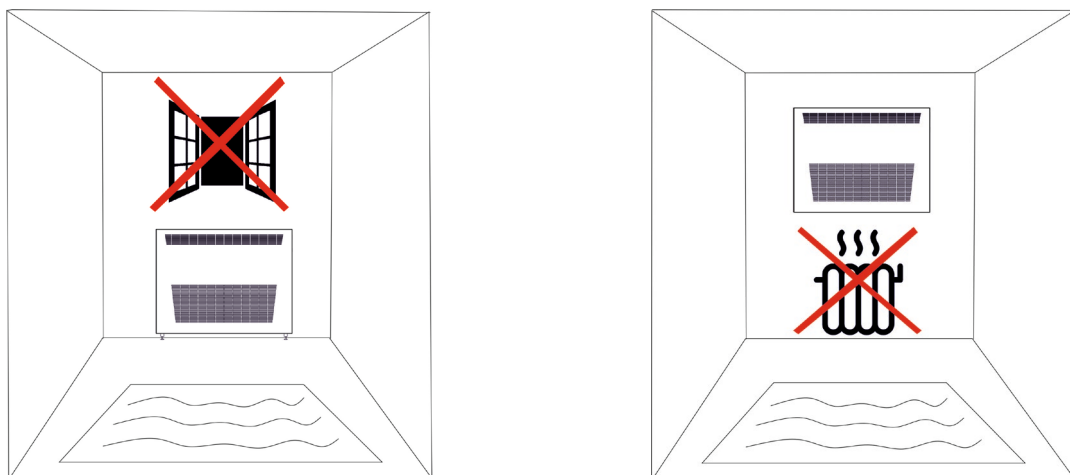

3. If two dehumidifiers are used in one room, it is recommended to install the devices further apart to ensure correct air flow in the pool hall and to achieve the desired humidity control effect. Installation too close to each other can cause dry air to circulate between the devices. This can result in excessive humidity in part of the pool hall. We also recommend maintaining a distance of at least 1 meters between the devices for future installation and service.

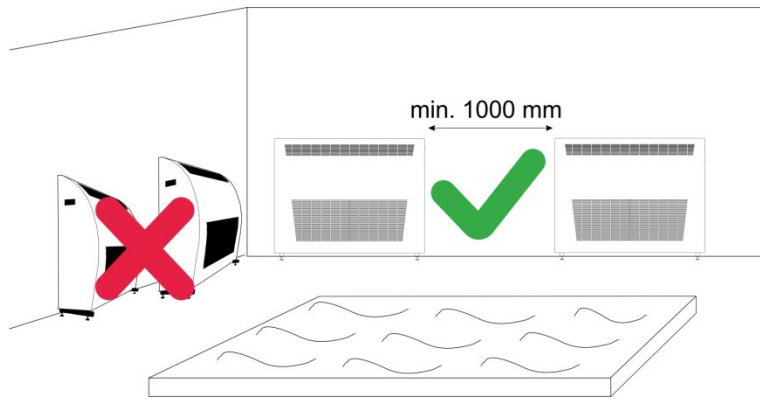

4. Always install the dehumidifier so that it can dehumidify pool air. In case of a structured pool hall, or a separate part – the placement of a dehumidifier is not suitable as the air flow will not be sufficient, thus the desired dehumidification effect may not be achieved.

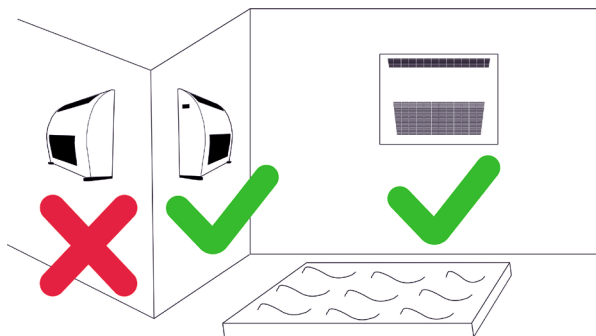

5.2 Installation of device

1. Cut the fixing tapes

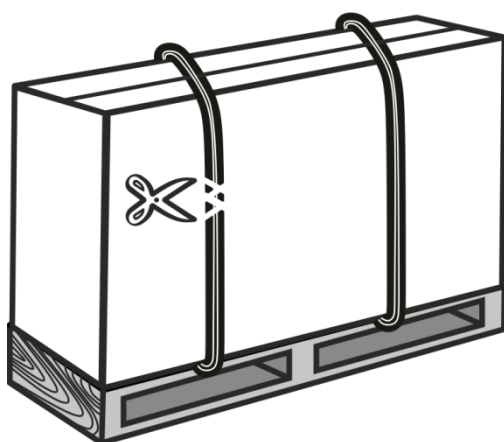

2. Slide out the cardboard box

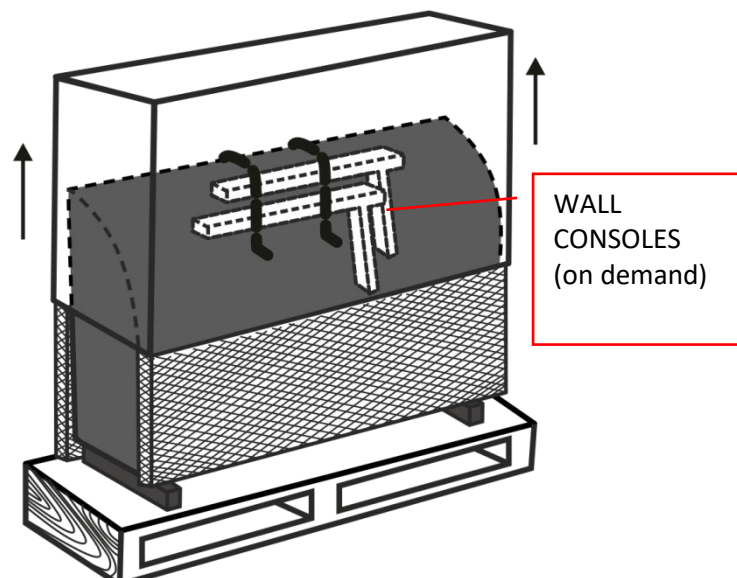

3. Remove the 4 M8 screws that secure the dehumidifier to the pallet.

WARNING! Do not unscrew the M6 screws. After removing these screws, there is risk of the device falling.

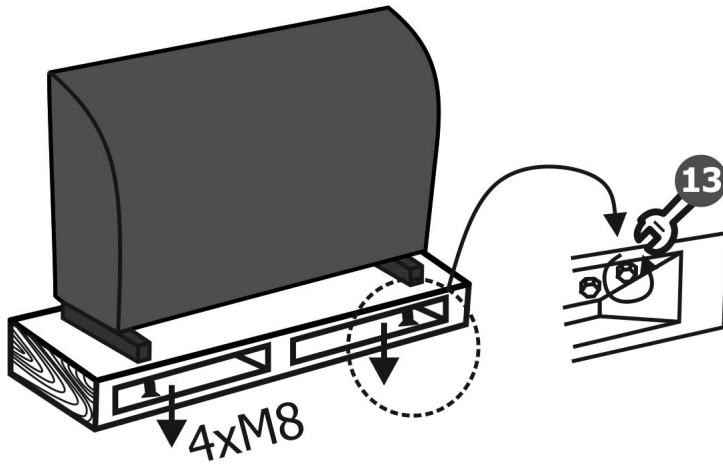

5.2.1 Floor installation

1. After removing 4 M8 screws, insert 4 rubber feet instead.

2. Floor installation is complete. Finally, attach the dehumidifier to the wall as shown below.

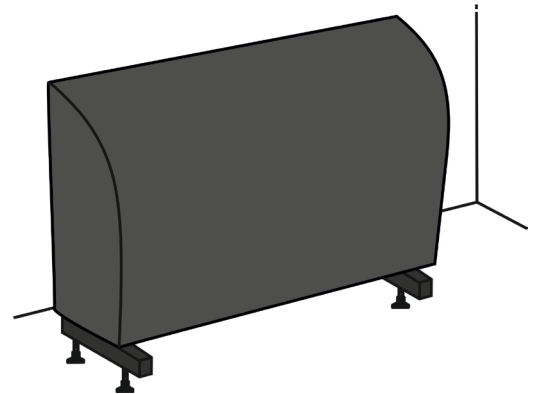
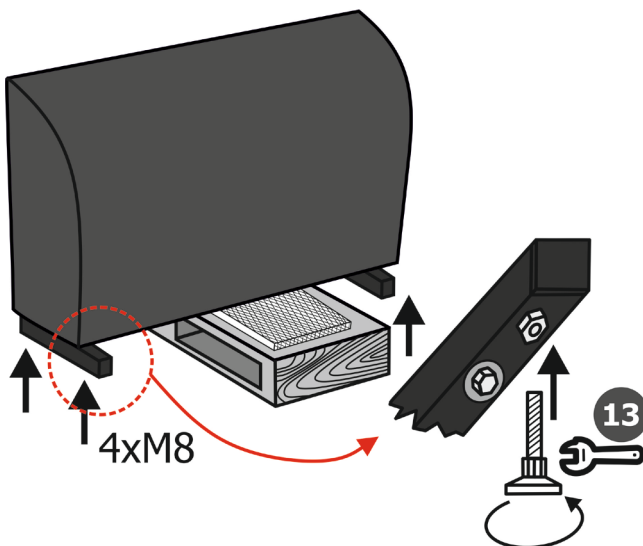

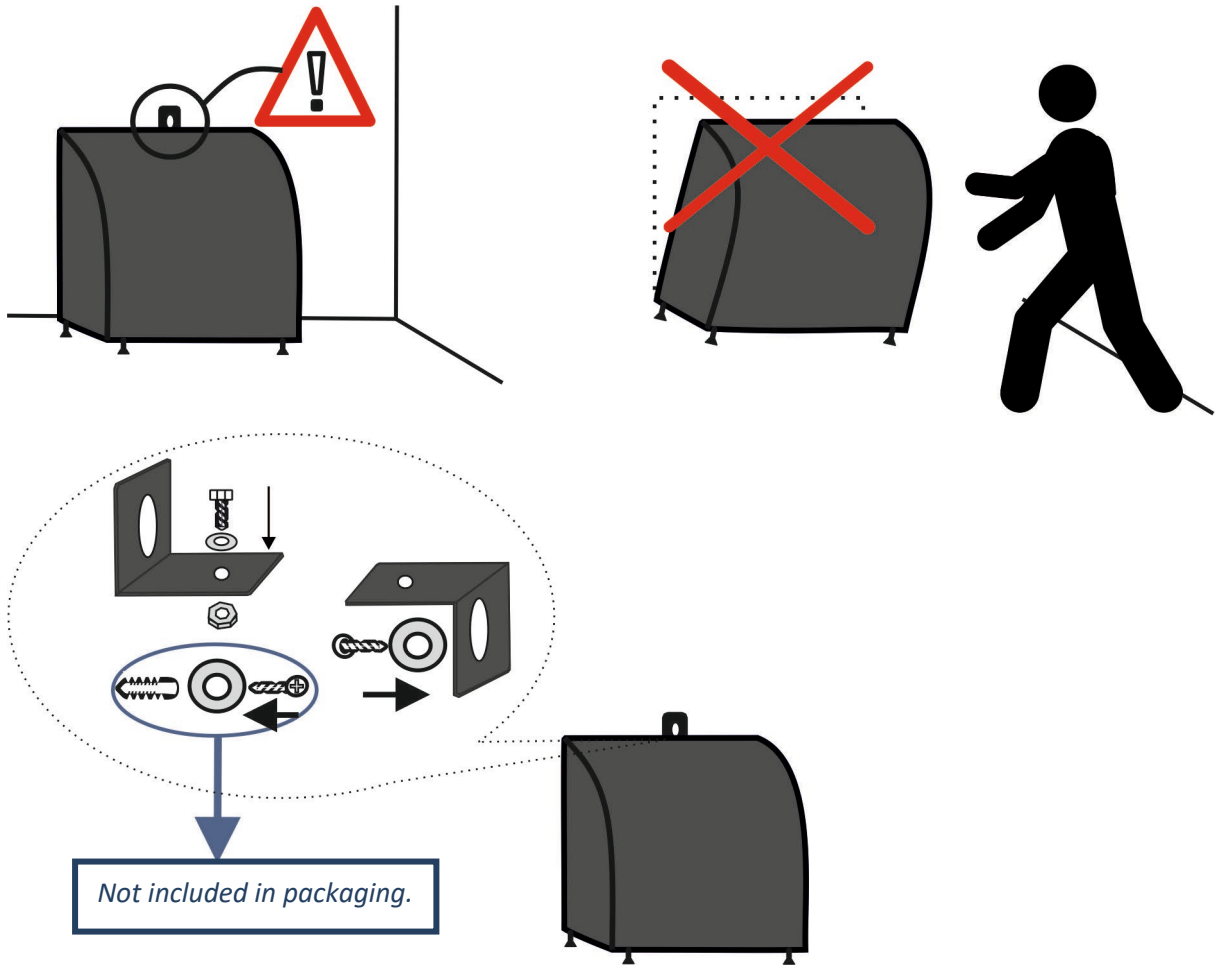

5.2.2 Wall installation - on demand

If the dehumidifier is being installed on a wall, it is necessary to order a set of brackets for wall mounting. This is used instead of the legs that come standard with the device. The set of brackets for wall mounting consists of:

6 pcs d 10 mm nylon dowels length 160 mm for anchoring in solid brick and concrete

6 pcs M8 dowel screws

4 pcs M6 screws for attaching the dehumidifier bottom through the brackets

Each bracket is attached to the wall with three screws through the holes in the bracket into the dowels on the wall. The brackets must be mounted at a distance from each other as shown in the figure below. After mounting the device on the brackets, the device at the bottom must be screwed to each bracket with two M6 screws.

Installation procedure:

Wall consoles should be mounted on the wall. Afterwards the unit should be placed on the wall consoles with its original feet. Do not remove the feet.

Be careful not to place the cover/unit on the floor without feet. There is a risk of scratching and damaging the cover.

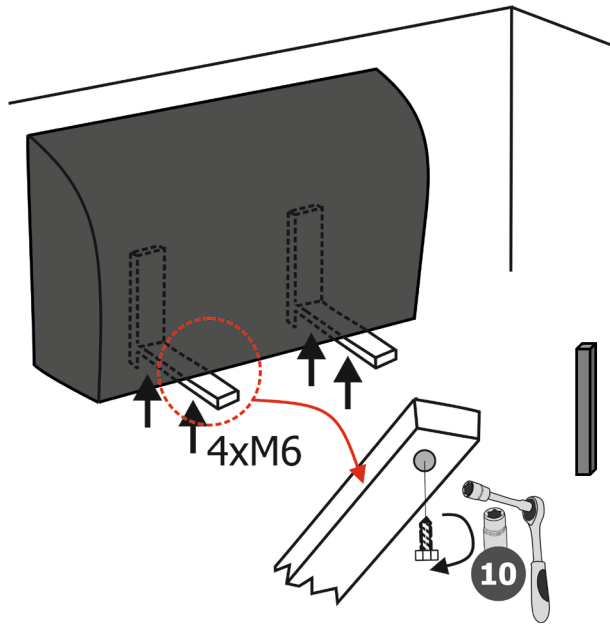

5.2.3 THROUGH-THE-WALL installation - on demand

Dehumidifiers are also easily adapted for installation behind a wall in a side room. Only two grilles are then visible in the pool hall area. In the version behind the wall, there are holes on the back plate of the dehumidifier for connecting pipe extensions. The extensions are supplied in a length for penetration through a wall 400 mm wide. On site, they are then shortened to measure by the pool hall.

SIDE VIEW

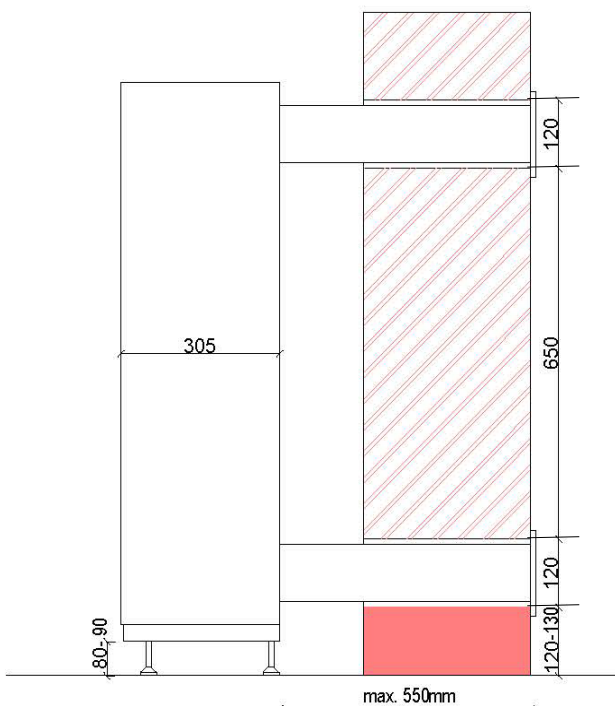

VIEW FROM THE POOL HALL

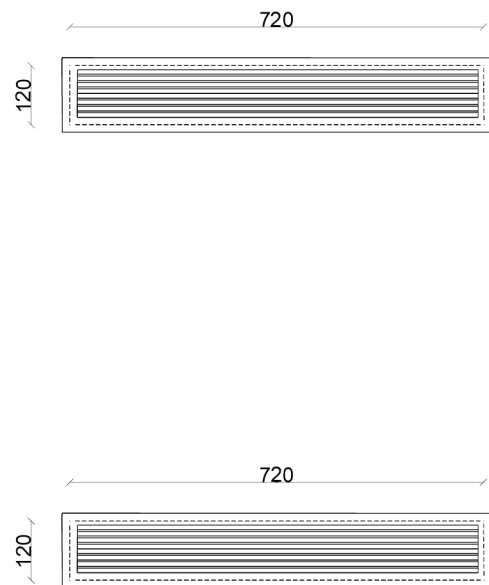

The dimensions of construction openings are annotated.

REAR VIEW - Intake and exhaust positions on the back of the dehumidifier and fresh air supply

Heating water supply to hot water
inserts on the right side/when viewed from the front

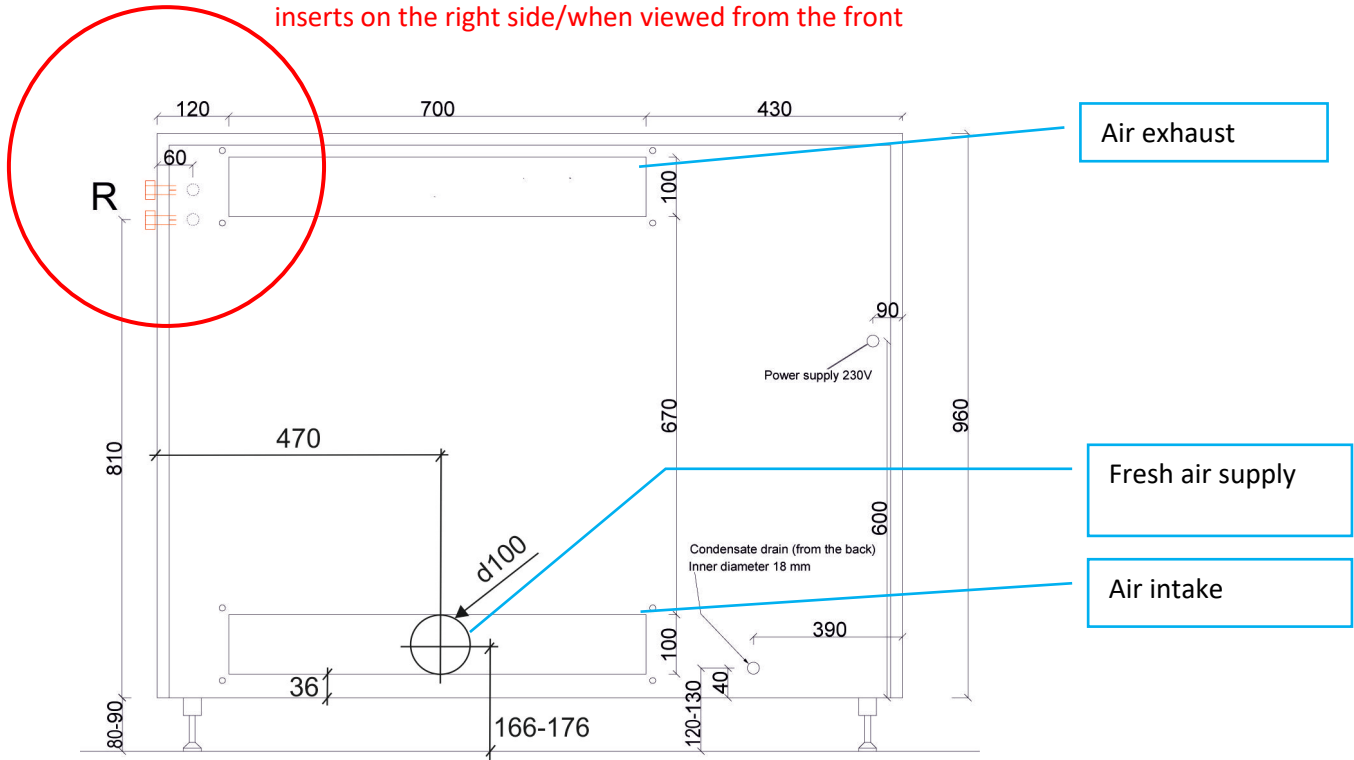

Heating water supply to hot water
inserts at the back of unit

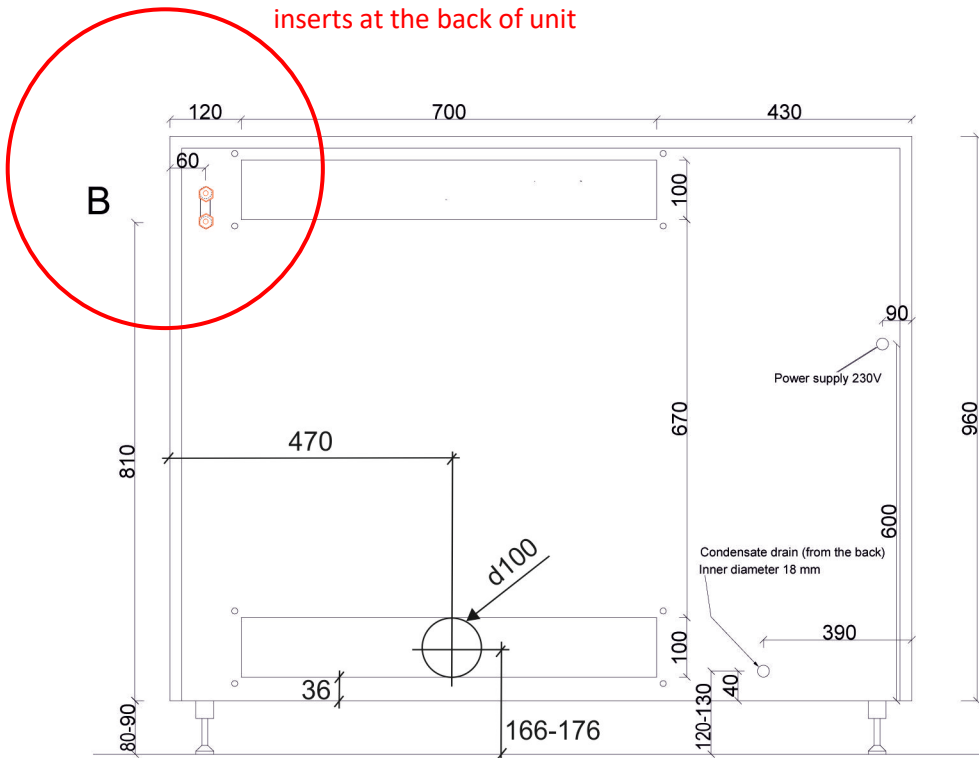

FRONT VIEW

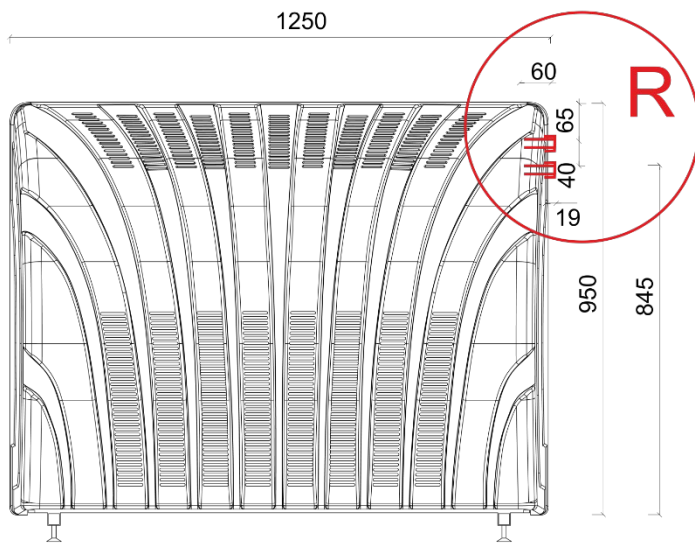

Heating water supply to hot water inserts on the right side of unit

SIDE VIEW

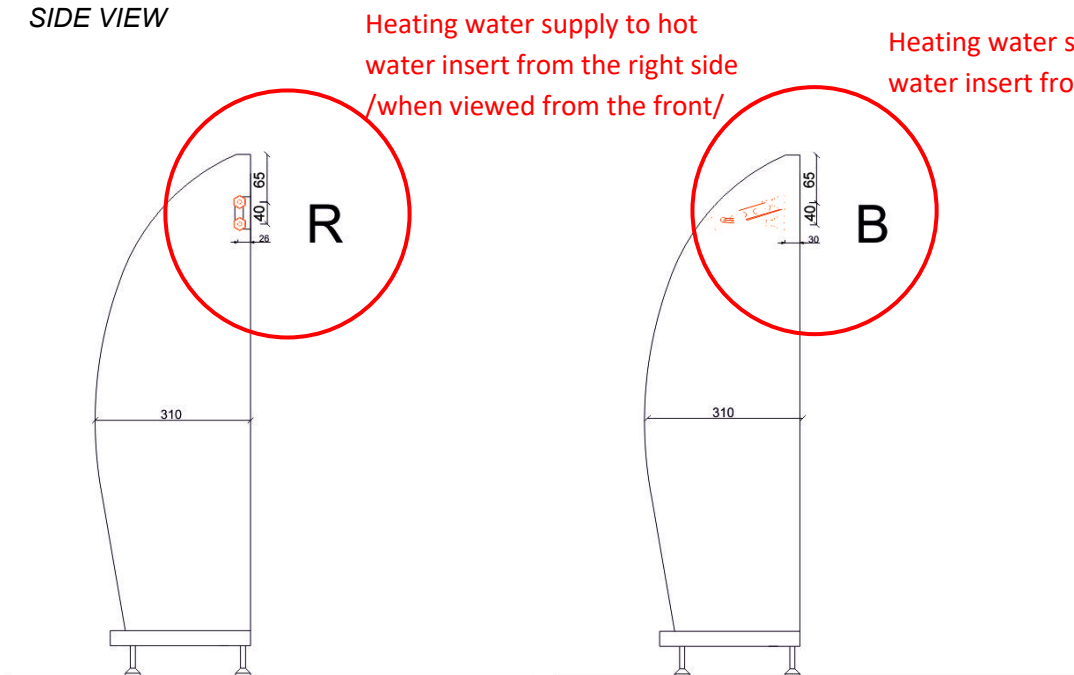

Heating water supply to hot water insert from the right side /when viewed from the front/

Heating water supply to hot water insert from the back

COVER REMOVAL

DRY800-1200 WAVE is designed to be installed in a pool hall without the necessity to remove the main chassis cover. The cover is typically removed only in the circumstance of a maintenance (such as cleaning) or service. When removing the cover please be gentle and mind that it is a one piece of plastic.

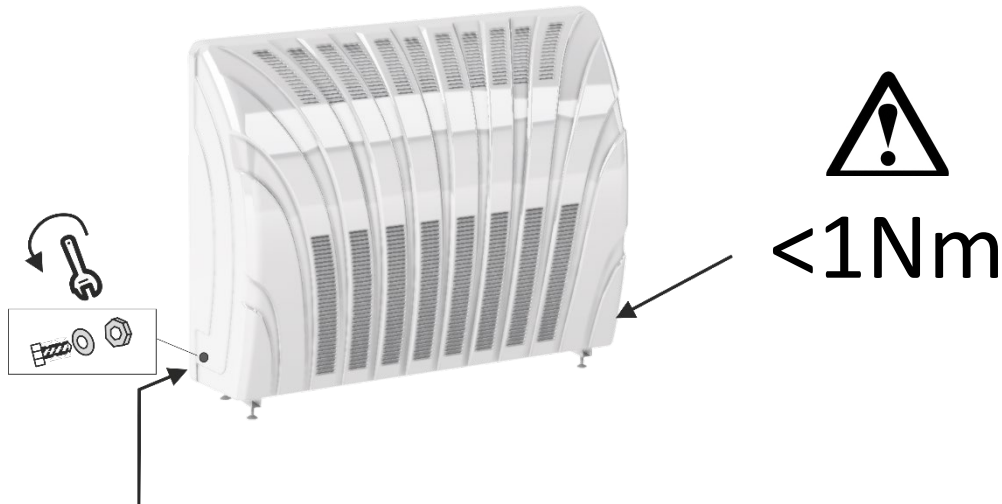

Lower the side cover caps, unscrew and remove the side cover screws.
When assembling the cover back please apply torque up to 1.5Nm.

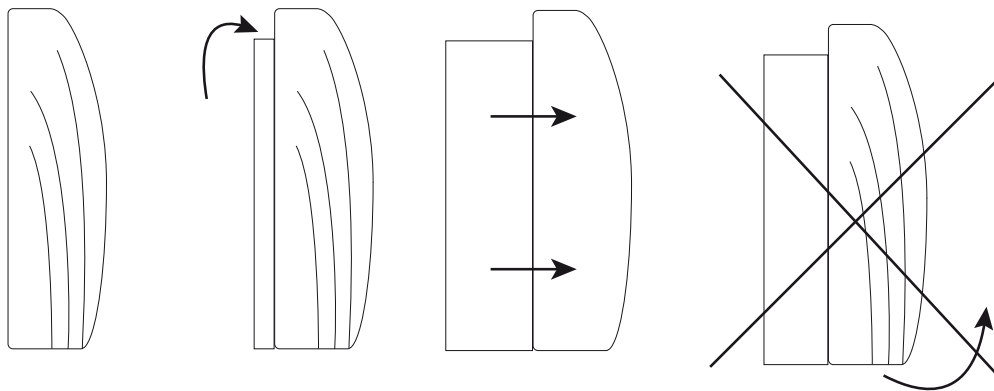

In order to dismount the Wave cover from the unit, lift it gently to overcome the back metal plate at the top. Then pull forward in waterlevel direction. Do not lift or push otherwise. The Wave cover may get damaged if you lift it from bottom upwards.

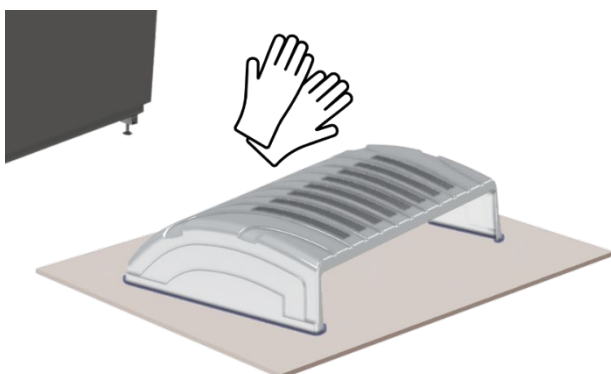

Place the cover sideways on a foam pad or cardboard so that you **do not scratch** the cover on the floor. Use soft gloves when handling the kit.

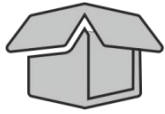

Take out the additional accessories packed in the cardboard box under the cover (wireless humidistat and thermostat DRY EASY 300, solenoid valve, heating insert).

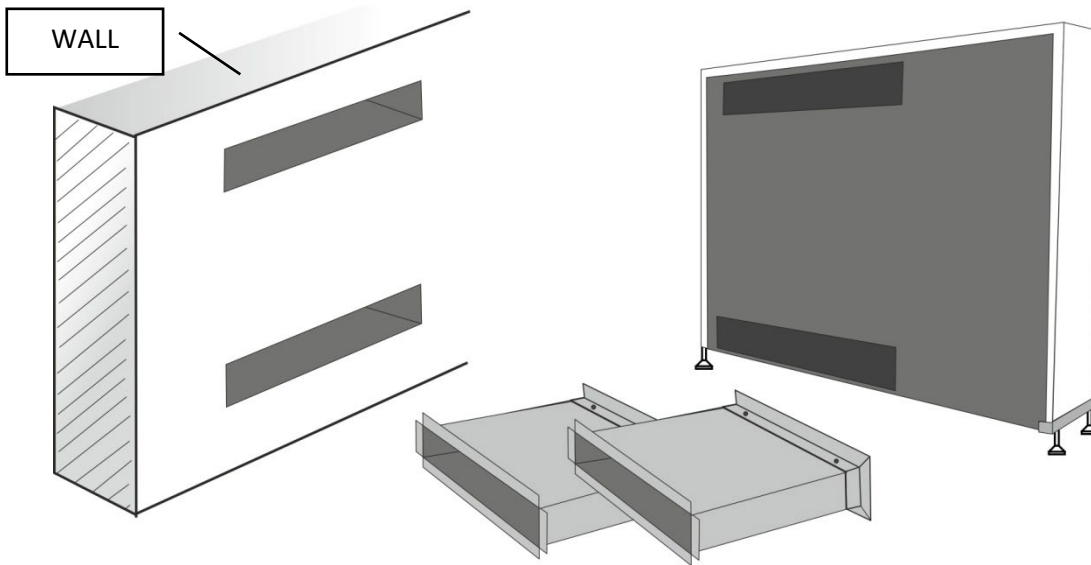

Prepare the holes in the wall, pipe fittings and dehumidifier for the installation site.

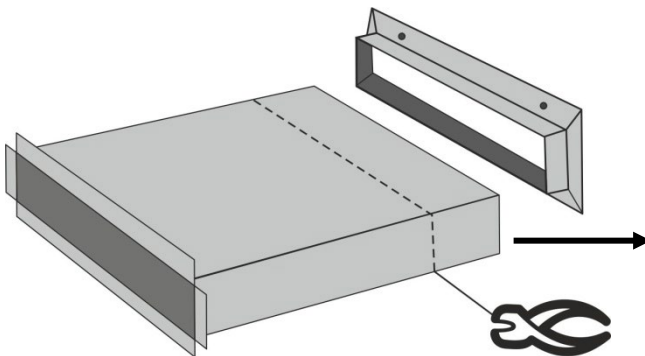

Remove the flange, cut the pipe as required.

Slide the dehumidifier against the wall to the pipe fittings, connect the electrical cable and the condensation hose.

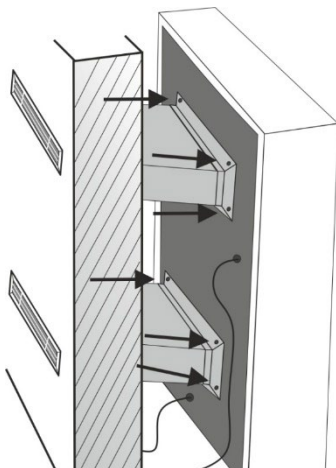

Slide the dehumidifier onto the pipe fittings and screw the pipe fittings onto the rear wall of the dehumidifier.

Fill the gap between the pipe fittings and the holes in the wall with PUR FOAM.

Replace the dehumidifier cover the same way you removed it.

Proper grill installation

When fitting the grilles, pay attention to the inclination of the slats and fit the grilles as shown below.

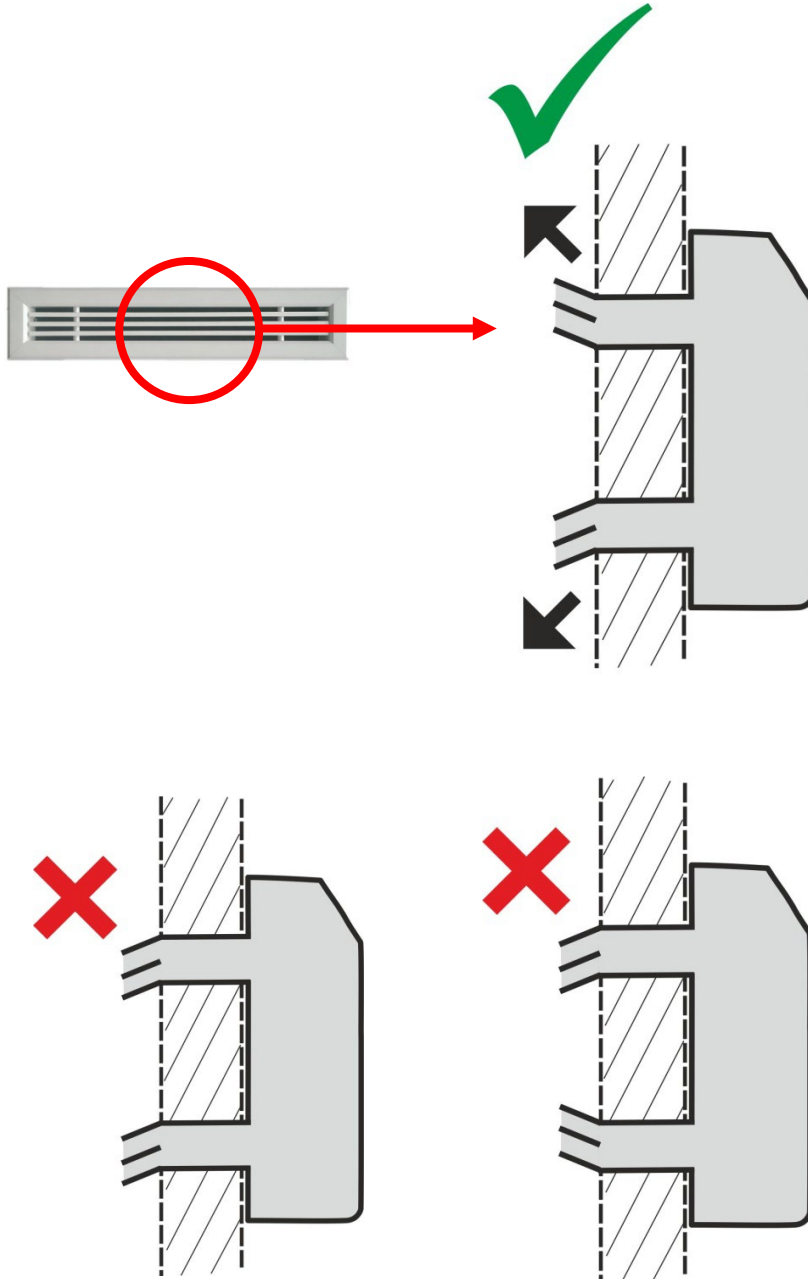

THROUGH THE WALL INSTALLATION WITH THE UNIT ON THE WALL

Your unit may have been ordered and manufactured as wall installation and through the wall. In this case it is advised to affix the straight air ducting on the unit from the back before placing the unit on the wall consoles. For the wall installation please refer to section 5.2.2. Wall installation – on demand.

Procedure how to affix the through the wall ducting described below.

1.

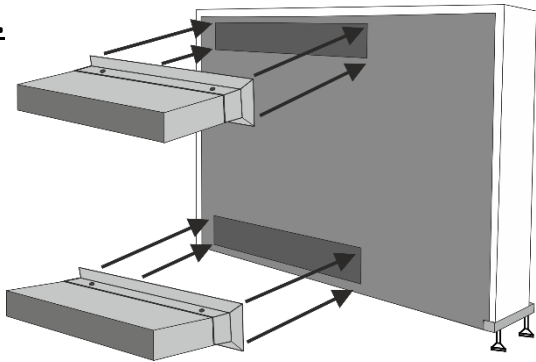

2.

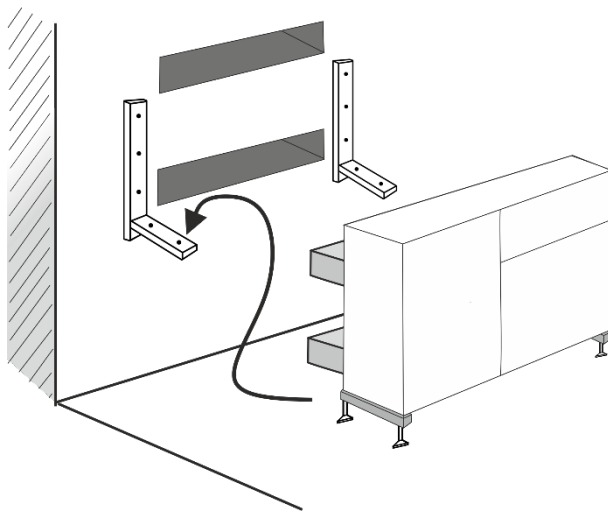

3.

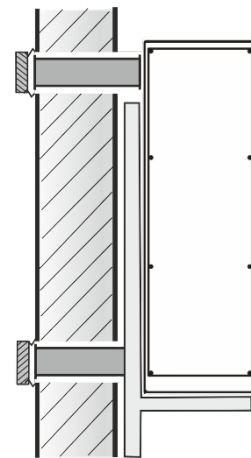

5.2.4 Compressor protection during transport

The compressor is protected during transport by plastic straps. This requires the size and weight of the compressor so that the equipment delivered to you is safe and fully functional. This protection must be removed before starting the dehumidifier (see pictures below). The process usually takes a few seconds. Please note that warranty conditions cannot be applied without removing the plastic tapes.



Img. 1: Illustration of the factory-fitted plastic strap.

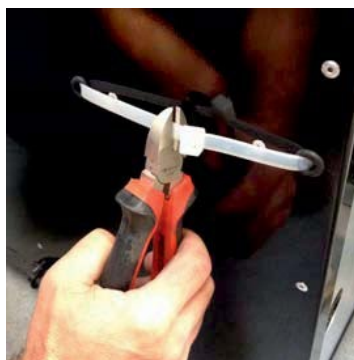

Img. 2: Cut the tape with a suitable tool.



Img. 3: Finally, pull the tape out of the device and remove it.

5.3 Condensate drain

When drying your pool hall, your dehumidifier will condense the water that is fed into its internal collection tray. Without active (free) condensate drainage, the dehumidification process will not work. Condensation water is drained from the dehumidifier by gravity (downwards). The condensing tray has the correct slope when the dehumidifier is mounted horizontally (using a spirit level). Condensed water must be drained through a siphon to the sewer or to the outside environment. Please do not place the drain hose upwards (against gravity), as this may cause the appliance to be unable to drain water condensate. This in turn will cause water to leak from under the unit cover and may lead to unit failure, damage, or failure. It can also cause the floor to get wet, creating the risk of injury and damage to health from unwanted slipperiness. The manufacturer, distributor or dealer is not liable for such damages. We recommend using the **HL 138** concealed siphon designed for air conditioning units in the condensate drain. This must be located min. 20 cm below the condensate outlet from the dehumidifier. The pictures below show more.



Warning:

Condensed water from the dehumidifier must not be collected in the collecting container tank! Condensed water from the dehumidifier must not be returned to the pool!

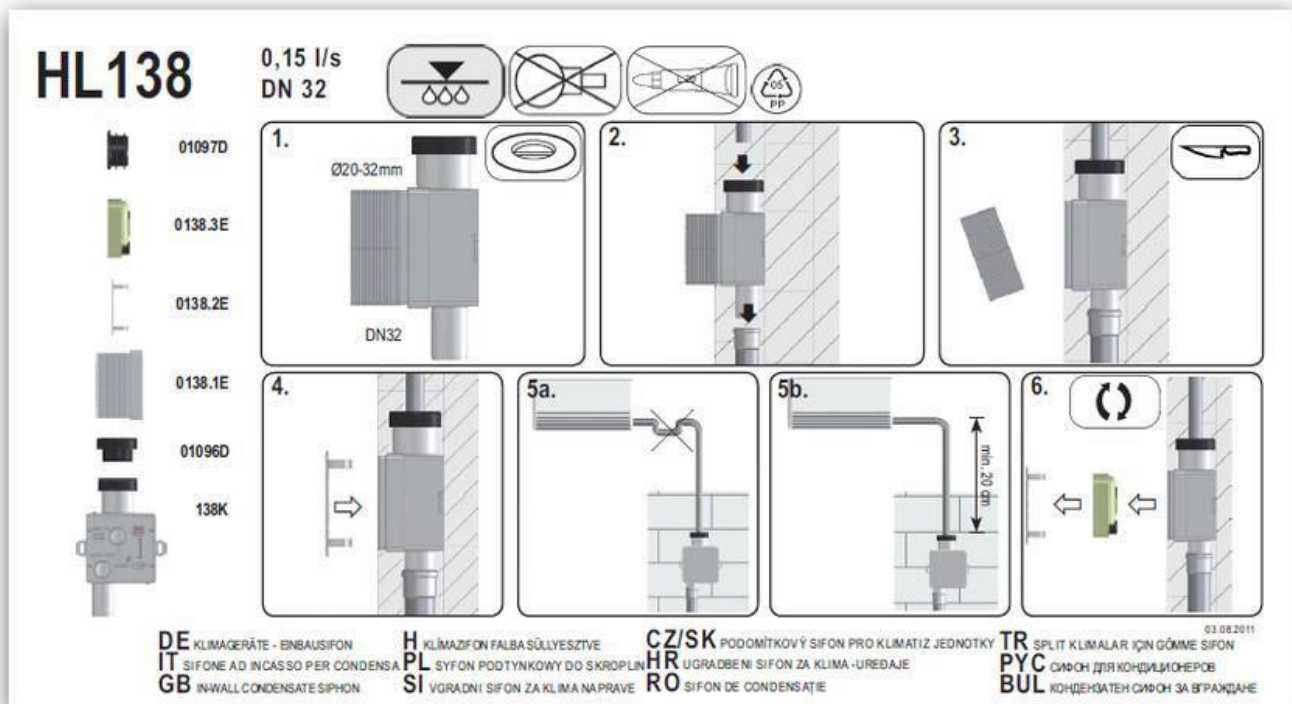

Proper installation of condense hose

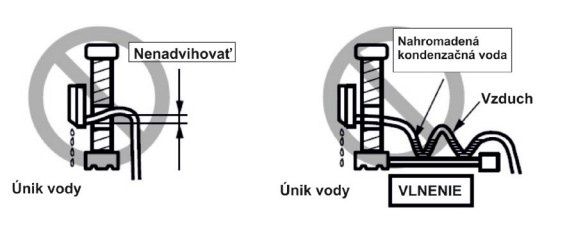

Improper installation of condense hose

CONDENSATE DRAIN

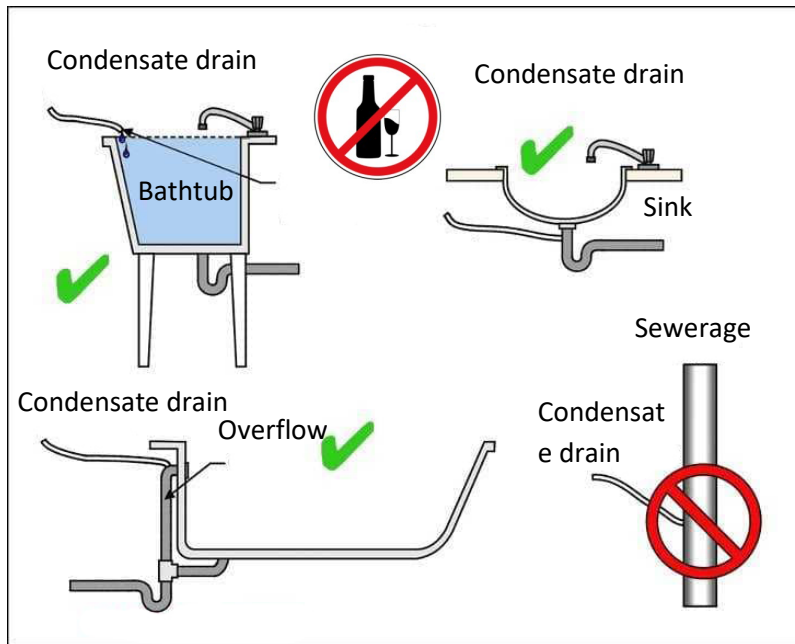

5.4 Main power supply connection

5.4.1 Main electrical connection for fixed cable in wall

As standard, the dehumidifiers are connected to a fixed cable in the wall. Connecting the device to an el. network must comply with the relevant security standards. Connection requirements are: Power supply: **220-240 V / 50 Hz / 1f**. Fuse: **16A (DRY 800/1200)** with residual current device (**RCD**) with a rated residual current not exceeding 30 mA. The main switch of the device must be located outside the pool hall. The main switch of the appliance must be bipolar with the switch of the L and N wires. The appliance must be placed on a solid surface to disconnect the appliance from the mains. The distance between the contacts, when switched off, must be at least 3 mm for all poles.



The appliance must be connected to the mains by a certified electrician.



Mind all electrical safety precautions.

The mains terminal block is located in this black box

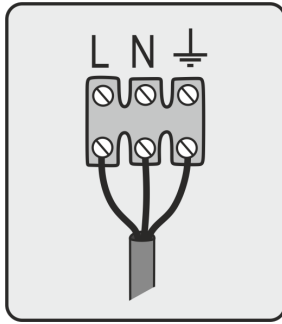

Standard terminal block -
L, N, ground

In order to connect the DRY800-1200Wave swimming pool dehumidifier model to the mains you need to access the plastic terminal box located at the back of the unit. The plastic box has a water proof rating of IP54 and is made of ABS fire retardant material. The plastic box is affixed on the back metal plate of the dehumidifier with a magnet. You can adjust the position of the box according to your needs. For disassembly when the dehumidifier is installed already on the wall or floor (very close to wall) you can easily remove the box from the back. Do not leave the plastic box hanging freely! Always affix the plastic box on the back metal plate using built-in magnet.

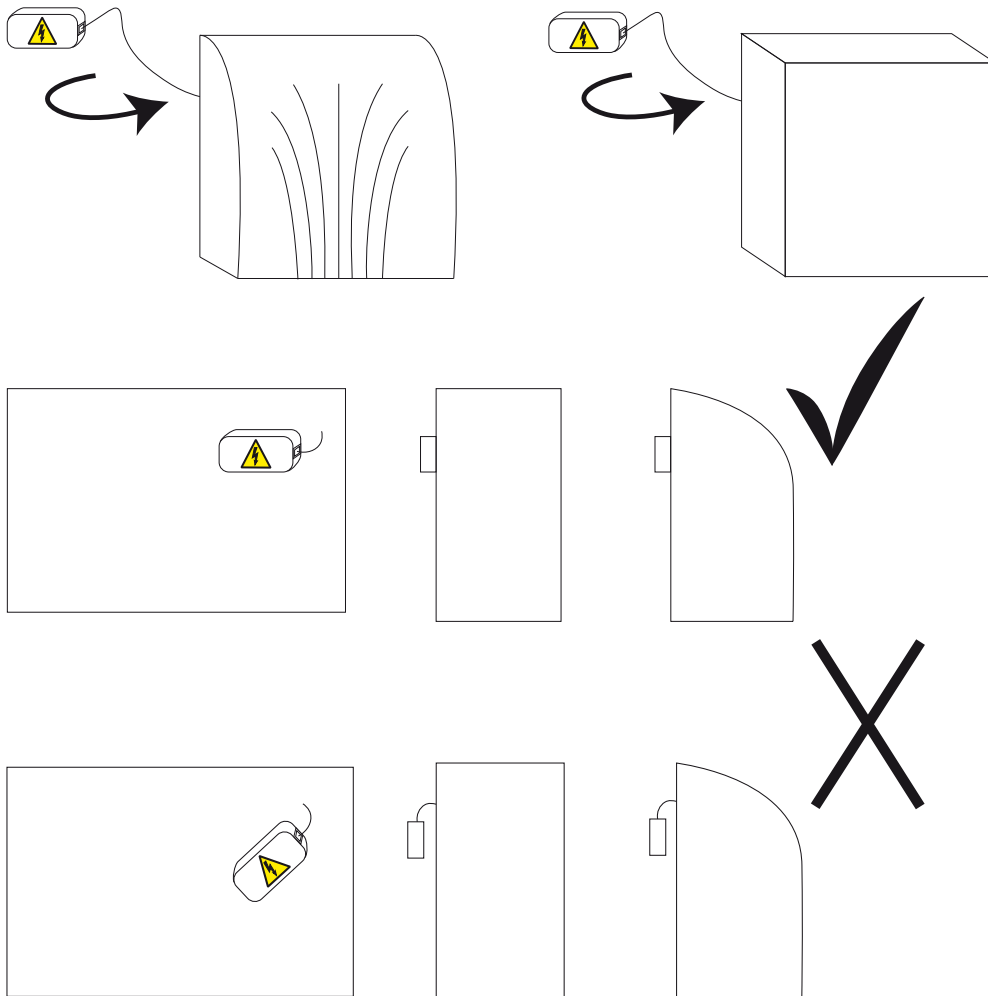

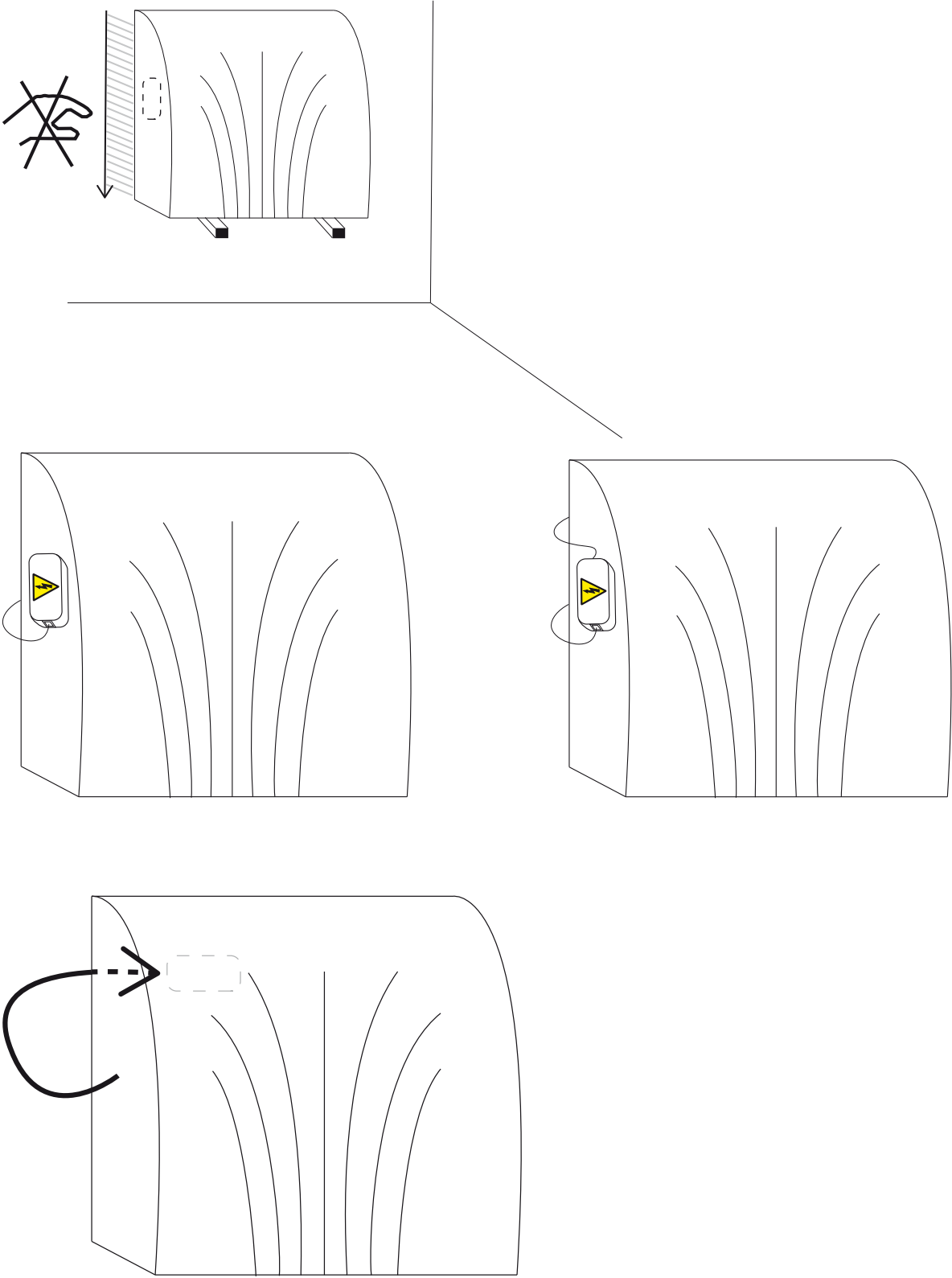

When connecting, please exclusively and only use built-in cable joint connector. This will ensure necessary water proof rating.

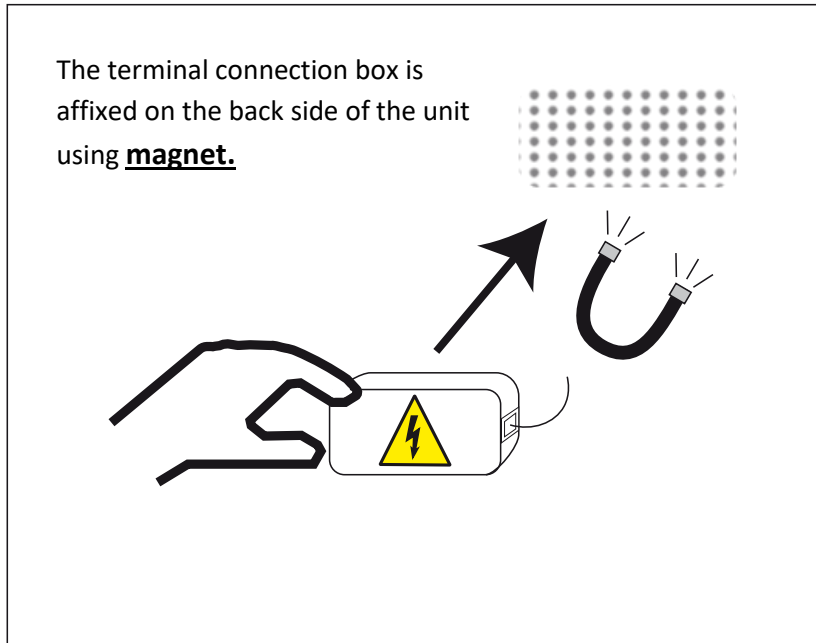

Always firmly close the Main electrical connection box. This will ensure necessary water proof rating.

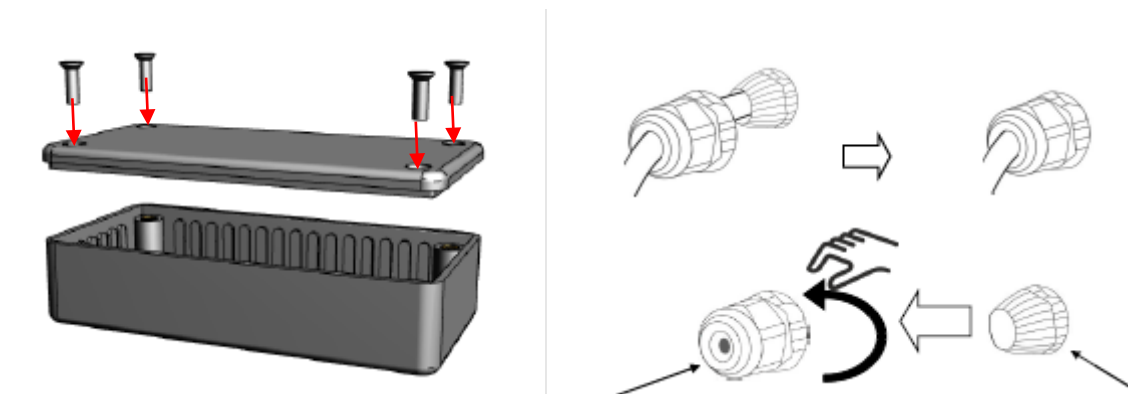

Always prefabricated wire enclosures. This will keep the necessary water rating of the terminal box.

Main power supply		
Dehumidifier type	El. cable	El. insulation
DRY 800	CYSY 3x 2,5 mm ²	16 A type C
DRY 1200	CYSY 3x 2,5 mm ²	20 A type C

El. connection of a potential-free contact for a cooperating hot water heating system		
Dehumidifier type	El. cable	Power supply
DRY 800/1200	CYSY 2x 1,5 mm ²	via contactor

Electric heating element connection		
Dehumidifier type	El. cable	El. insulation
DRY 800/1200	CYSY 3x 2,5 mm ²	16A
El. connection of wire humidistat and thermostat		

Model	El. cable
HYG6001	CYSY 4x 1,0 mm ²
HYG7001	CYSY 5x 1,0 mm ²

5.4.2 El. connection of external humidistat and thermostat

The connection of the EBERLE HYG6001 (HYG7001) cable remote humidistat is made at the installation site. The manufacturer does not supply the connecting cable.

EBERLE HYG6001 connection for DRY 800/1200

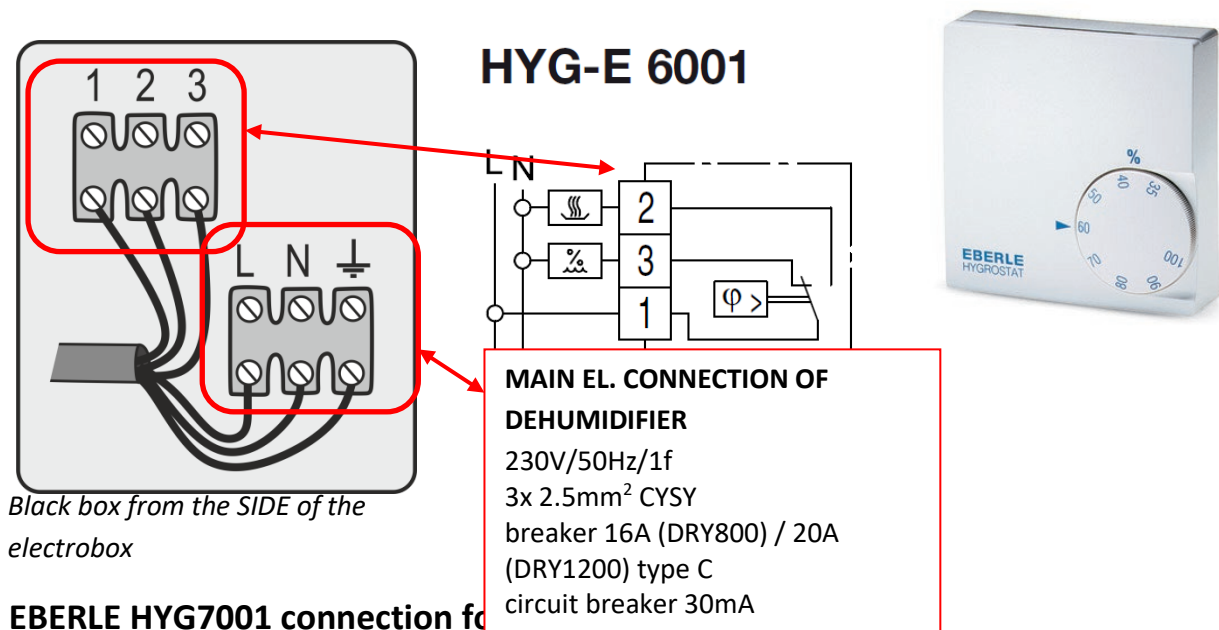

EBERLE HYG7001 connection for

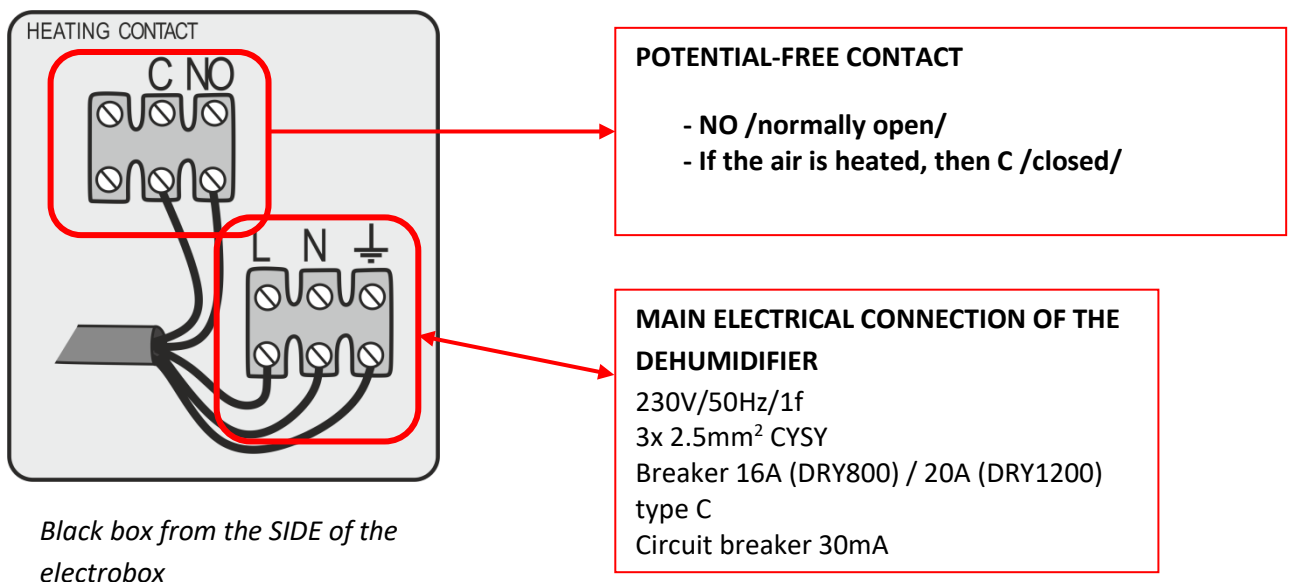

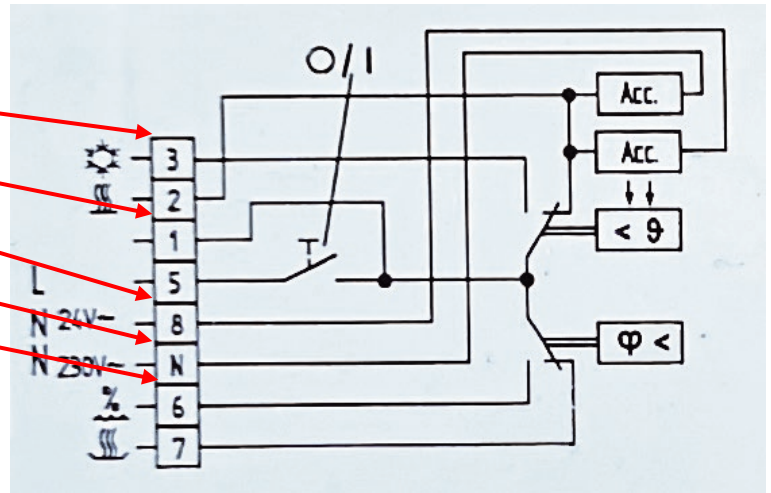
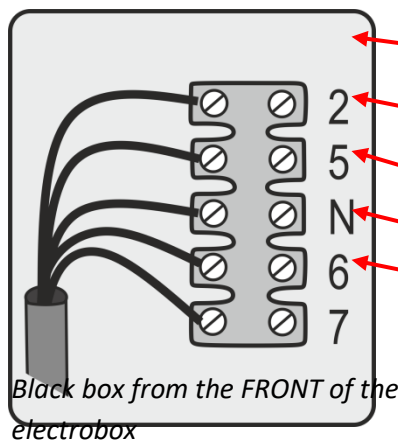

Electric heating element connection for DRY 800/1200

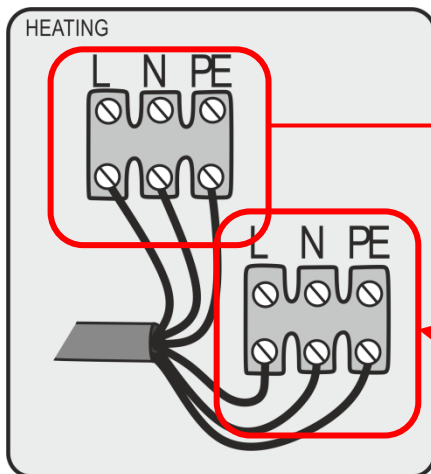

Black box from the SIDE of the electrobox

EL. HEATING POWER SUPPLY

230V/50Hz/1f
Kábel: 3x2.5mm² CYSY
Príkón: 2.5kW
Istič: 16A

MAIN ELECTRICAL CONNECTION OF THE DEHUMIDIFIER

230V/50Hz/1f
Cable: 3x 2.5mm² CYSY
Breaker: 16A (DRY800) / 20A (DRY1200)
type C
Circuit breaker: 30mA



The functions and operation of the remote humidistat are described in a separate enclosed manual.

5.5 LPHW hot water insert for additional heating – on demand

The LPHW heating element is only available on request. The connection of the LPHW hot water insert is made similarly to the connection of the radiator. A control valve is connected at the inlet and a shut-off valve with a screw connection at the return. These are supplied by the heating supplier.



Image: Solenoid valve with coil - used in **LPHW with regulation**; Connecting thread ½" inner

Recommendation: Install valves in front of the dehumidifier to disconnect the hot water insert from the appliance; Connecting thread ½" inner

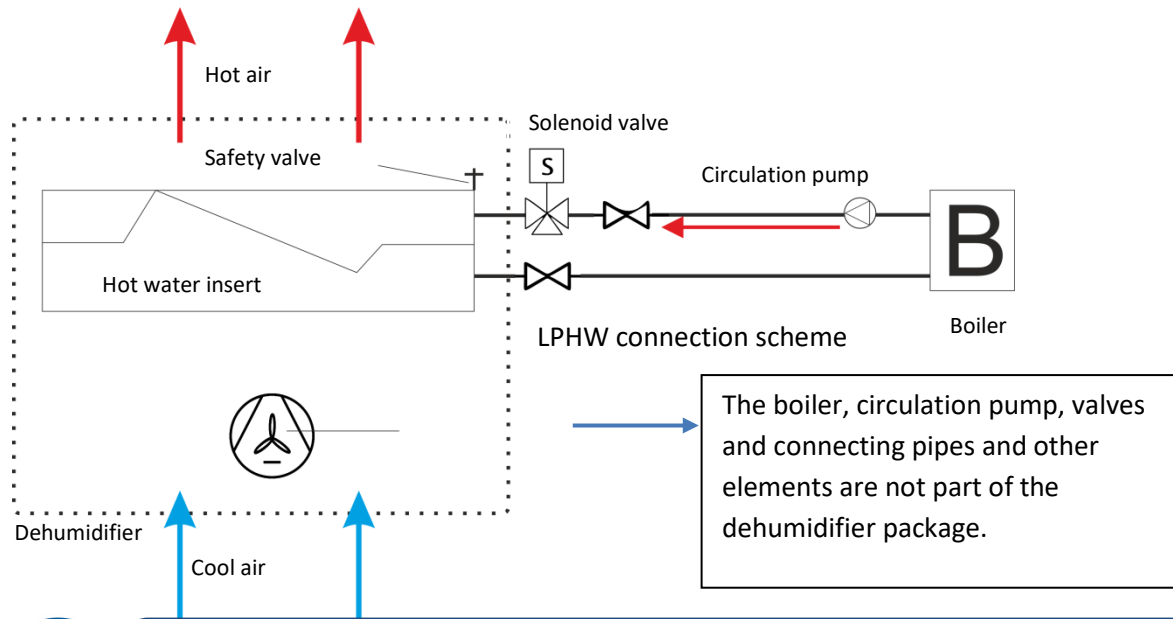

Please note that DRY 800/1200 is only equipped with a thermostat and a potential-free heating contact by standard if heating coil is selected and either wireless control DRY EASY300 or wired EBERLE HYG7001.

If your dehumidifier is equipped with a hot water insert and/or a solenoid valve, you must use a MICROWELL DRY EASY300 wireless humidistat and a thermostat with an EBERLE HYG7001 thermostat to activate the air heating function with a dehumidifier, or you must have an external thermostat connected. The reason is that the built-in mechanical humidistat or cable remote humidistat EBERLE HYG6001 does not have a thermostat function. An external thermostat is not included in the package of this product.

If your dehumidifier is equipped with a hot water insert and your dehumidifier is designed without a remote wireless humidistat with a thermostat, there is a risk of the dehumidifier overheating. Overheating can occur if hot water flows into the LPHW hot water insert even when the dehumidifier dehumidification is not running (fan off). Under normal circumstances, a remote humidistat with a DRY EASY300 thermostat and an original solenoid valve regulates the water supply automatically, effectively preventing the dehumidifier from overheating. It is therefore necessary to use a thermostat to control the heating in the appliance. Neither the manufacturer nor the distributor is liable for damages resulting from non-compliance with the above instructions.

Parameters of the solenoid valve:

- dimension DN 12,
- operating pressure PN 10,
- threaded connection,
- control: coil
- 230V (D-233),
- material: brass,
- controlled directly,
- type: 8253 12D 1 12 2 1 230V AC

No.	Item	Material
1	Safety nut	Galvanized steel
2	Washer	Galvanized steel
3	Coil	PBT + 30% G.F
4	Piping	Stainless steel AISI 430
5	Seal	FPM
6	Screw	Stainless steel
7	Cover	Brass CW 617 N
8	Spring	Steel
9	Ring	Stainless steel
10	Piston	Stainless steel
11	Spring	Steel
12	Support	Stainless steel
13	Insulation	NBR
14	Spring	Steel
15	Cover	Stainless steel
16	Membrane	NBR
17	Cover	Stainless steel
18	Body	Brass CW 617 N

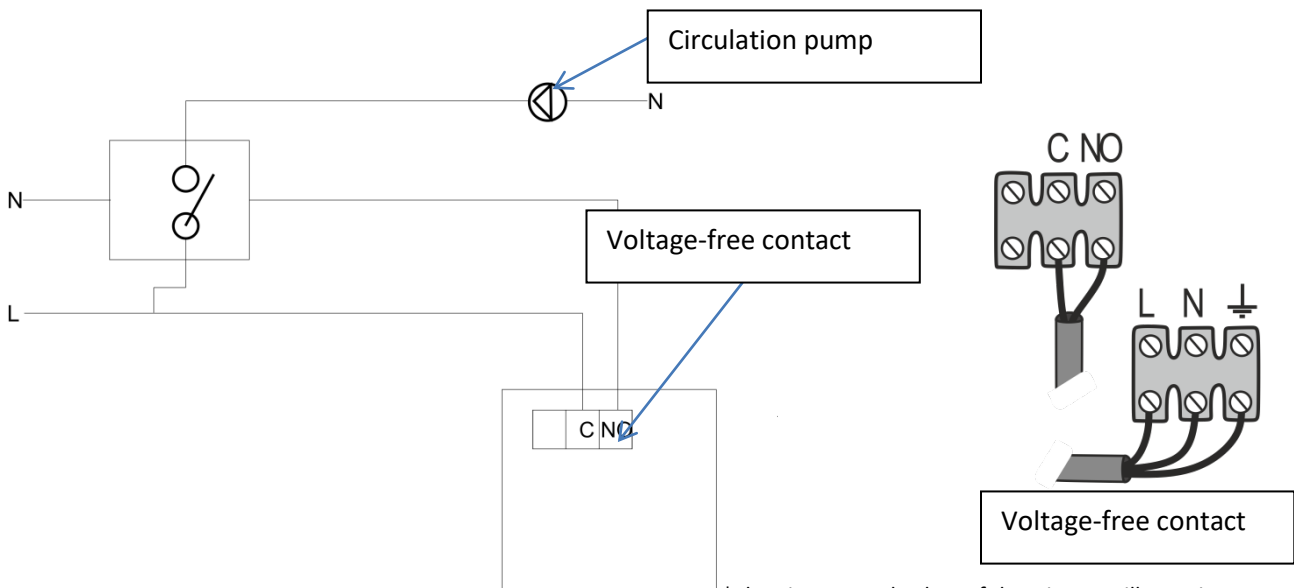
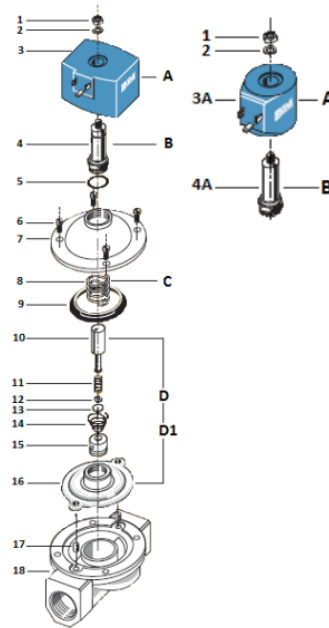

The dehumidifier can be equipped with a solenoid valve on request. When used in combination with a hot water insert, it has a similar function to the fan coil, i. the fan works independently with the compressor (humidistat) and independently with the LPHW hot water insert (thermostat).

Heat output of heating element LPHW (W) DRY800/1200	
90/70/30°C	7000
80/60/30°C	5880
70/50/30°C	4690
55/45/30°C	3010
45/35/30°C	1407



It is recommended to insert a shut-off valve between the LPHW hot water insert and the heating source. This will allow it to be quickly disconnected from the heating system in the event of a fault in the heating system and maintenance of the system or dehumidifier.

Water flow (l/min)	6
Pressure drop (kPa)	24.1
Connecting thread	½" inner

5.6 Electric heating

On demand, your pool dehumidifier can be equipped with an electric heater. It consists of a durable stainless steel tube in aluminium heat exchanger. Capacity 2,5 kW for DRY800/1200. The electric heater has a separate power connection, which is located in the black box the dehumidifier connection to the power supply located in the dehumidifier electrical box.

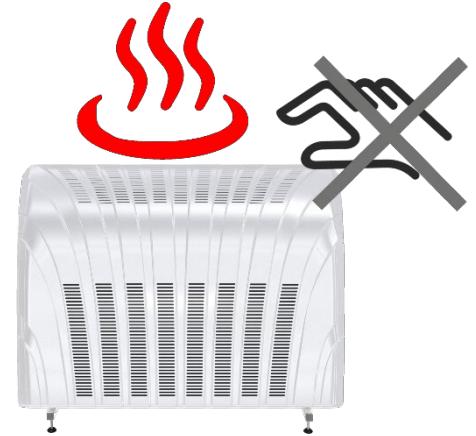

The electric heater is equipped with two safety switches.

The electric heating is switched on and off according to the set required air temperature on the dehumidifier controller / built-in or wireless DRY EASY 300 /.

Please note that the outer cover of the dehumidifier is made of plastic (acryl) continuously resistant to a temperature of 80°C, softens at temperature of 100°C. In the upper part of this cover during electric heating, its temperature can rise up to 65°C (at an air temperature of 35°C). It is therefore forbidden to touch the cover at the top of the dehumidifier during operation of the heater. It is also forbidden for children to play with or with the dehumidifier. Please note that children should be supervised by an adult at all times in the room where the dehumidifier is installed.

El. connection of hot water heating element		
El. heating element – input	El. cable	El. insulation
2,5 kW	CYSY 3 x 2,5 mm ²	16 A (please use separate circuit breaker from the one used for the unit itself)

The device can be equipped with an IP44 power cable. Use an IP44 socket. A socket with a lower degree of protection than IP44 does not guarantee the protection of the dehumidifier.

When using an IP44 power cord and outlet:

- Do not place the plug and socket in humid places or in places with leaking or dripping water.
- Do not place any objects on the cable, do not use the cable for any purpose other than to power the device.
- Place the cable away from other appliances such as radiators, motors, rotors, etc.
- Do not use a dehumidifier if the cord shows signs of damage.
- Always observe the electrical requirements for installation / e.g. breaker.
- Children and unauthorized persons must not manipulate the cable or plug.

5.7 Air filter – on demand

Your dehumidifier can be equipped with an air filter on request. The air filter traps dust and other mechanical particles and prevents them from entering the fins of aluminum heat exchangers. Although the air filter contributes to the cleanliness of the dehumidifier, it does not have the function of an antibacterial HEPA filter.

The operation of your dehumidifier is highly dependent on the continuous supply of air from the environment. It is therefore important to keep the air filter clean. Please read the simple steps below to clean the filter. If the

filter is clogged with dirt, it creates a barrier to air supply. The manufacturer recommends cleaning at least once a month. The manufacturer, distributor and dealer are not responsible for damage or malfunction of the device resulting from insufficient cleaning of the air filter.

When replacing the filter, it is necessary to disconnect the dehumidifier from the el. and the device must be switched off.



1. Remove the dehumidifier cover. Pay close attention to the controller connectors, such as cables and antennas.

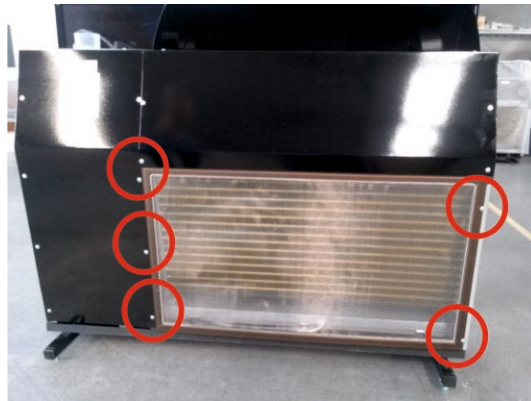

2. Unscrew the 2 screws on the right side and easily loosen the 3 screws on the left side.



3. Pull out the filter and slide it to the bottom left.

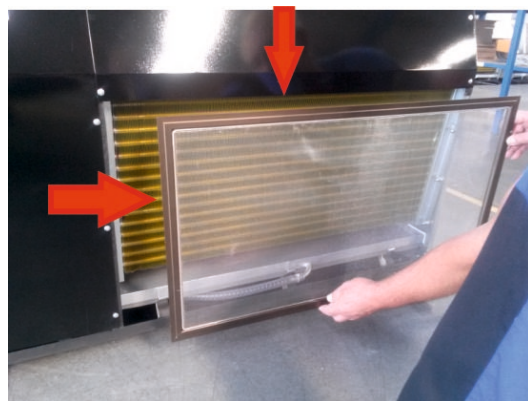

4. Remove the filter from the dehumidifier.

5. Clean the filter with a vacuum cleaner or rinse with clean warm water. If necessary, you can use a mild detergent. Allow the cleaned filter to dry. Do not expose the filter to the sun.

6. Then install the filter according to the above steps in reverse order.

A. Electrical installation FRESH AIR INTAKE WITH AUTOMATIC CONTROL OF BLINDS

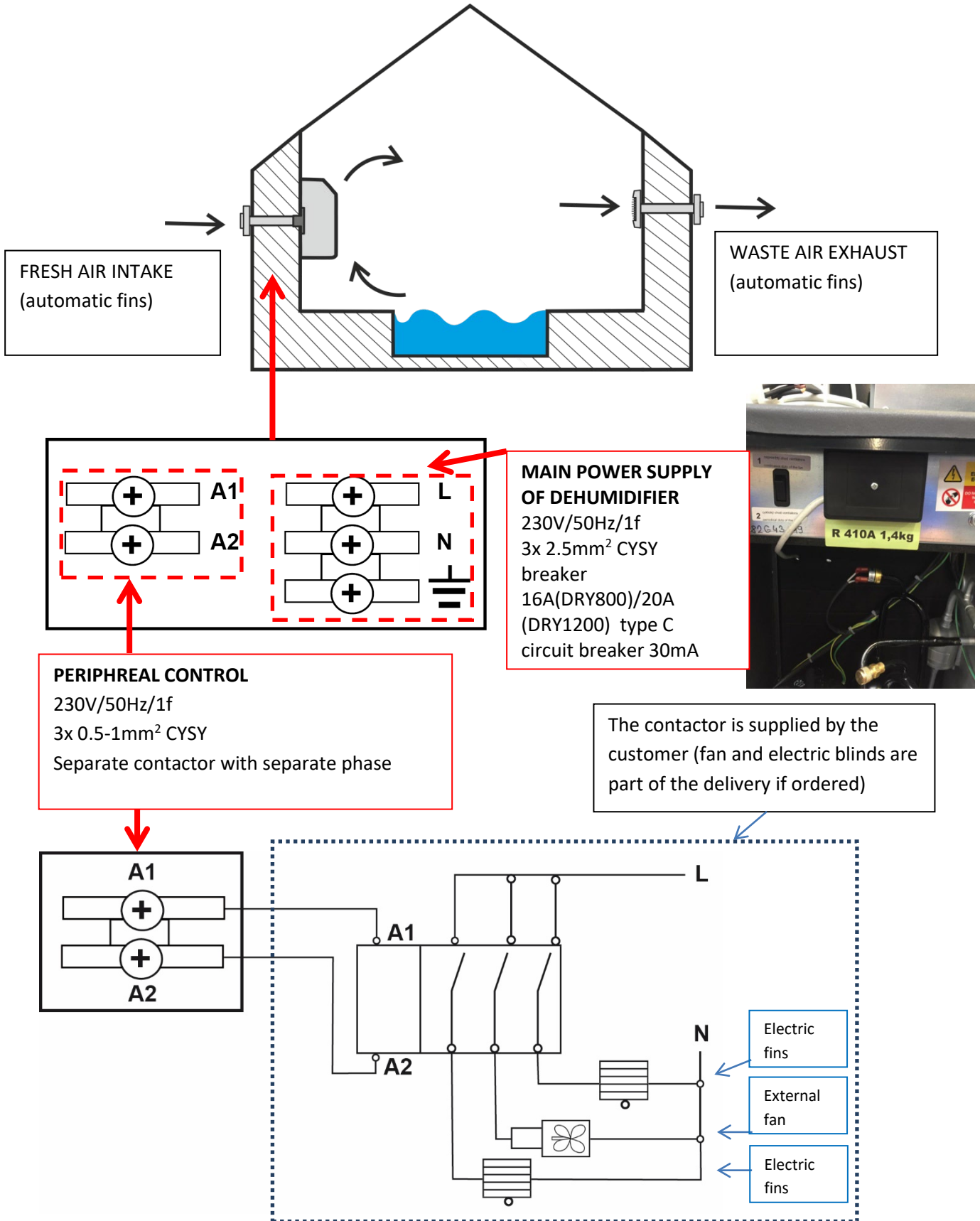

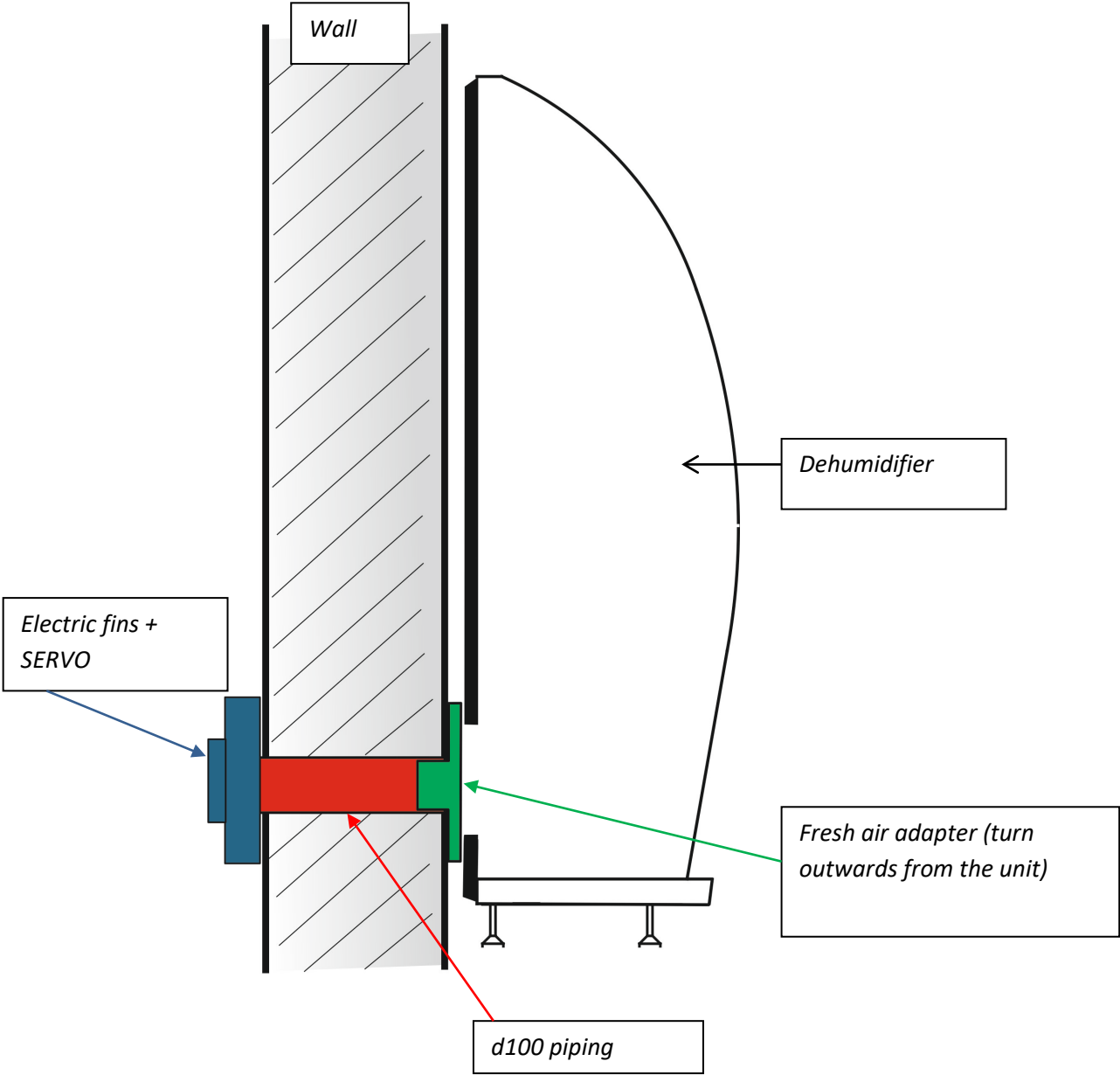

6 TECHNICAL DATA

6.1 Technical data chart*

Data	Unit	DRY 800 WAVE	DRY 1200 WAVE
For swimming pool with a max. water surface of:	m ²	60-90	90-120
Dehumidification performance at 30°C and 60% RV	l/24h	90	120
Dehumidification performance at 30°C and 70% RV	l/24h	112	150
Dehumidification performance at 30°C and 80% RV	l/24h	136	181
Operating temperature - defrost set	°C	22-35	22-35
Operating temperature - Thermostatic expansion valve (TEV)	°C	15-35	15-35
Operating temperature - defrost set + TEV	°C	35-42	35-42
Operating humidity + range	% RV	20-100	20-100
Air flow	m ³ /h	1100	1200
Noise (at 1m distance)	dB (A)	46	46
Heating output	W	5100	5250
El. input	W	1700	2400
Power supply	V/Hz/f	230/50/1	230/50/1
Operating/starting current	A	8/50	12/60
El. insulation – type C	A	16	20
Power cord	mm ²	CYSY 3C x 2.5	CYSY 3C x 2.5
Condensing pipe - outer diameter	mm	d 20	d 20
Net dimensions (width x height x depth)	mm	1250 x 950 x 310	1250 x 950 x 310
Net weight	kg	80	82
Refrigerant quantity - R 410 A	kg	1,65; 3,45 t CO ₂ ekv.	1,65; 3,45 t CO ₂ ekv.
Max. system pressure HP/LP	bar	35/14	35/17

* The manufacturer reserves the right to change the data without notice.

The refrigerant circuit is filled with R410A refrigerant, which is a two-component refrigerant (R32 / R125). These components are in accordance with Act No. 286/2009 Coll. in conjunction with Regulation (EC) No 1049/2001 of the European Parliament and of the Council 842/2006 considered as fluorinated greenhouse gases. The installations contain fluorinated greenhouse gases covered by the Kyoto Protocol:

**R410A with global warming potential (GWP) 2088:
(R-32/125 50/50)**

These data are for information only. The exact amount of refrigerant in the appliance is indicated on the rating plate (located at the back of the appliance in the upper right corner).

EL. CONNECTION SCHEME DRY 800 – BASIC CONNECTION DRY 800.1

21.06.2021

DRY 800.1 (OMRON)

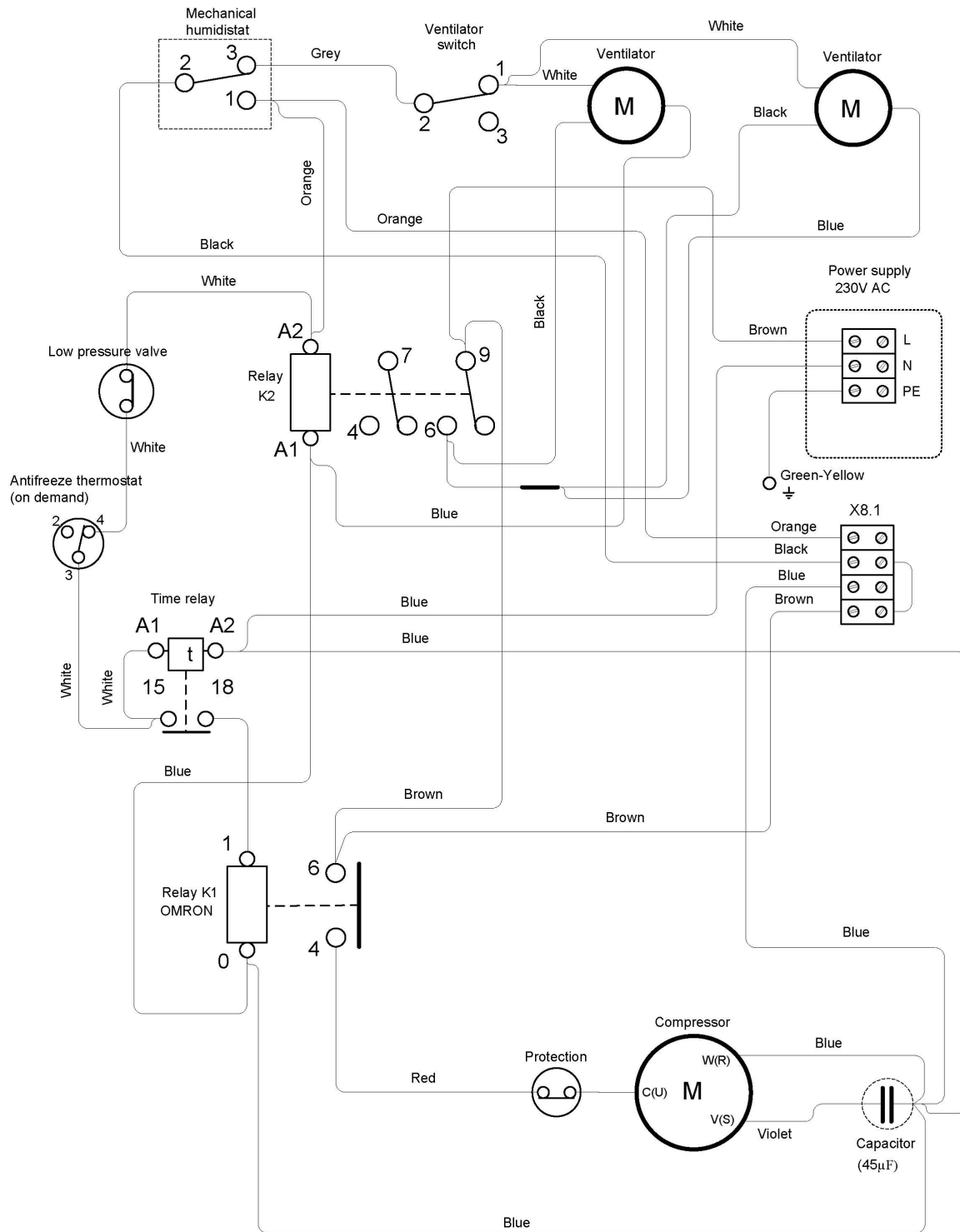

DRY 800.2

21.06.2021

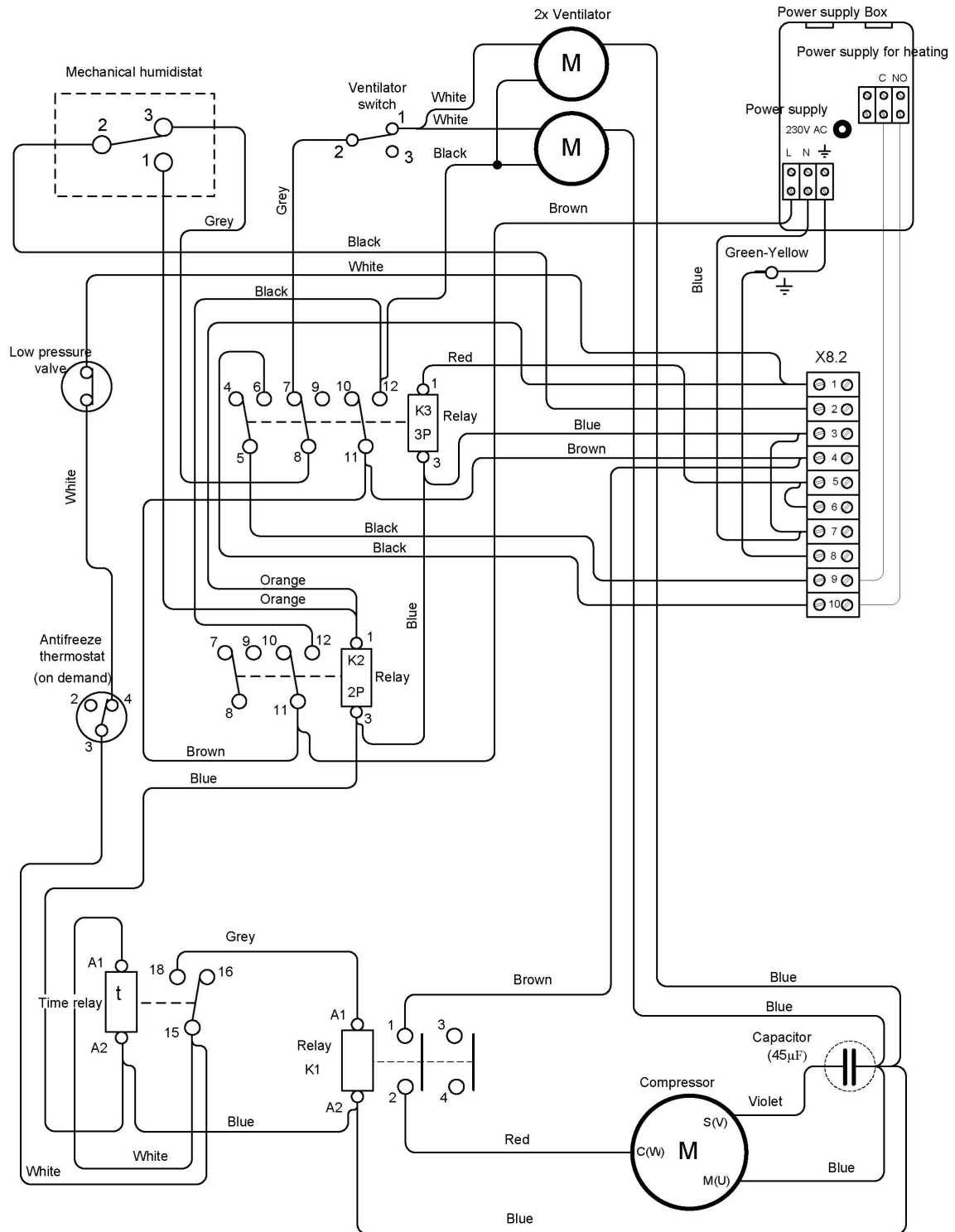

DRY 800.2 + El. heating 2000W

23.11.2021

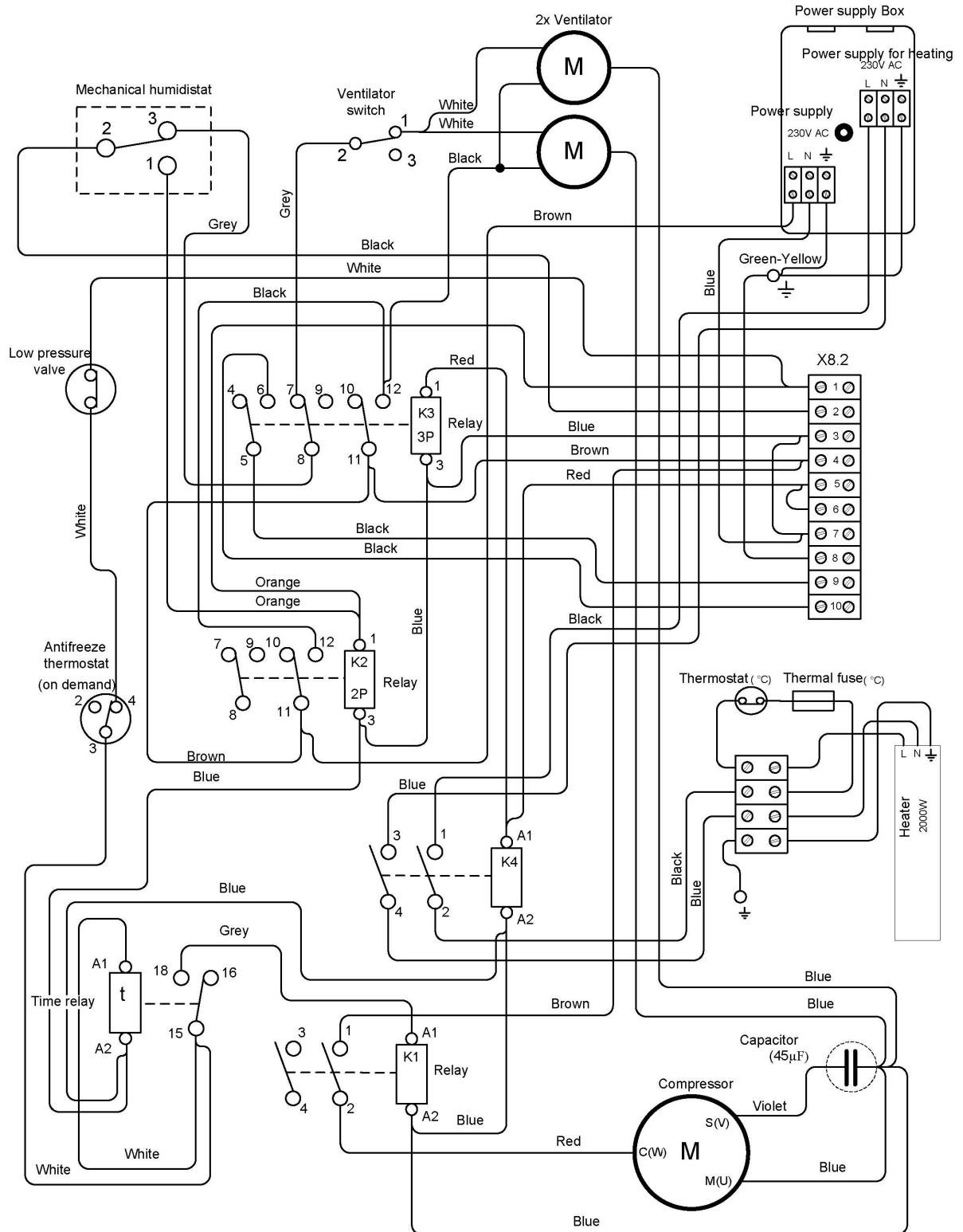

6.1.1 EL. CONNECTION SCHEME DRY 800 – ADVANCED CONNECTION

DRY 800.1 - Connection of terminal block X8.1 and humidity / thermostats 1401F, EASY 300, EBERLE

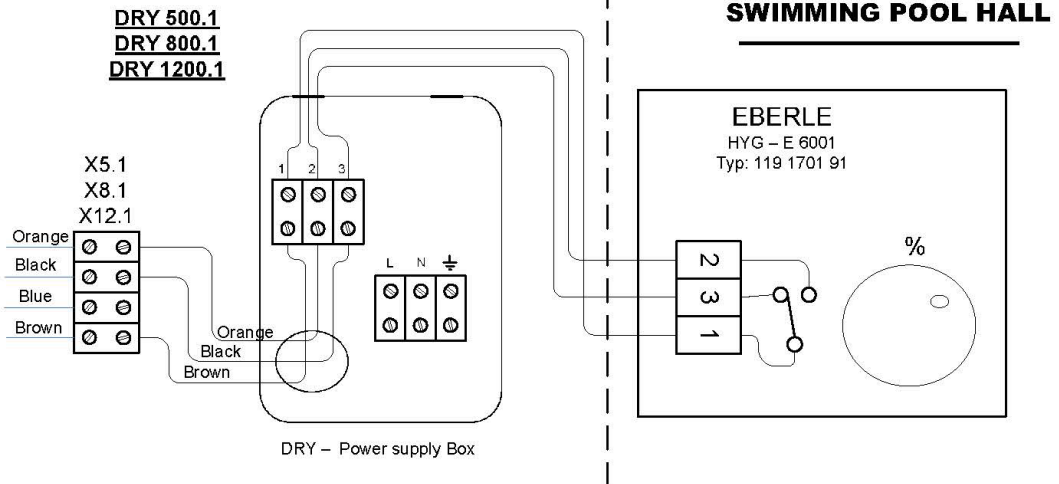
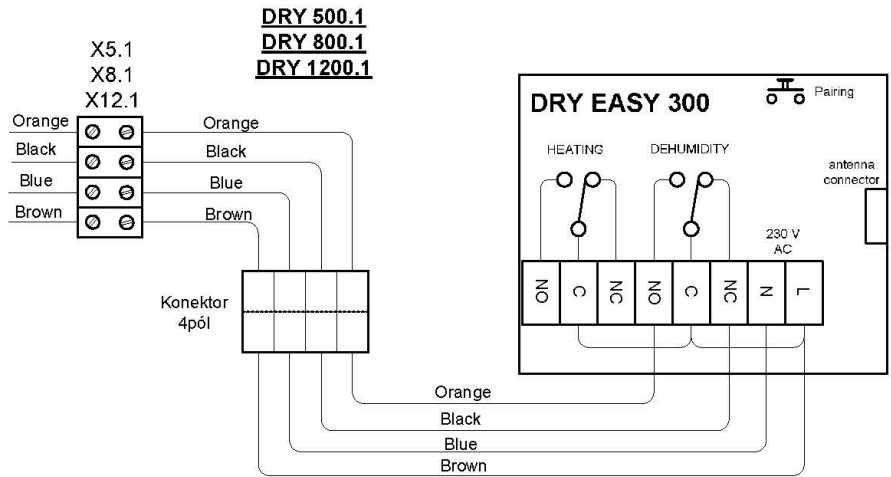

DRY 800.2 - Connection of terminal block X8.2 and humidistat with thermostat, voltage-free heating contact and solenoid valve

**DRY 500.2, 800.2, 1200.2 - X5.2, X8.2, X12.2
EASY 300**

30.8.2021

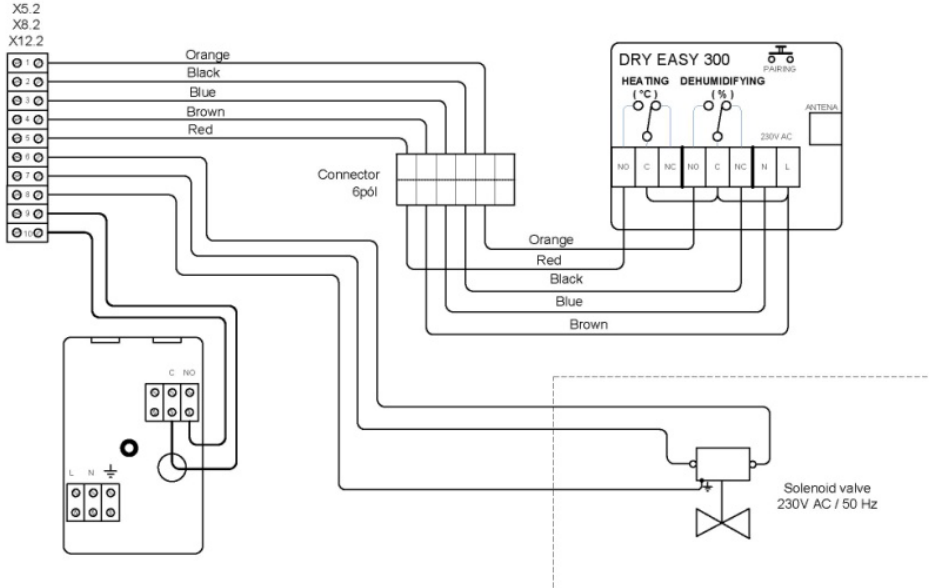

**DRY 500.2, 800.2, 1200.2 - X5.2, X8.2, X12.2
HYGROSTAT -TERMOSTAT EBERLE HYG-E7001**

3.9.2021

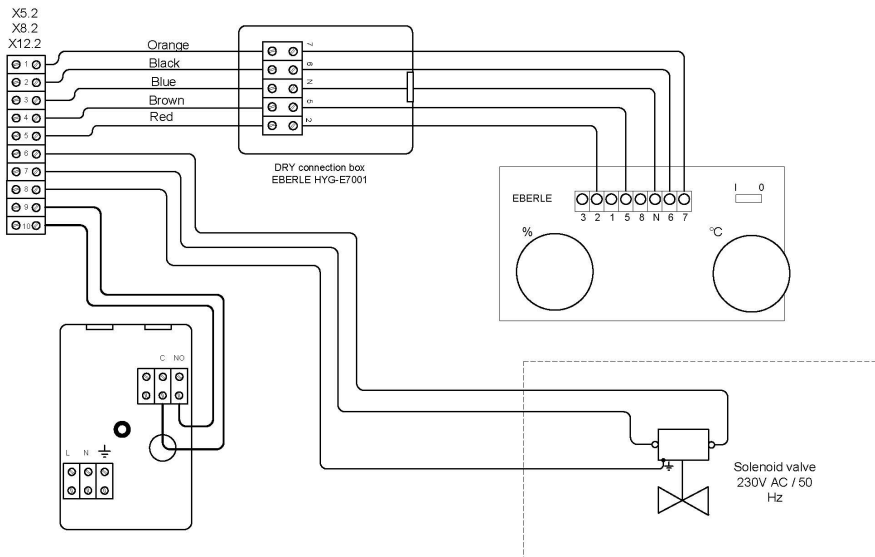

6.1.2 EL. CONNECTION SCHEME DRY 1200 – BASIC CONNECTION DRY 1200.1

21.06.2021

DRY 1200.1

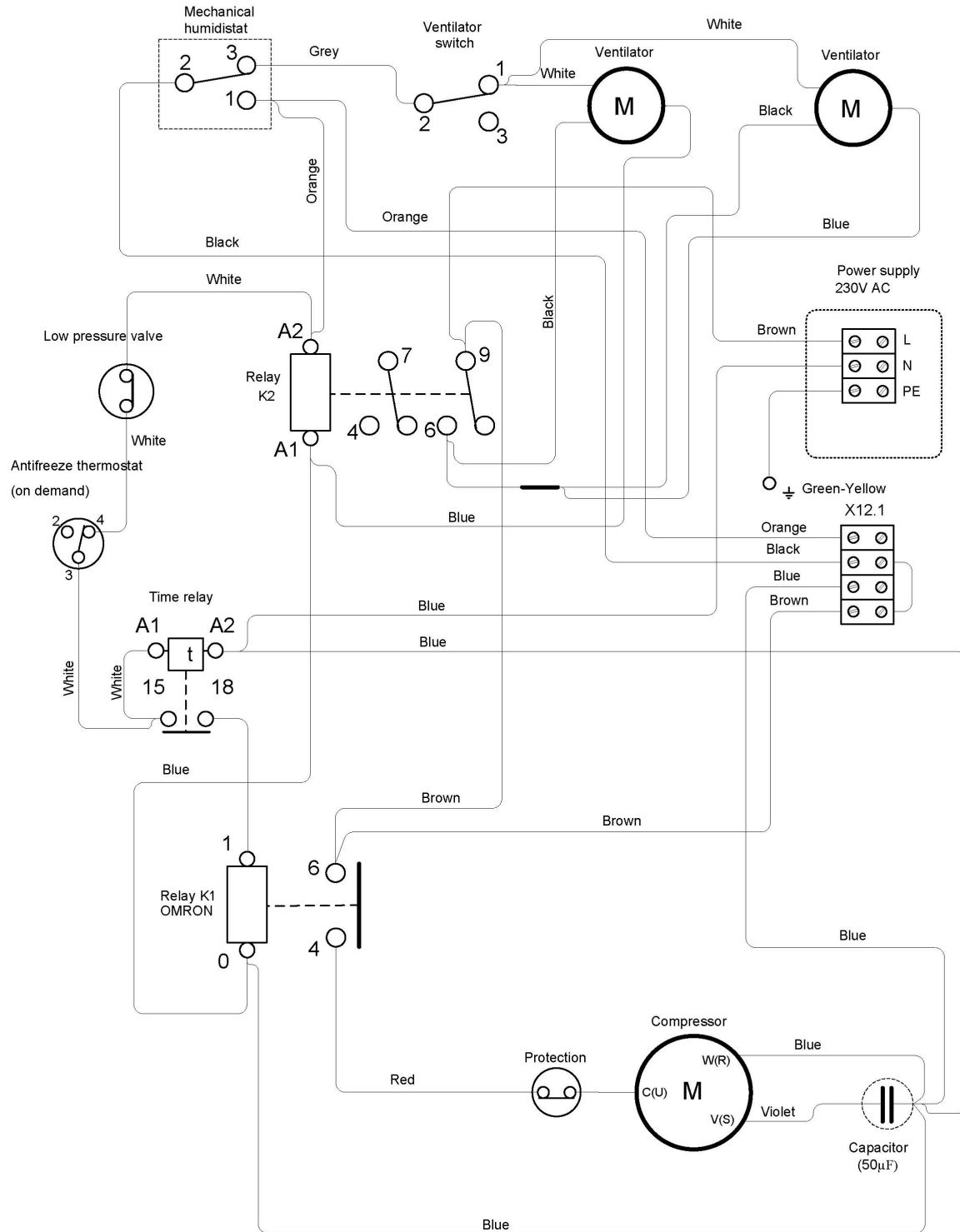

DRY 1200.2 (2021)

21.06.2021

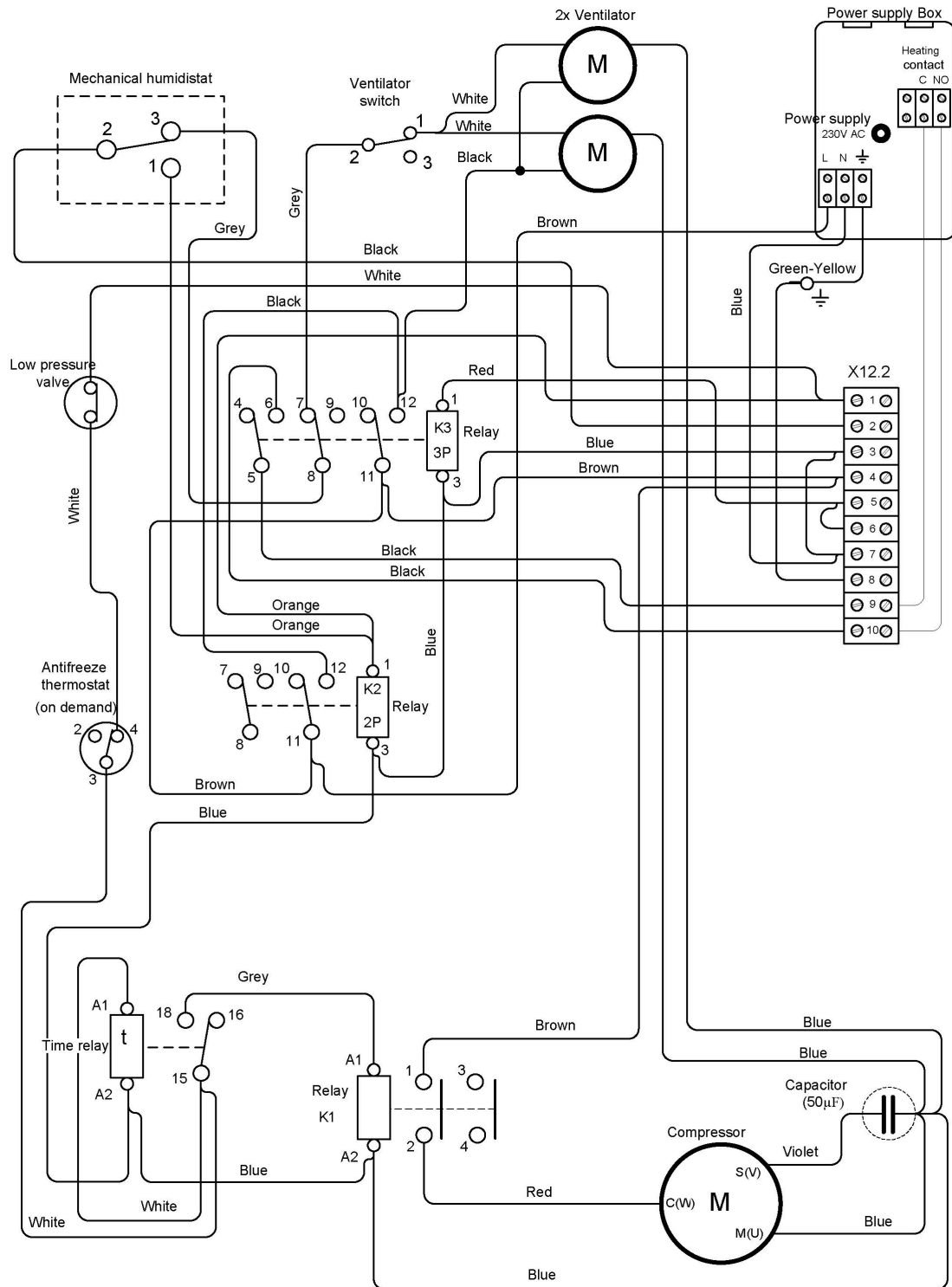

DRY 1200.2 + EI. heating 2000W

23.11.2021

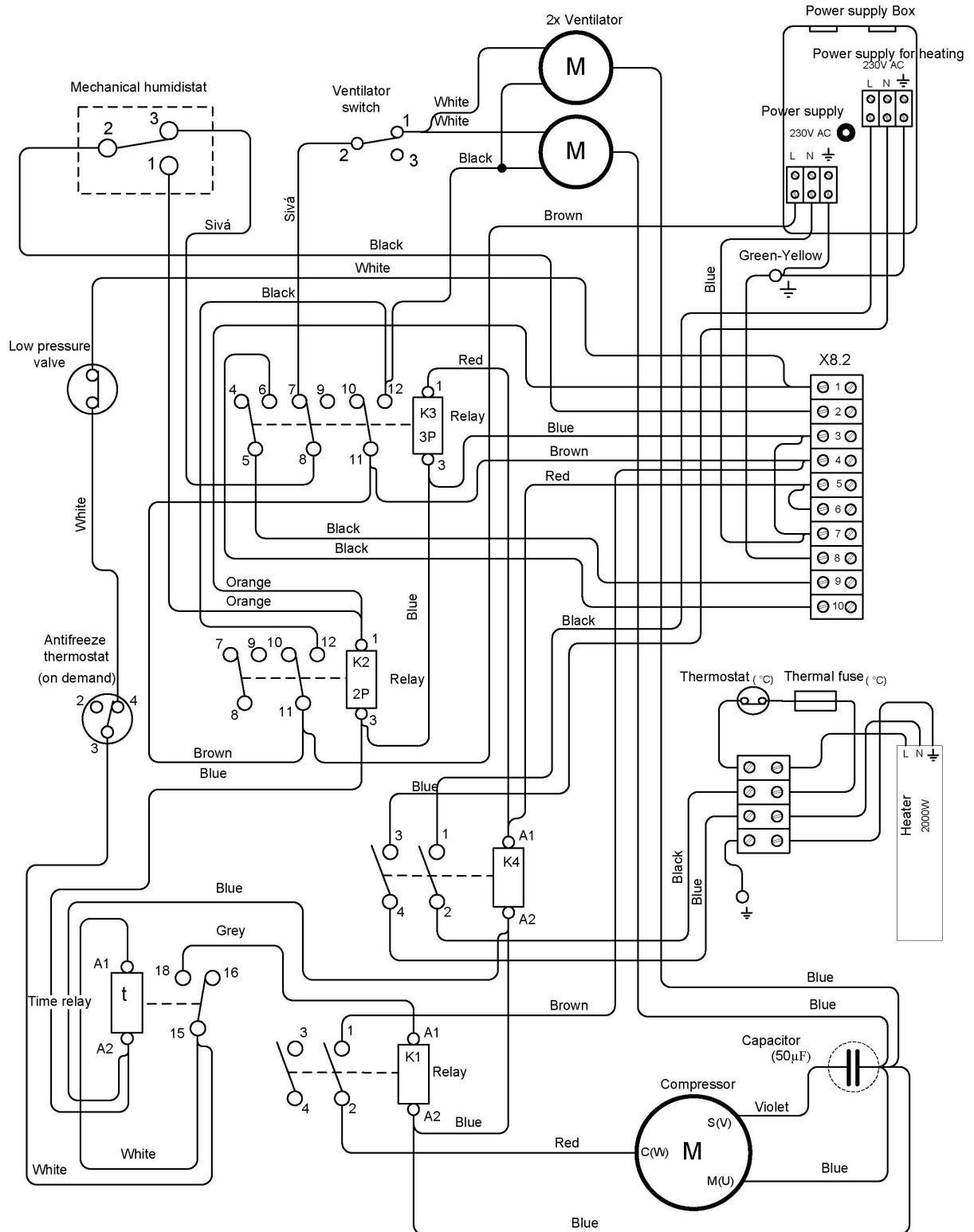

DRY 1200.1 - Connection of terminal block X12.1 and humidity / thermostats 1401F, EASY 300, EBERLE

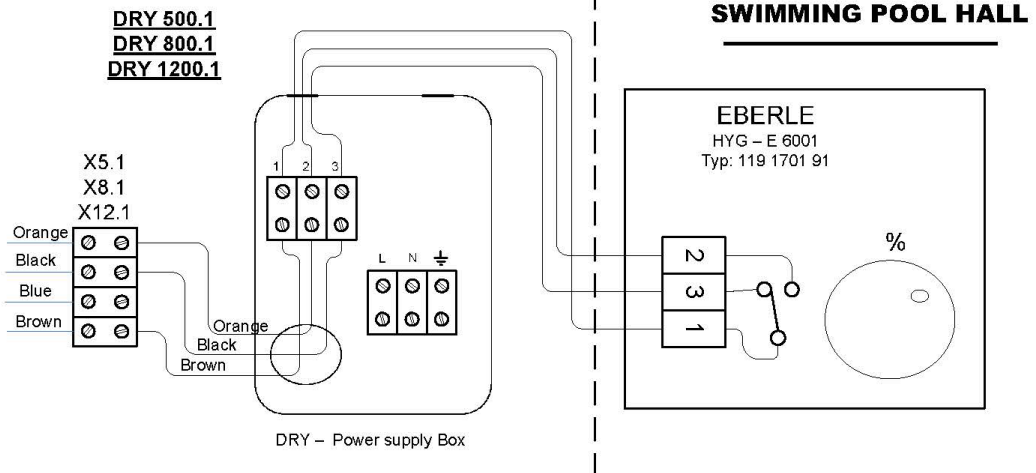
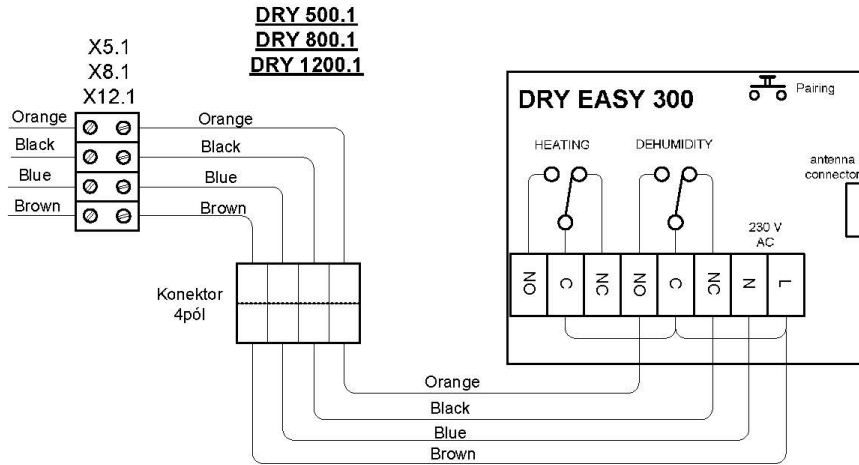

DRY 1200.2 - Connection of terminal block X12.2 and humidistat with thermostat, voltage-free heating contact and solenoid valve

**DRY 500.2, 800.2, 1200.2 - X5.2, X8.2, X12.2
EASY 300**

30.8.2021

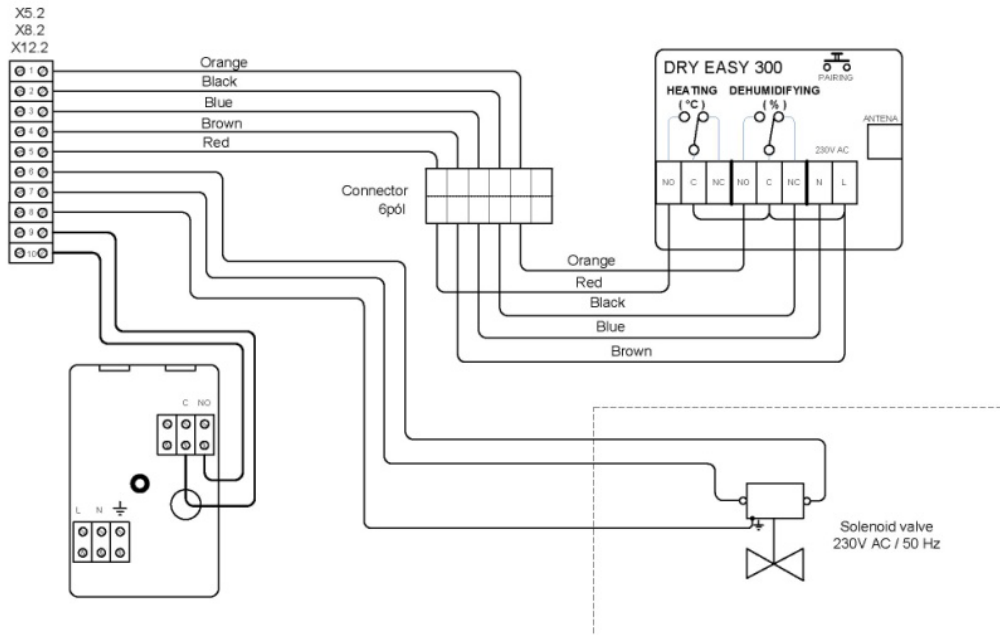

**DRY 500.2, 800.2, 1200.2 - X5.2, X8.2, X12.2
HYGROSTAT -TERMOSTAT EBERLE HYG-E7001**

3.9.2021

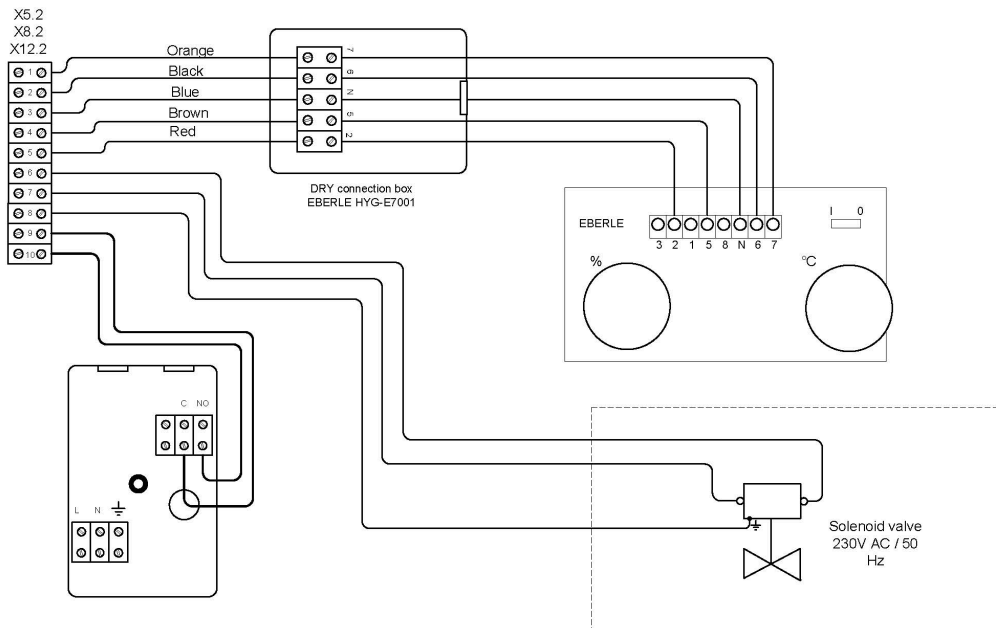

7 SUMMER SHUTDOWN

Users of indoor pools take the opportunity to shut down the dehumidifier for the summer. This is mainly due to favorable weather conditions during the summer - dry and warm weather. In this case, the natural air exchange regulates the humidity in the pool hall for several weeks/months of the year. However, with rapid weather changes (such as during rainy days), it can result in high humidity in your pool hall.

In this case, make sure that:

1. The dehumidifier circuit breaker is switched off (ie the dehumidifier has no power supply).
2. The dehumidifier cleans the air filter of dust or other contaminants that could settle and harden during downtime and be more difficult to remove later.
3. The dehumidifier is dried, the condensing tray does not contain water.
4. Make sure that the air inlet and outlet areas on the dehumidifier are adequately covered and protected from chlorine or other chemicals, especially the fan bearings. Failure to do so may result in bearing corrosion and damage to the dehumidifier.
5. Even during shutdown, we recommend releasing the dehumidifier at least once a month to prevent the fan grease from solidifying, after a few months the fan would not have to start at all.
6. **The manufacturer points out that during decommissioning of the dehumidifier, the humidity is not regulated in any way by the device and the device does not provide any drying function.**
7. **Make sure that the dehumidifier cannot be switched on when it is covered. This could cause the device to overheat and be damaged.**

7.1 Troubleshooting – save time and money

Error	Case / Description	Solution
Device does not work at all	Breaker out	Turn on the breaker
Device does not work at all	Circuit breaker out	Turn on the circuit breaker
Device does not work at all	Power supplier energy failure	Wait for the power to recover
Device doesn't dehumidify	The fan does not run or does but the dehumidifier does not dehumidify	Check the set value of the required humidity. If it is higher than the set value, set it to a lower value
Device doesn't dehumidify	4 min. after the fan has started, the compressor will also start but will switch off immediately after a few seconds	Check electronic components - compressor thermal fuse, switching relay, time relay, pressure switch
Device doesn't dehumidify	4 min. after the fan has started, the compressor will also start but only for a few minutes and then switch off	Check the refrigeration circuit - refrigerant may leak
The walls are wet	The device is dehumidifies but the walls are wet	Undersized dehumidification capacity. It needs to be supplemented with another dehumidifier.

7.2 Maintenance instructions

The device must be inspected and cleaned by a specialist at least once a year. This is essential to ensure the longevity and reliable operation of the equipment.

- Fixing the unit - visual inspection – is the unit OK? No cracks / damage / bends?
- Unit check - clean air inlet and outlet? No objects blocking air circulation?
- Air filter (if included) - cleaned air filter? Air filter inside?
- LPHW - connection is OK? No leakage? Is there hot water inside when turned on?
- Condensate drain - visual inspection - is it drained correctly? Does it clean from dust? No vibrations? No leakage? No water stains on the ceiling or wall?
- Electrical connection - visual inspection - is the connection OK? No burns? No damage? No odour?

7.3 Cleaning by superchlorination

Although MICROWELL DRY dehumidifiers are made of the most durable materials, chlorine is a very aggressive substance. The typical chlorine content in the pool air is up to 1.0 ppm. MICROWELL DRY dehumidifiers are equipped with a special protection against chlorine, but they cannot protect the unit in an environment with a chlorine content higher than 3.0 ppm. When cleaning the pool area with superchlorination, it must be borne in mind that the DRY dehumidifier must be switched off, as the chlorine concentration during superchlorination reaches up to 24 ppm. The unit must be switched off and ideally covered. Restore unit function after superchlorination and room ventilation.

7.4 Operation during construction

When you run the device in a pool that is still under construction, run it for a minimum of time. Do not turn on the device for more than a few minutes. Dust present in the air can collect on the heat exchanger and reduce the water collection capacity. Perform an initial test and demonstration, but leave the unit turned off and covered until the pool is completely constructed. **Make sure that the dehumidifier cannot be switched on when it is covered. This condition would overheat the device and damage it.**

7.5 microLIGHT+

The DRY300 / 400/500 can be equipped with the unique Microwell microLIGHT + system. It is a built-in LED strip that is located inside the unit. microLIGHT + will signal the current color humidity level.

BLUE - low humidity
GREEN - ideal humidity
YELLOW - humidity rises above a critical level
ORANGE - humidity rises above a critical level
RED - humidity too high

The ideal humidity in swimming pools is between 55% and 65% relative humidity. Humidity above 70% is too high and constantly deteriorates the materials in the pool and creates a favorable environment for bacteria. Moisture below 40% dries the mucosal tissue and is usually considered "dry". With microLIGHT+ you don't have to understand any image. **If it's green, everything's fine. If it's red, you have a problem.**

microLIGHT+ will also signal if your humidity is rising. For example, if you have a covered pool and the humidity is fine, you will see a green light. When you uncover it and start swimming, microLIGHT+ may turn yellow, orange or red after a while. This indicates that your humidity is rising. Don't be disturbed, it's normal. When you stop using the pool and cover it, the dehumidifier should dry the air in a maximum of a few hours (depending on the actual size of the pool) and the color should return to normal, i. j. Green. If red persists for more than 1 day, check the device.

8 WARRANTY CONDITIONS

The device is covered by a warranty period of 2 years. The warranty period can be extended by your reseller. Please contact your reseller or distributor if the warranty should be applied to the dehumidifier.

Use the following Microwell disclaimer under warranty. No claim will be accepted if:

1. The dehumidifier was used incorrectly, other than as described in this manual or in violation of this user manual, resp. against the safety precautions listed in this manual.
2. The dehumidifier has been installed incorrectly, other than as described in these operating instructions or in violation of this user manual.
3. The dehumidifier has been put into operation by an unauthorized person.
4. The air flow in the dehumidifier is outside the defined limits.
5. The device has been subjected to mechanical damage / forcible or any unauthorized action has been taken on the design of the unit - welding, soldering or mechanical damage by scratches, mixtures, compression, pipe rupture, etc. Without mechanical damage, the complaint is accepted, unless a written complaint is made with the equipment supplied by the carrier.
6. The chemical conditions in the pool were not within the defined limits (see the table of permitted chemical values below).
7. The dehumidifier has been exposed to frost or high temperatures outside the operating temperature range.
8. Power supply. Voltage insufficient or otherwise incorrect.
9. Switching the dehumidifier on/off by interrupting the electrical power supply during operation. (Device remains in standby by setting the humidity on the hygostat, e.g. set to 60%).



When requesting warranty, contact your distributor and have the device identifiers ready, i.e. model, serial number and date of purchase. Please describe the genesis of the failure. This will speed up the complaint handling process.

Acidity / pH level:	pH	7,4 +/- 0,4
Total alkalinity, CaCO ₃	ppm	80-120
Total hardness, CaCo ₃	ppm	100-300
Total dissolved dry matter	ppm	max. 3000
Maximum salt content (standard dehumidifier)	wt/wt	0.3% (3,000 ppm, 3 kg of salt per 1 m ³ of water)
Maximum salt content (dehumidifier with SALT+/SULPHUR+ treatment)	wt/wt	3% (30,000 ppm, 30 kg of salt per 1 m ³ of water)
Free chlorine range	ppm	1,0-3,0
Superchlorination	ppm	max. 30 ppm/max. 24 hours
Bromine	ppm	2-3
Baquacil	ppm	25-50
Ozone	ppm	0,8-1,0
Maximum copper content	ppm	max. 2
Aquamatic lone cleaner	ppm	max. 2
Tarn clean cleaner	ppm	max. 2

Sherwood cleaner	ppm	max. 2
------------------	-----	--------

Tab.: Permitted chemical value

TRANSPORTATION



*The dehumidifier must only be transported in the original packaging in an **upright vertical position**. When transporting, secure the dehumidifier against tipping over and falling. Never place the dehumidifier on its side! There is a risk of serious damage to the compressor! Damage during transport is never covered by the warranty! If you receive the shipment, check the integrity of the packaging and document any defects.*

Notes:

Notes:

Distributor:

Manufacturer:

MICROWELL, spol. s r.o.
SNP 2018/42, 927 01 Šaľa, Slovakia
tel.: +421/31/770 7082
e-mail: microwell@microwell.sk
www.microwell.eu



Made in: EUROPEAN UNION (SLOVAK REPUBLIC)
Country of Origin: EUROPEAN UNION (SLOVAK REPUBLIC)

www.microwell.eu