



MICROWELL

European manufacturer of swimming pool dehumidifiers, heat pumps and germicidal air purifiers.



2023 PRICE LIST

Swimming pool HEATING &
DEHUMIDIFICATION solutions
UV Air Disinfection systems

Valid from: FEBRUARY 17, 2023

WHY MICROWELL?

VARIETY OF MODELS

WIDEST RANGE OF DESIGN AND ACCESSORIES

EXCELLENT CRAFTSMANSHIP AND EXPERIENCE

INNOVATIVE ENGINEERING, CUTTING EDGE ROBOTICS

EUROPEAN QUALITY, LOCATED IN SLOVAKIA

750+ PARTNERS IN 40+ COUNTRIES

COMPETITIVE PRICES

ACCREDITED BY ISO 9001, ISO 14001, ISO 45001



Ing. Tibor Kovács, CEO

Dear Business Partners,

When I finished my regular annual speech back in January 2022, I had no idea what the future held for us for this Year. My thoughts were optimistic. COVID-19 world pandemic, that frightened us for two years, was on the wane, Global Chip Shortage was slowly but evidently improving, world logistics was getting back to normal. All the assumptions of global development pointed in one direction. For the better. And then came 24th February, 2022, and changed the world. Gunshots rang out in the neighboring state, buildings turned into burning wreckages under the fire of the occupiers. Suddenly everyone except for China stopped talking about COVID-19, and everything that hurt and annoyed us in the previous years was suddenly gone. This war has not stopped yet. It continues to this day. And the consequences of this war hurt us more and more each day. USD got so strong, energy prices are extra high, inflation is skyrocketing and the up to now so sensitive and prioritized global green program has become a marginal issue. In times, when lignite mines are being opened and huge tankers with LNG cargoes are teeming on the oceans, talking about green politics is – to put it mildly, hypocrisy.

Despite these sad facts, our company managed to increase production and total export by almost 27%. As for production, we relied on proven and internationally popular swimming pool dehumidifier and heat pumps. For Microwell 2022 was not a year of innovations and new product development.

It was above all a year of building new contacts. Our products conquered another continent - Australia. In addition, we recorded the first deliveries to Palestine and Azerbaijan. We currently export to more than 40 countries around the world. My unconcealed vision is to build the most progressive manufacturing factory here, in the center of Europe, in the near future.



There is still a long, thorny road leading to this, but where there is a will, there is a way. This year we finalized the building of our new warehouse. The total area of the warehouse increased to 1700m². In the first half of the year, we plan to build new test centers for heat pumps and dehumidifiers. In the heat pump test chamber, we will be able to simulate the temperature-humidity conditions of both the Arab Emirates and Scandinavia. Dehumidifiers will be tested also in extreme temperature and humidity conditions.

As a bonus, this year we are waiting for the start of the construction of a 4-story administrative center, where all company representatives - R&D, Sales and marketing staff together with production and service operators - will share the same place for work.

My credo is: Overtake in the corner! Where others slow down, we put on speed and overtake them. But to move safely after overtaking, we need your favor and above all your trust.

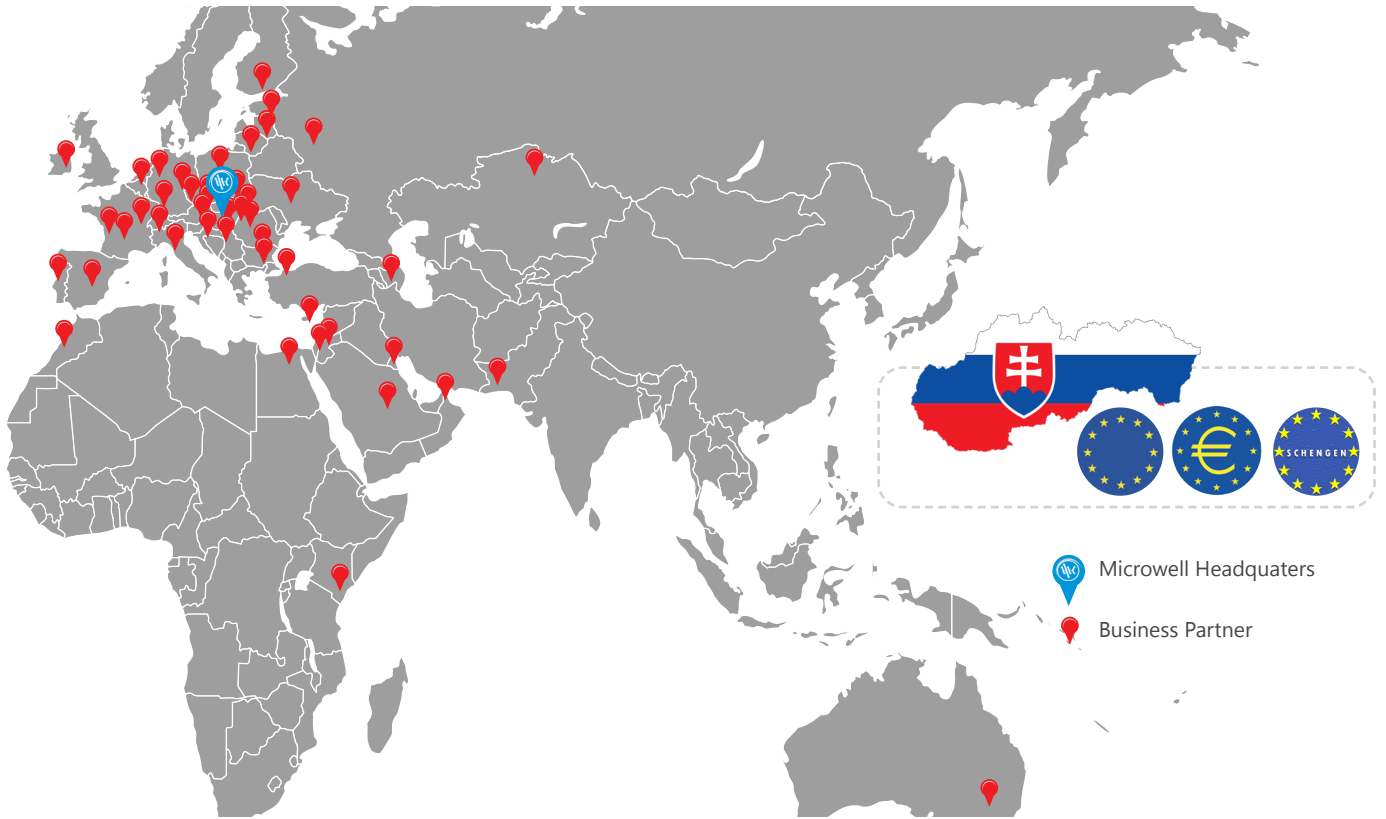
We promise, we will not let you down.



 Microwell Headquarters
 Business Partner



MICROWELL Headquarters

Microwell operates in 3 business divisions /Dehumidification, Heating and UV Air Disinfection Solutions, Measurement and Control, Air conditioning and Ventilation/, employs 70 employees in 5 Branch offices in 3 countries: Slovakia, Czech Republic, Hungary/. The company has own manufacturing facilities, warehouse, R&D department.

The core strength of Dehumidification, Heating and UV Air Disinfection Solutions Division is its R&D team, that works hard, permanently focused on customers needs, to find new solutions and innovations, e.g. DRY SIREN Eco with sophisticated engineering, outstanding quality a craftsmanship. They developed the fully new product - ATHMOSS Germicidal Air Purifier, closed germicidal air disinfector, equipped with a HEPA filter during worldwide COVID pandemia. In 2021 Microwell extended the germicidal air disinfectors production line with excellent Ceiling model - ATHMOSSphere.



Production & warehouse

Primary manufacturing facility located in 3.000m² venue. Office extends over 1.260m².



NEW WAREHOUSE





Germicidal Air Purifiers Pages 6 - 9

ATHMOSS germicidal air purifier

ATHMOSS 120 OFFICE
ATHMOSS 120 INDUSTRY
ATHMOSSphere

8-9



Dehumidifiers

Pages 10 - 33

SWIMMING POOL DEHUMIDIFIERS on the wall, on the floor, behind the wall

DRY 300 WAVE		
DRY 300 METAL		
DRY 300 SILVER	30m ² /36l	12-13
DRY 400 WAVE		
DRY 400 METAL		
DRY 400 SILVER	45m ² /48l	14-15
DRY 500 WAVE		
DRY 500 METAL		
DRY 500 SILVER	60m ² /66l	18-19
DRY 800 WAVE		20
DRY 1200 WAVE	90-120m ² /90-120l	
DRY 800 METAL		21
DRY 1200 METAL		
DRY SALT+ SULPHUR+		22

SWIMMING POOL DEHUMIDIFIERS ducted

DRY 300 DUCT		
DRY 400 DUCT		
DRY 500 DUCT		
DRY 800 DUCT		
DRY 1200 DUCT		24-27

SWIMMING POOL DEHUMIDIFIERS ceiling mounted

SIREN ECO MONO	60-120m ² /67-134l	28
SIREN ECO DUE		

DEHUMIDIFIERS FOR GALLERIES

DRY GALLERY		32
-------------	--	----

DEHUMIDIFIERS FOR INDUSTRY

T40 T90 T120		
TE40 TE90 TE120		33



Heat pumps

Pages 34 - 55

SWIMMING POOL HEAT PUMPS ON/OFF /up to 120 m³/

HP 1000 GREEN	9.2kW/45m ³	38
HP 1400 GREEN	12.3kW/55m ³	38
HP 1700 GREEN	16.2kW/70m ³	39
HP 2300 INVENTOR		
HP 2800 INVENTOR	23-28kW/80-120m ³	40-41

SWIMMING POOL HEAT PUMPS SEASONAL INVERTER /up to 50 m³/

HP 900 BLACK	9kW/30m ³	44
HP 1100 BLACK	11.5kW/35m ³	44
HP 1500 BLACK	15kW/50m ³	45

SWIMMING POOL HEAT PUMPS FULL YEAR INVERTER /up to 135 m³/

HP 1100 GREEN Inverter Pro	10kW/40m ³	46
HP 1500 GREEN Inverter Pro	15kW/60m ³	47
HP 1700 GREEN Inverter Pro	17kW/95m ³	48
HP 2100 GREEN Inverter Pro	24kW/105m ³	49
HP 2700 GREEN Inverter Pro	31kW/135m ³	50

SWIMMING POOL HEAT PUMPS FULL YEAR PREMIUM /up to 120 m³/

HP 2400 PREMIUM	24kW/80m ³	
HP 3000 PREMIUM	30kW/120m ³	52-53

COMMERCIAL SWIMMING POOL HEAT PUMPS INVERTER /up to 520 m³/

iMax 60		
iMax 110	60-115kW/260-520m ³	54



Accessories & Spare parts

Pages 56 - 71

QMAX-HEAT PUMP TESTER		57
HUMIDITY VISUALIZATION microLIGHT+		59
INSTALLATION MATERIAL AND EQUIPMENT FOR INSTALLATION AND SERVICE		61
WATER SURFACE COVER		69
VENTILATION		70

NEW IN 2023



HORIZON DRY

We are developing NEW line of swimming pool dehumidifiers called Horizon DRY. They are designed for concealed air ducting installation. Major feature is their horizontal built designed for hanging installation from the ceiling. Their extraction rate is designed to beat 150kg/day ideal for pools with up to 100m². Air flow is dimensioned to fit into any length up to about 50 meters.

Full model line read on **pages 30-31**.

HORIZON DRY

GO HORIZONTAL



NEW IN 2023

DRY SALT+ SULPHUR+

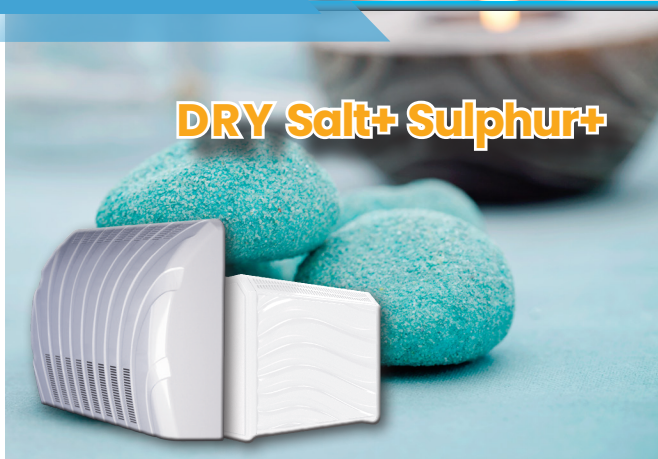

DRY Salt+ Sulphur+

DRY SALT+ SULPHUR+

Special treatment to withstand high concentrations of salt, sulphur and chlorine. Designed for natural salt/sulphur water spa, salt caves or alternatives with natural water spring spa that contains high concentrations of salt or sulphur. This special treatment can be applied also to high chlorine concentration pools where it provides higher resistance thereby longer livelihood of the device. Treatment is also designed to avoid formation of sulphuric acid (H₂SO₄).

Full model line read on **pages 22-23**.

INVISIBLE HEAT PUMP

There is no additional noise, vibration or visual disturbance since the split heat pump can be placed as far as 30 meters away from the jacuzzi.

An intuitive control panel with full integration into the jacuzzi's control is possible with RS-485, DRY contact or WLAN.

Split heat pump's water unit can be fully integrated inside the jacuzzi. It is thus fully invisible and also protected against frost.

Full model line read on **pages 36-37**.

INVISIBLE Heat pump

INVISIBLE HEAT PUMP FOR WHIRPOOLS



ATHMOSS ATHMOSSphere

The essential presence of the future.



Germicidal air purifiers

For offices, waiting rooms, retirement houses, event, fitness and shopping centers.

For industry premises, production halls.

**Professional, powerful
Air purifier & Disinfector
safe to use at presence of people**

Destroys viruses, bacteria and other microorganisms in the air.

The ATHMOSS germicidal air purifier will create a safe and healthy environment in your office, production hall or doctor's waiting room.



Series	ATHMOSS 120	ATHMOSS 120	ATHMOSSphere
Model	OFFICE	INDUSTRY	
Installation	wall mounted/on the floor with mobile stand		ceiling mounted
Recommended size of disinfected area	15-450 m ³	25-600 m ³	100-1000 m ³
Dimensions /WxHxD/	770 x 660 x 260 mm		Ø 1210 x 278 mm
Weight	20.5 kg	21.5 kg	
Cover	Acrylic, white		Acrylic, white
Noise level	33.5 dB(A) MIN 45.8 dB(A) MAX	39.1 dB(A) MIN 58.2 dB(A) MAX	34 dB(A) MIN 62 dB(A) MAX
Air flow	50-495 m ³ /h, adjustable	50-700 m ³ /h, adjustable	400-800 m ³ /h, adjustable
Power supply	230V AC/50Hz/1ph		230V AC/50Hz/1ph
Consumption	95-100-152 W	188-237 W	270-380 W
Number and performance of UV-C tubes	6 x 15 W /253.7 nm UV-C/		12 x 15 W /253.7 nm UV-C/
Operating life-time of UV-C tubes	<9000h		<9000h
Prefilter	Class G3 >10µm		Class G3 >10µm
HEPA filter	Class H11 >0.3µm, 95%		Class H11 >0.3µm, 95%

Manufacturer notice: Manufacturer reserves the right to change the technical parameters without notice.

Tested and confirmed by the Institute of Clinical Microbiology, Faculty of Medicine UK in Hradec Králové, Czech Republic.



Effect of the air purifier ATHMOSS INDUSTRY 120 on artificial contaminated laboratory air pollution of bacteria - 47m³

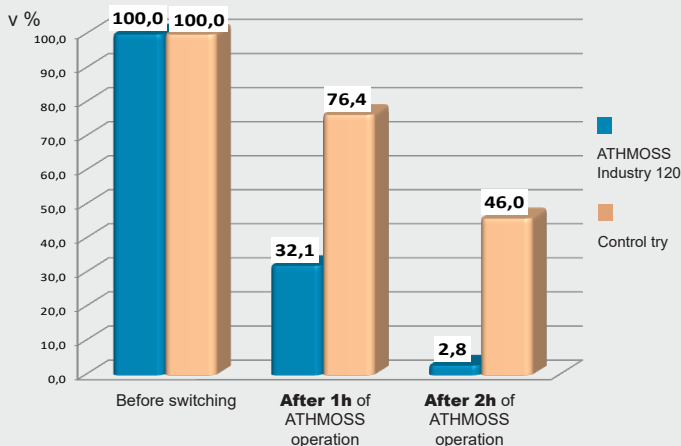

Effect of the air purifier ATHMOSSphere on artificial contaminated laboratory air pollution of bacteria - 126m³

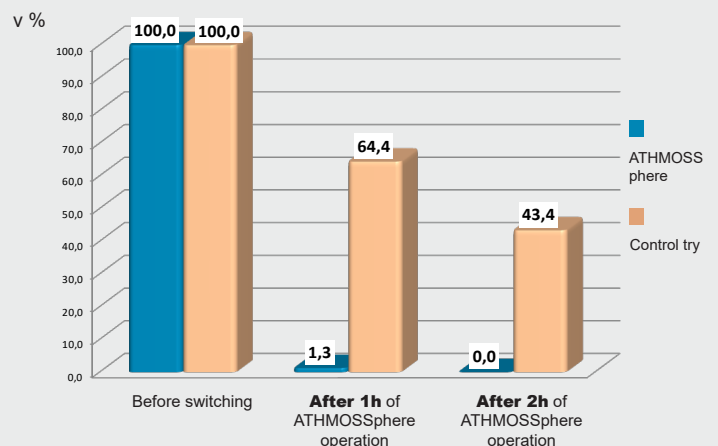

90W
495 m³**ATHMOSS 120 OFFICE***Quiet, yet effective.*90W
700 m³**ATHMOSS 120 INDUSTRY***Powerful without compromise.*

Cover	Acrylic, white	
UV-C tubes	6x15W /253,7 nm/	
Air flow	50-495 m ³ /h	50-700 m ³ /h
Prefilter	Class G3 >10 µm	
HEPA filter	Class H11 >0,3 µm, 95%	
microMETAL+ stainless steel filter		
Installation	Wall mounted	

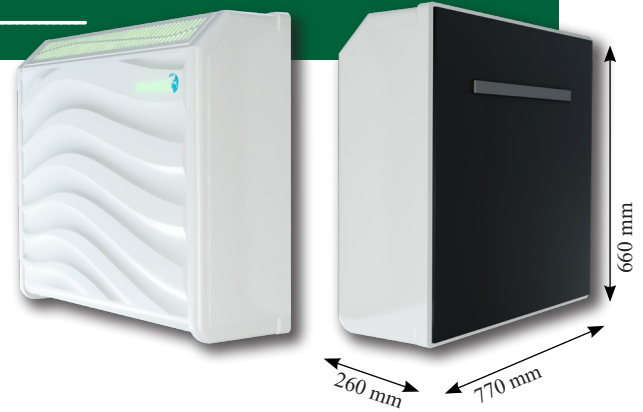
ATHMOSS **ATHMOSS 120 O** - **1.****ATHMOSS 120 I** - **1.**

Basic equipment:	Model:	Price EXW Sala, SK w/o VAT
Germicidal air purifier, wall console, 90W UV-C <9.000hrs, G3 prefilter, H11 95% HEPA filter, microMETAL+ stainless steel filter, user's manual	ATHMOSS 120 OFFICE	1 980 €
	ATHMOSS 120 INDUSTRY	2 150 €

1. Installation:

S Standard: on the wall	0 €
M Mobile stand (vertically adjustable 145-185cm), RAL9010 white, 4 wheels (2 lockable): <i>/Rebate does not apply on this item. This is the actual purchase price./</i>	115 €
P Through-the-wall installation (Fiberglass cover with through-the-wall ducts set and removable aluminium grills, metal duct galvanized, wall thickness >400mm, insulated)	385 €

**1-M**

Spare parts:	Price EXW Sala, SK w/o VAT
Spare Disinfection chamber with 90W UV-C, with microMETAL+ stainless steel filter and HEPA filter H11	760 €
HEPA filter H11, 1pc, >0.3µm, 95% <i>/Rebate does not apply on this item. This is the actual purchase price./</i>	15 €
Pre-filter class G3, package of 3pcs, >10µm <i>/Rebate does not apply on this item. This is the actual purchase price./</i>	9 €

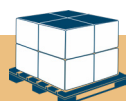
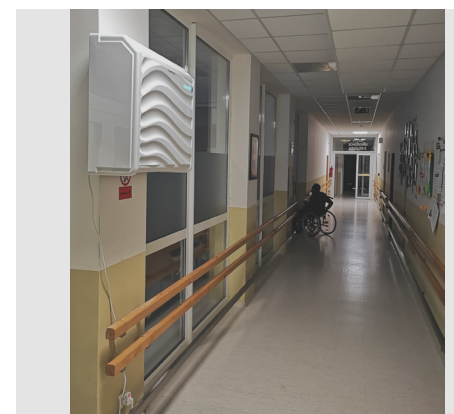
**1-P**EURO PALETTE packed, FUMIGATED
17.50€/1pc (Depending on the model it is possible to pack more units on EUP (2-6pcs).)

180W
495 m³

ATHMOSSphere

The essential presence of the future.

ATHMOSSphere

Cover	Acrylic, white
UV-C tubes	12x15W /253,7 nm/
Air flow	400-800 m ³ /h adjustable
Prefilter	Class G3 >10 µm
HEPA filter	Class H11 >0,3 µm, 95%
microMETAL+ stainless steel filter	
Installation	Ceiling mounted



278 mm

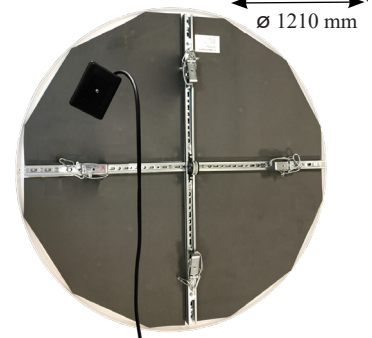

GERMICIDAL AIR PURIFIER



ATHMOSSphere

Basic equipment:

Price EXW Sala, SK
w/o VAT

Ceiling germicidal air purifier, 180W UV-C <9.000hrs, G3 prefilter, H11 95% HEPA filter, microMETAL+ stainless steel filter, ceiling lifting mechanism, user's manual

3 150 €

Spare parts:

Price EXW Sala, SK
w/o VAT

Spare Disinfection chamber with 180W UV-C, with microMETAL+ stainless steel filter and HEPA filter H11

1 250 €

HEPA filter H11, 1pc, >0.3µm, 95%
/Rebate does not apply on this item. This is the actual purchase price./

15 €

Pre-filter class G3, package of 3pcs, >10µm
/Rebate does not apply on this item. This is the actual purchase price./

9 €



EURO PALETTE packed, FUMIGATED
17.50€/1pc
(Depending on the model it is possible to pack more units on EUP (2-6pcs).)



v. 01/2023

 MICROWELL



Dehumidifiers

For swimming pools, hotel pools, spa and jacuzzi
For galleries, museums and libraries
For industry

























Swimming pool humidity under control

Microwell dehumidifiers solve humidity problems and maintain healthy pool environment by removing condensation and wet wall odour, and providing free heating through heat recovery.

Working on the principle of condensation, DRY swimming pool dehumidifiers are removing humid air from swimming pool hall, replacing it with dry and warm air.

MICROWELL DRY

Line 2023

		Pool surface	Extraction rate	Extraction rate	Air flow	Noise level (at 1m distance)	Power consumption	Heating output	Dimensions	Weight
		m ²	l/24hrs /60% RH, 30°C/	l/24hrs /80% RH, 30°C/	m ³ /h	dB(A)	W	W	netto	netto
Model									mm	kg
Economy class - WAVE	 DRY 300 WAVE	30	36	48	550	42	700	1900	780 x 660 x 255	40
	 DRY 400 WAVE	45	48	58	600	42	700	1900	780 x 660 x 255	40
	 DRY 500 WAVE	60	66	101	800	44	1000	3500	1245 x 660 x 255	60
	 DRY 800 WAVE	90	90	136	1100	46	1600	5100	1250 x 950 x 310	80
	 DRY 1200 WAVE	120	120	181	1200	46	2150	5250	1250 x 950 x 310	82
Premium class - METAL	 DRY 300 METAL	30	36	48	550	42	700	1900	780 x 642 x 300	50
	 DRY 400 METAL	45	48	58	600	42	700	1900	780 x 642 x 300	50
	 DRY 500 METAL	60	66	101	800	44	1000	3500	1245 x 642 x 300	77
	 DRY 800 METAL	90	90	136	1100	46	1600	5100	1250 x 950 x 310	100
	 DRY 1200 METAL	120	120	181	1200	46	2150	5250	1250 x 950 x 310	101
LUXURY class - SILVER	 DRY 300 SILVER	30	36	48	550	42	700	1900	780 x 642 x 300	50
	 DRY 400 SILVER	45	48	58	600	42	700	1900	780 x 642 x 300	50
	 DRY 500 SILVER	60	66	101	800	44	1000	3500	1245 x 642 x 300	77
Through-the-wall	 DRY 300 TTW	30	36	48	550	42	700	1900	880 x 658 x 240	56
	 DRY 400 TTW	45	48	58	600	42	700	1900	880 x 658 x 240	56
	 DRY 500 TTW	60	66	101	800	44	1000	3500	1245 x 660 x 255	60
	 DRY 800 TTW	90	90	136	1100	46	1600	5100	1247 x 950 x 300	100
	 DRY 1200 TTW	120	120	181	1200	46	2150	5250	1247 x 950 x 300	103
Ducted	 DRY 300 DUCT	30	32	43	500/200Pa	54	800	1900	880 x 658 x 240	56
	 DRY 400 DUCT	40	43	56	500/200Pa	54	800	1900	880 x 658 x 240	56
	 DRY 500 DUCT	50	52	68	1000/200Pa	56	1150	3500	1250 x 660 x 250	78
	 DRY 800 DUCT	80	88	135	1100/170Pa	58	1700	5100	1247 x 950 x 300	102
	 DRY 1200 DUCT	110	112	170	1200/145Pa	60	2250	5250	1247 x 950 x 300	103
Ceiling	 SIREN Eco MONO	60	67	104	1000	35	1000	4500	Ø 1210 x 278	53+20
	 SIREN Eco DUE	120	134	208	2000	35	2300	8750	2x Ø 1210x 278	2x53+30

The manufacturer reserves the right to change the parameters without notice.

36 l
30 m²

DRY 300 WAVE

Cover	Extraction rate (30°C/60% RH - 35°C/95% RH)	Air flow
plastic (acryl)	36-63 l/24hrs	550 m ³ /hour

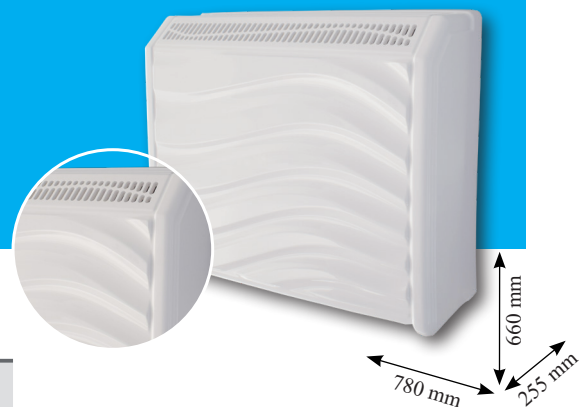

DRY 300W - 1. - 2. - 3. - 4. - 5. - 6. - 7. - 8.

Basic equipment:	Price EXW w/o VAT /EUR/
------------------	----------------------------

Dehumidifier, wall console, user's manual, installation layout, fixation screws

micro COMPRESSOR+ ultra QUIET+ easy INSTALL+



2 630

1. Installation:

S standard: on the wall	0
M mobile stand, 4 wheels, white color (RAL 9010), 230V EURO plug, 2m	235
F fixed floor stand, color: black RAL9005, 230V EURO plug, 2m	260
P through-the-wall INDOOR INSTALLATION (fiberglass cover with TTW ducts set and removable aluminum grills, metal ducts galvanized, insulated)	495
T Premium through-the-wall INDOOR INSTALLATION (metal powder coated cover, wall ducts, removable grills, metal ducts galvanized, insulated)	1 290
E through-the-wall OUTDOOR INSTALLATION (40mm TTW external aluminum and rubber insulation, winter module, condensate tray defrost, -15°C), fiberglass cover	1 350

2. Control:

S standard: built-in mechanical humidistat	0
E remote wireless humidistat & thermostat DRY EASY 300 + built-in mechanical humidistat	345
W6 remote wired humidistat EBERLE HYG6001+built-in mechanical humidistat	119
W7 remote wired humidistat & thermostat EBERLE HYG7001+built-in mechanical humidistat	129

3. Air temperature:

S standard: +22°C...+35°C	0
T +15°C...+35°C (with antifreeze thermostat)	57
V +22°C...+42°C (with thermostatic expansion valve)	259
A +15°C...+42°C (T+V)	279
F +5°C...+35°C (with 4-way valve hot gas defrost)	385

4. Air heating:

S standard: without LPHW (Low Pressure Hot Water)	0
H LPHW, 3.5 kW, without regulation, contact for external thermostat 230V/5A	228
V LPHW, 3.5 kW, with solenoid valve (in standard version – external contact 230V/5A) (with EASY 300 – fully automatic regulation + no current contact)	442
E Electrical heating 2 kW	486

5. LPHW connection:

S standard: N/A (without LPHW)	0
B from the back	0
R from right	0
L from left	0

6. micro LIGHT+

S standard: without Pool Security microLIGHT+	0
L Pool Security microLIGHT+	147

7. Air filter:

S standard: without air filter	0
F Air filter (for model with wall or mobile stand installation: 1-S/M option)	52
C Air filter grid (for model with TTW installation: 1-P/E option)	52

8. Fresh air supply:

S standard: without fresh air supply	0
F adapter, Ø 100 mm, 50 mm length, galvanized	35

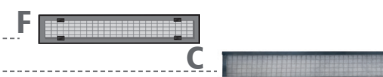
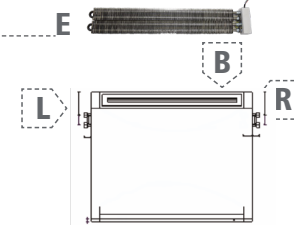
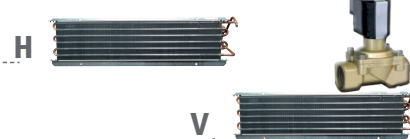
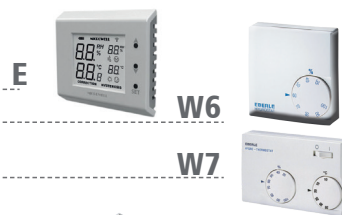
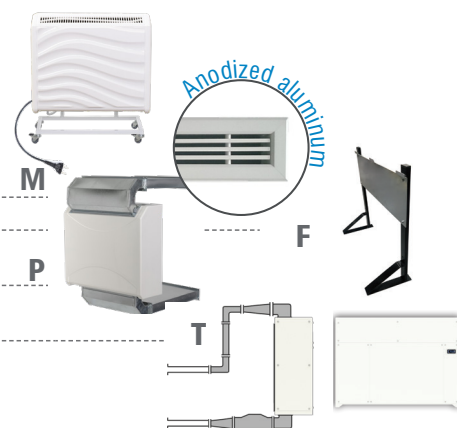

EURO PALETTE packed, FUMIGATED
17.50€/1pc (Depending on the model it is possible to pack more units on EUP (2-6pcs).)

36 l
30 m²

DRY 300 METAL | DRY 300 SILVER

Cover	Cover	Extraction rate	Air flow
DRY 300 METAL	DRY 300 SILVER	(30°C/60% RH - 35°C/95% RH)	
metal	stainless steel	36-63 l/24hrs	550 m ³ /hour



DRY 300M



DRY 300S

642 mm
780 mm
300 mm

SWIMMING POOL DEHUMIDIFIERS



DRY 300M - 1. - 2. - 3. - 4. - 5. - 6. - 7. - 8. - 9.

DRY 300S - - 2. - 3. - 4. - 5. - 6. - 7. - 8. - 9.

Basic equipment:	Model:	Price EXW w/o VAT /EUR/
Dehumidifier, wall console, user's manual installation layout, fixation screws	DRY 300 METAL	3 090
micro COMPRESSOR+ ultra QUIET+ easy INSTALL+ 	DRY 300 SILVER	4 000
1. Color options:		
S standard: silver color „Tiger“		0
W white (RAL9010) glossy		0
C color selection according to your preference (RAL code)		price on demand
2. Installation:		
S standard: on the wall		0
M mobile stand, 4 wheels, color: silver 'Tiger', white (RAL 9010), 230V EURO plug, 2m		235
F fixed floor stand, color: black RAL9005, 230V EURO plug, 2m		260
3. Control:		
S standard: built-in digital humidistat & thermostat + built-in mechanical humidistat		0
E remote wireless humidistat & thermostat DRY EASY 300 + built-in mechanical humidistat (without built-in digital humidistat & thermostat)		345
W6 remote wired humidistat EBERLE HYG6001 + built-in mechanical humidistat (without built-in digital humidistat & thermostat)		79
W7 remote wired humidistat & thermostat EBERLE HYG7001+built-in mechanical humidistat (without built-in digital humidistat & thermostat)		88
4. Air temperature:		
S standard: +22°C...+35°C		0
T +15°C...+35°C (with antifreeze thermostat)		57
V +22°C...+42°C (with thermostatic expansion valve)		259
A +15°C...+42°C (T+V)		279
F +5°C...+35°C (with 4-way valve hot gas defrost)		385
5. Air heating:		
S standard: without LPHW (Low Pressure Hot Water)		0
H LPHW, 3.5 kW, without regulation (external no current contact)		228
V LPHW, 3.5 kW, fully automatic regulation (with solenoid valve + external no current contact)		442
E Electrical heating 2 kW		486
6. LPHW connection:		
S standard: N/A (without LPHW)		0
B from the back		0
R from right		0
L from left		0
7. micro LIGHT+		
S standard: without Pool Security microLIGHT+		0
L Pool Security microLIGHT+		147
8. Air filter:		
S standard: without air filter		0
F Air filter		52
9. Fresh air supply:		
S standard: without fresh air supply		0
F adapter, Ø 100 mm, 50 mm length, galvanized		35

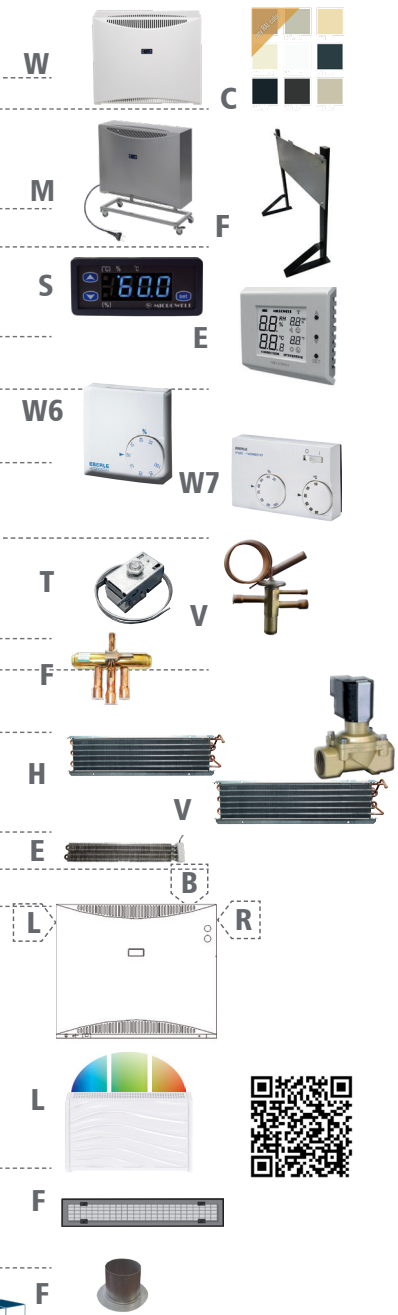

 **EURO PALLETTE packed, FUMIGATED**
17.50€/1pc (Depending on the model it is possible to pack more units on EUP (2-6pcs).)



v. 01/2023



48 l
45 m²

DRY 400 WAVE

Cover	Extraction rate (30°C/60% RH - 35°C/95% RH)	Air flow
plastic (acryl)	48-78 l/24hrs	600 m ³ /hour

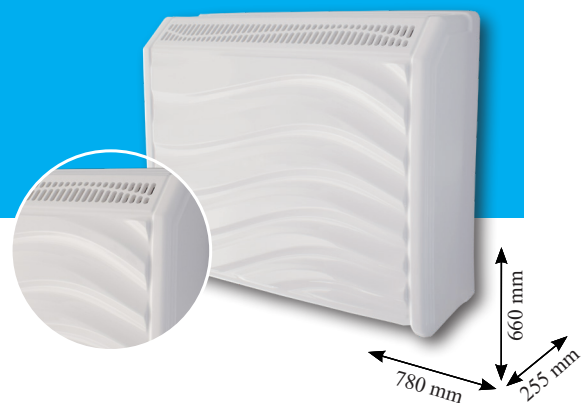

DRY 400W - 1. - 2. - 3. - 4. - 5. - 6. - 7. - 8.

Basic equipment:

Price EXW
w/o VAT /EUR/

Dehumidifier, wall console, user's manual, installation layout, fixation screws

micro COMPRESSOR+ ultra QUIET+ easy INSTALL+



3 040

1. Installation:

S standard: on the wall	0
M mobile stand, 4 wheels, white color (RAL 9010), 230V EURO plug, 2m	235
F fixed floor stand, color: black RAL9005, 230V EURO plug, 2m	260
P through-the-wall INDOOR INSTALLATION (fiberglass cover with TTW ducts set and removable aluminum grills, metal ducts galvanized, insulated)	495
T Premium through-the-wall INDOOR INSTALLATION (metal powder coated cover, wall ducts, removable grills, metal ducts galvanized, insulated)	1 290
E through-the-wall OUTDOOR INSTALLATION (40mm TTW external aluminum and rubber insulation, winter module, condensate tray defrost, -15°C), fiberglass cover	1 350

2. Control:

S standard: built-in mechanical humidistat	0
E remote wireless humidistat & thermostat DRY EASY 300 + built-in mechanical humidistat	345
W6 remote wired humidistat EBERLE HYG6001+ built-in mechanical humidistat	119
W7 remote wired humidistat & thermostat EBERLE HYG7001+built-in mechanical humidistat	129

3. Air temperature:

S standard: +22°C...+42°C	0
T +15°C...+42°C (with antifreeze thermostat)	57

4. Air heating:

S standard: without LPHW (Low Pressure Hot Water)	0
H LPHW, 3.5 kW, without regulation, contact for external thermostat 230V/5A	228
V LPHW, 3.5 kW, with solenoid valve (in standard version – external contact 230V/5A) (with EASY 300 – fully automatic regulation + no current contact)	442
E Electrical heating 2 kW	486

5. LPHW connection:

S standard: N/A (without LPHW)	0
B from the back	0
R from right	0
L from left	0

6. micro LIGHT+

S standard: without Pool Security microLIGHT+	0
L Pool Security microLIGHT+	147

7. Air filter:

S standard: without air filter	0
F Air filter (for model with wall or mobile stand installation: 1-S/M option)	52
C Air filter grid (for model with TTW installation: 1-P/E option)	52

8. Fresh air supply:

S standard: without fresh air supply	0
F adapter, Ø 100 mm, 50 mm length, galvanized	35

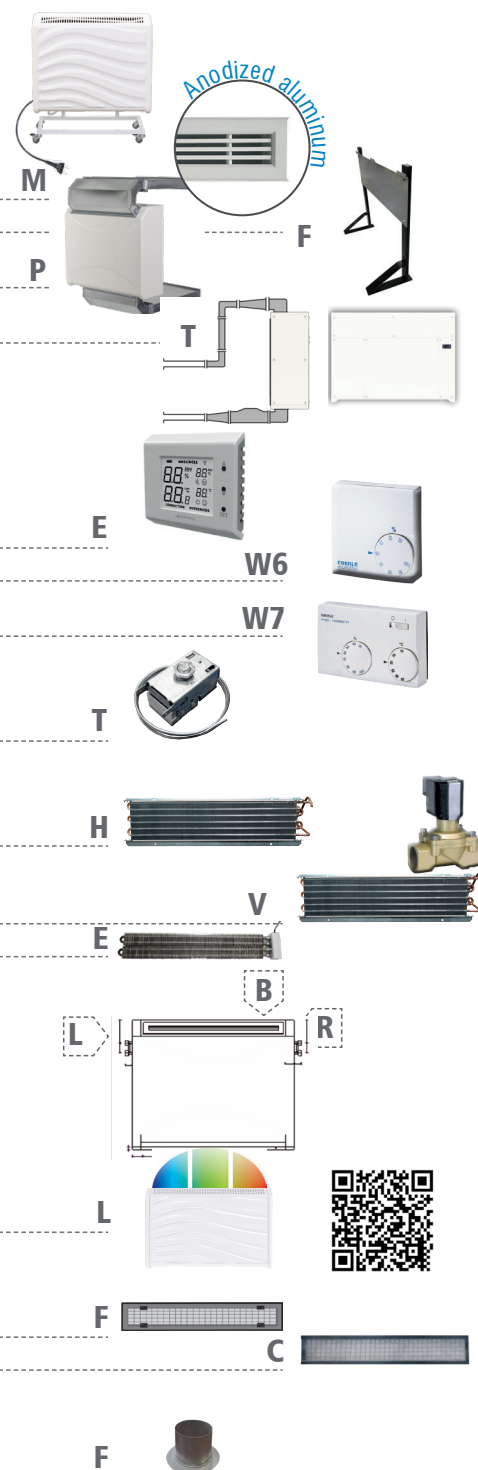

EURO PALETTE packed, FUMIGATED
17.50€/1pc (Depending on the model it is possible to pack more units on EUP (2-6pcs).)

48 l
45 m²

DRY 400 METAL | DRY 400 SILVER

Cover	Cover	Extraction rate	Air flow
DRY 400 METAL	DRY 400 SILVER	(30°C/60% RH - 30°C/80% RH)	
metal	stainless steel	48-78 l/24hrs	600 m ³ /hour



DRY 400M



DRY 400S

642 mm
780 mm
300 mm

SWIMMING POOL DEHUMIDIFIERS



DRY 400M - 1. - 2. - 3. - 4. - 5. - 6. - 7. - 8. - 9.

DRY 400S - - 2. - 3. - 4. - 5. - 6. - 7. - 8. - 9.

Basic equipment:	Model:	Price EXW w/o VAT / EUR/
Dehumidifier, wall console, user's manual installation layout, fixation screws	DRY 400 METAL	3 500
micro COMPRESSOR+ ultra QUIET+ easy INSTALL+ FREE 3 YEARS WARRANTY	DRY 400 SILVER	4 430
1. Color options:		
S standard: silver color 'Tiger'		0
W white (RAL9010) glossy		0
C color selection according to your preference (RAL code)		price on demand
2. Installation:		
S standard: on the wall		0
M mobile stand, 4 wheels, color: silver 'Tiger', white (RAL 9010), 230V EURO plug, 2m		235
F fixed floor stand, color: black RAL9005, 230V EURO plug, 2m		260
3. Control:		
S standard: built-in digital humidistat & thermostat + built-in mechanical humidistat		0
E remote wireless humidistat & thermostat DRY EASY 300 + built-in mechanical humidistat (without built-in digital humidistat & thermostat)		345
W6 remote wired humidistat EBERLE HYG6001 + built-in mechanical humidistat (without built-in digital humidistat & thermostat)		79
W7 remote wired humidistat & thermostat EBERLE HYG7001 + built-in mechanical humidistat (without built-in digital humidistat & thermostat)		88
4. Air temperature:		
S standard: +22°C...+42°C		0
T +15°C...+42°C (with antifreeze thermostat)		57
5. Air heating:		
S standard: without LPHW (Low Pressure Hot Water)		0
H LPHW, 3.5 kW, without regulation (external no current contact)		228
V LPHW, 3.5 kW, fully automatic regulation (with solenoid valve + external no current contact)		442
E Electrical heating 2 kW		486
6. LPHW connection:		
S standard: N/A (without LPHW)		0
B from the back		0
R from right		0
L from left		0
7. micro LIGHT+		
S standard: without Pool Security microLIGHT+		0
L Pool Security microLIGHT+		147
8. Air filter:		
S standard: without air filter		0
F Air filter		52
9. Fresh air supply:		
S standard: without fresh air supply		0
F adapter, Ø 100 mm, 50 mm length, galvanized		35

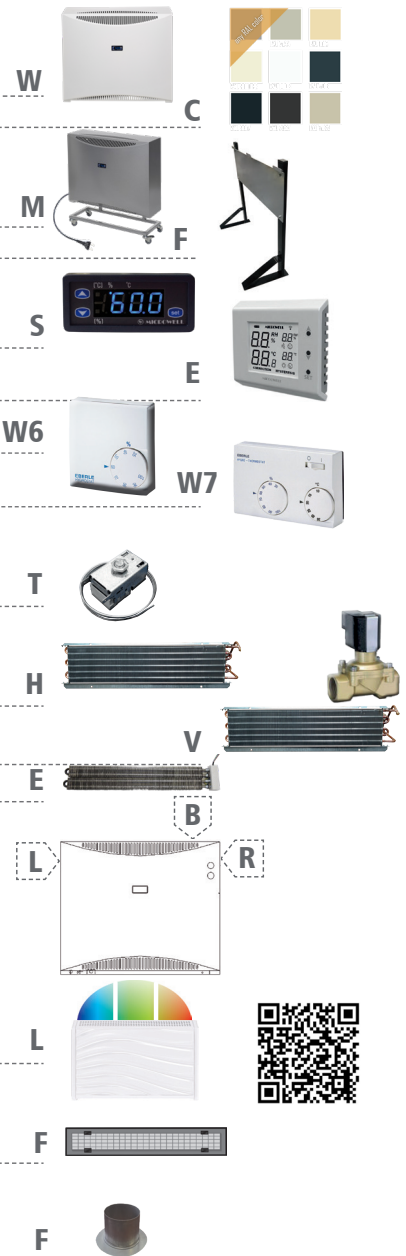

EURO PALETTE packed, FUMIGATED
17.50€/1pc (Depending on the model it is possible to pack more units on EUP (2-6pcs).)



v. 01/2023



Dehumidification, ventilation and heating with one device

- Dehumidify
- Heat
- Ventilate

3 in 1

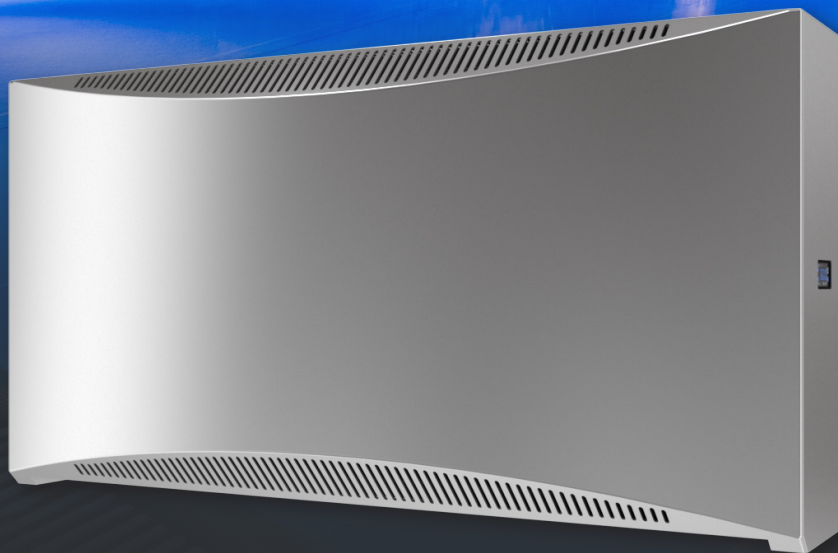

MICROWELL

LEADING EUROPEAN SWIMMING POOL DEHUMIDIFIERS MANUFACTURER

www.microwell.eu

66 l
60 m²

DRY 500 WAVE

Cover	Extraction rate (30°C/60% RH - 35°C/95% RH)	Air flow
plastic (acryl)	66-132 l/24hrs	800 m ³ /hour



DRY 500W - 1. - 2. - 3. - 4. - 5. - 6. - 7. - 8.

Basic equipment: Price EXW w/o VAT /EUR/

Dehumidifier, wall console, user's manual, installation layout, fixation screws

micro COMPRESSOR+ ultra QUIET+ easy INSTALL+



3 740

1. Installation:

S standard: on the wall	0
M mobile stand, 4 wheels, white color (RAL 9010), 230V EURO plug, 2m	265
F fixed floor stand, color: black RAL9005, 230V EURO plug, 2m	280
P through-the-wall INDOOR INSTALLATION (fiberglass cover with TTW ducts set and removable aluminum grills, metal ducts galvanized, insulated)	595
T Premium through-the-wall INDOOR INSTALLATION (metal powder coated cover, wall ducts, removable grills, metal ducts galvanized, insulated)	1 390
E through-the-wall OUTDOOR INSTALLATION (40mm TTW external aluminum and rubber insulation, winter module, condensate tray defrost, -15°C), fiberglass cover	1 480

2. Control:

S standard: built-in mechanical humidistat	0
E remote wireless humidistat & thermostat DRY EASY 300 + built-in mechanical humidistat	345
W6 remote wired humidistat EBERLE HYG6001 + built-in mechanical humidistat	119
W7 remote wired humidistat & thermostat EBERLE HYG7001 + built-in mechanical humidistat	129

3. Air temperature:

S standard: +22°C...+35°C	0
T +15°C...+35°C (with antifreeze thermostat)	57
V +22°C...+42°C (with thermostatic expansion valve)	259
A +15°C...+42°C (T+V)	279
F +5°C...+35°C (with 4-way valve hot gas defrost)	385

4. Air heating:

S standard: without LPHW (Low Pressure Hot Water)	0
H LPHW, 5 kW, without regulation, contact for external thermostat 230V/5A	246
V LPHW, 5 kW, with solenoid valve (in standard version - external contact 230V/5A) (with EASY 300 - fully automatic regulation + no current contact)	458
E Electrical heating 2 kW	507

5. LPHW connection:

S standard: N/A (without LPHW)	0
B from the back	0
R from right	0
L from left	0

6. micro LIGHT+

S standard: without Pool Security microLIGHT+	0
L Pool Security microLIGHT+	147

7. Air filter:

S standard: without air filter	0
F Air filter (for model with wall or mobile stand installation: 1-S/M option)	54
C Air filter grid (for model with TTW installation: 1-P/E option)	67

8. Fresh air supply:

S standard: without fresh air supply	0
F adapter, Ø 100 mm, 50 mm length, galvanized	35

17.50€/1pc

(Depending on the model it is possible to pack more units on EUP (2-6pcs).)

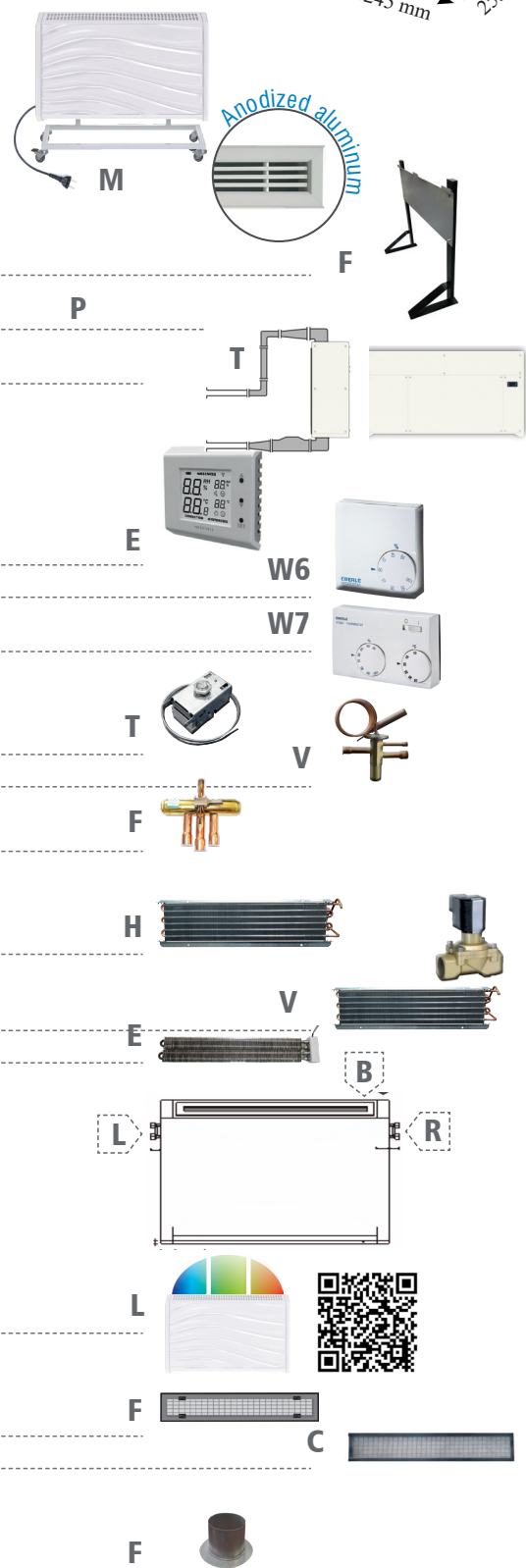

66 l
60 m²

DRY 500 METAL | DRY 500 SILVER

Cover	Cover	Extraction rate	Air flow
DRY 500 METAL	DRY 500 SILVER	(30°C/60% RH - 35°C/95% RH)	
metal	stainless steel	66-132 l/24hrs	800 m ³ /hour

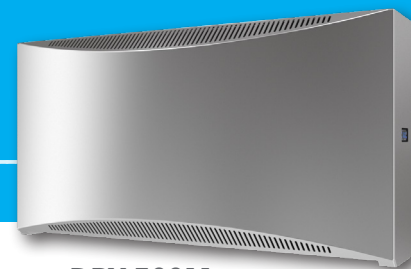

DRY 500M



DRY 500S

SWIMMING POOL DEHUMIDIFIERS



DRY 500M - 1. - 2. - 3. - 4. - 5. - 6. - 7. - 8. - 9.

DRY 500S - - 2. - 3. - 4. - 5. - 6. - 7. - 8. - 9.

Basic equipment:	Model:	Price EXW w/o VAT /EUR/
Dehumidifier, wall console, user's manual, installation layout, fixation screws	DRY 500 METAL	4 450
micro COMPRESSOR+ ultra QUIET+ easy INSTALL+ FREE 3 YEARS WARRANTY	DRY 500 SILVER	5 670

1. Color options:		
S standard: silver color 'Tiger'		0
W white (RAL9010) glossy		0
C Color selection according to your preference (RAL code)		price on demand

2. Installation:		
S standard: on the wall		0
M mobile stand, 4 wheels, color: silver 'Tiger', white (RAL 9010), 230V EURO plug, 2m		265
F fixed floor stand, color: black RAL9005, 230V EURO plug, 2m		280

3. Control:		
S standard: built-in digital humidistat & thermostat + built-in mechanical humidistat		0
E remote wireless humidistat & thermostat DRY EASY 300 + built-in mechanical humidistat (without built-in digital humidistat & thermostat)		345
W6 remote wired humidistat EBERLE HYG6001 + built-in mechanical humidistat (without built-in digital humidistat & thermostat)		79
W7 remote wired humidistat EBERLE HYG7001 + built-in mechanical humidistat (without built-in digital humidistat & thermostat)		88

4. Air temperature:		
S standard: +22°C...+35°C		0
T +15°C...+35°C (with antifreeze thermostat)		57
V +22°C...+42°C (with thermostatic expansion valve)		259
A +15°C...+42°C (T+V)		279
F +5°C...+35°C (with 4-way valve hot gas defrost)		385

5. Air heating:		
S standard: without LPHW (Low Pressure Hot Water)		0
H LPHW, 5 kW, without regulation (external no current contact)		246
V LPHW, 5 kW, fully automatic regulation (with solenoid valve + external no current contact)		458
E Electrical heating 2 kW		507

6. LPHW connection:		
S standard: N/A (without LPHW)		0
B from the back		0
R from right		0
L from left		0

7. micro LIGHT+		
S standard: without Pool Security microLIGHT+		0
L Pool Security microLIGHT+		147

8. Air filter:		
S standard: without air filter		0
F Air filter		54

9. Fresh air supply:		
S standard: without fresh air supply		0
F adapter, Ø 100 mm, 50 mm length, galvanized		35

W



M



S



W6



E



W7

T



V

F



H



V

E



B

L

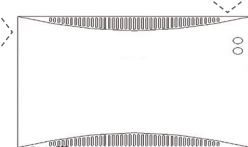

R

L



F



F



EURO PALLETTE packed, FUMIGATED
17.50€/1pc (Depending on the model it is possible to pack more units on EUP (2-6pcs).)

90l
90 m²

DRY 800 WAVE

120l
120 m²

DRY 1200 WAVE

Cover	Extraction rate (30°C/60% RH - 35°C/95% RH)	Air flow	Extraction rate (30°C/60% RH - 35°C/95% RH)	Air flow
plastic (acryl) white color	90-180 l/24hrs	1100 m ³ /hour	120-240 l/24hrs	1200 m ³ /hour

DRY 800W - 1. - 2. - 3. - 4. - 5. - 6. - 7. - 8.

DRY 1200W - 1. - 2. - 3. - 4. - 5. - 6. - 7. - 8.

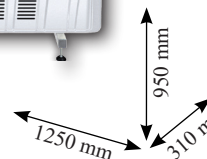

Basic equipment:	Model:	Price EXW w/o VAT /EUR/
Dehumidifier, floor feet, user's manual	DRY 800 WAVE	4 900
	DRY 1200 WAVE	5 300

micro COMPRESSOR + ultra QUIET + easy INSTALL +



1. Installation:

S standard: on the floor	0
M on the wall (floor feet + wall console)	135

2. Control:

Unit comes from factory without control, please select from below options:

E remote wireless humidistat & thermostat DRY EASY 300	
F remote wired digital humidistat & thermostat	243
W6 remote wired humidistat EBERLE HYG6001	79
W7 remote wired humidistat EBERLE HYG7001	88

3. Air temperature:

S standard: +22°C...+35°C	0
T +15°C...+35°C (with antifreeze thermostat)	57
B +35°C...+42°C (with solenoid bypass and compressor cooling)	270

4. Air heating:

S standard: without LPHW (Low Pressure Hot Water)	0
H LPHW, 7 kW, without regulation (external no current contact)	345
V LPHW, 7 kW, fully automatic regulation (with solenoid valve + external no current contact)	590
E Electrical heating 2.5 kW	570

5. LPHW connection:

S standard: N/A (without LPHW)	0
B from the back	0
R from right	0

6.

S standard: without Pool Security microLIGHT+	0
L Pool Security microLIGHT+	147

7. micro LIGHT+

S standard: without air filter	0
F Air filter (for model with wall or mobile stand installation: 1-S/M option)	54
C Air filter grid (for model with TTW installation: 1-P option)	54

8. Fresh air supply:

S standard: without fresh air supply	0
F adapter, Ø 100 mm, 50 mm length, galvanized	35

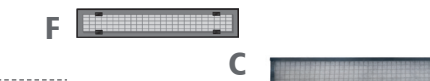
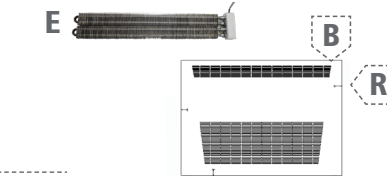
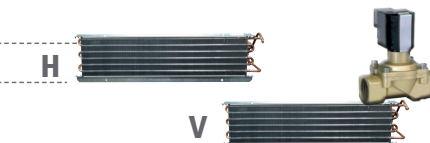
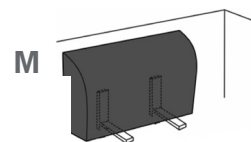

EURO PALETTE packed, FUMIGATED
17.50€/1pc (Depending on the model it is possible to pack more units on EUP (2-6pcs).)

90L
90 m²

DRY 800 METAL

120L
120 m²

DRY 1200 METAL

Cover	Extraction rate (30°C/60% RH - 35°C/95% RH)	Air flow
metal	90-180 l/24hrs	1100 m ³ /hour

Extraction rate (30°C/60% RH - 35°C/95% RH)	Air flow
120-240 l/24hrs	1200 m ³ /hour

DRY 800M - 1. - 2. - 3. - 4. - 5. - 6. - 7. - 8. - 9.

DRY 1200M - 1. - 2. - 3. - 4. - 5. - 6. - 7. - 8. - 9.

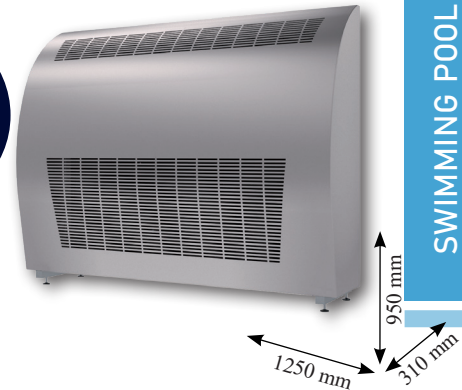
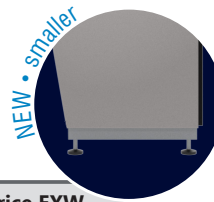

SWIMMING POOL DEHUMIDIFIERS

Basic equipment:

Model:

Price EXW
w/o VAT /EUR/

Dehumidifier, floor feet, user's manual

DRY 800 METAL

5 390

micro COMPRESSOR+ ultra QUIET+ easy INSTALL+



DRY 1200 METAL

5 840

1. Color options:

S standard: silver color „Tiger“	0
W white (RAL9010) glossy	0
C color selection according to your preference (RAL code)	price on demand

2. Installation:

S standard: on the floor	0
M on the wall (floor feet + wall console)	135
P through-the-wall INDOOR INSTALLATION (main chassis cover from galvanized metal powder coated RAL9010 with AIR IN from the back, AIR OUT to the back/to the top, including the through-the-wall ducts set and removable grills, insulated from the inside)	325
E through-the-wall OUTDOOR INSTALLATION (40mm TTW external aluminum and rubber insulation, winter module, condensate tray defrost, -15°C)	895

3. Control:

S standard: built-in digital humidistat & thermostat + built-in mechanical humidistat	0
E remote wireless humidistat & thermostat DRY EASY 300 + built-in mechanical humidistat (without built-in digital humidistat & thermostat)	345
W6 remote wired humidistat EBERLE HYG6001 + built-in mechanical humidistat (without built-in digital humidistat & thermostat)	79
W7 remote wired humidistat & thermostat EBERLE HYG7001+ built-in mechanical humidistat (without built-in digital humidistat & thermostat)	88

4. Air temperature:

S standard: +22°C...+35°C	0
T +15°C...+35°C (with antifreeze thermostat)	57
B +35°C...+42°C (with solenoid bypass and compressor cooling)	270

5. Air heating:

S standard: without LPHW (Low Pressure Hot Water)	0
H LPHW, 7 kW, without regulation (external no current contact)	345
V LPHW, 7 kW, fully automatic regulation (with solenoid valve + external no current contact)	590
E Electrical heating 2.5 kW	570

6. LPHW connection:

S standard: N/A (without LPHW)	0
B from the back	0
R from right	0

7. micro LIGHT+

S standard: without Pool Security microLIGHT+	0
L Pool Security microLIGHT+	147

8. Air filter:

S standard: without air filter	0
F Air filter (for model with wall or floor installation: 2-S/M option)	54
C Air filter grid (for model with TTW installation: 2-P/E option)	67

9. Fresh air supply:

S standard: without fresh air supply	0
F adapter, Ø 100 mm, 50 mm length, galvanized	35

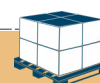
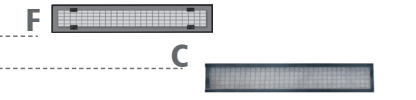
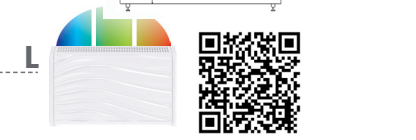
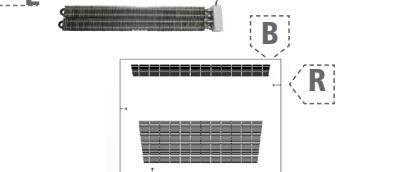
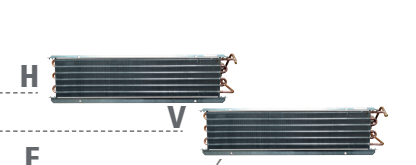
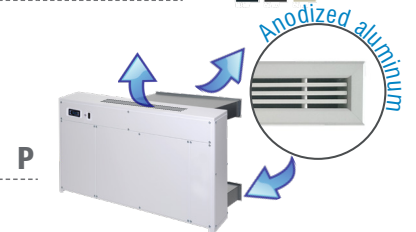

EURO PALETTE packed, FUMIGATED
17.50€/1pc (Depending on the model it is possible to pack more units on EUP (2-6pcs).)



DRY Salt+ Sulphur+



Models:

Price EXW /*
w/o VAT /EUR/

DRY 300 Salt+ Sulphur+	880
DRY 400 Salt+ Sulphur+	880
DRY 500 Salt+ Sulphur+	1 060
DRY 800 Salt+ Sulphur+	1 240
DRY 1200 Salt+ Sulphur+	1 240

/* Brutto Price List price.
Distributor rebates apply.

Basic description:

Special treatment to withstand high concentrations of salt, sulphur and chlorine. Designed for natural salt/sulphur water spa, salt caves or alternatives with natural water spring spa that contains high concentrations of salt or sulphur. This special treatment can be applied also to high chlorine concentration pools where it provides higher resistance thereby longer livelihood of the device. Treatment is also designed to avoid formation of sulphuric acid (H₂SO₄).

- Natural spa
- Salt caves
- Chlorine
- Sulphur

- Extra zinc
- Extra LCE Epoxy coating
- Extra powder coating enamel at 180°
- Extra brex insulation



Special treatment to withstand high concentration
of **SALT, SULPHUR and CHLORINE.**

Suitable for natural salt/sulfur
water spa, salt caves and
pools with high concentration
of salt, sulfur or chlorine.



DRY Salt+ Sulphur+

**PROLONGS
LIVELIHOOD OF
YOUR DEHUMIDIFIER**

IN EXTREME CONDITIONS



Applicable to
all models of
pool dehu-
midifiers

**8x
more
reliable use**

32 l
30 m²

DRY 300 DUCT

Cover	Extraction rate (30°C/60% RH - 35°C/95% RH)	Air flow
metal	32-63 l/24hrs	500 m ³ /hour, 200 Pa



DRY 300D - 1. - 2. - 3. - 4. - 5. - 6.

Basic equipment: Dehumidifier, wall console, fixation screws, user's manual, installation layout **Price EXW w/o VAT /EUR/**

3 490

micro COMPRESSOR+ micro CONTROL+ **FREE 3 YEARS WARRANTY**

1. Control:

S standard: built-in digital humidistat & thermostat + built-in mechanical humidistat	0
E remote wireless humidistat & thermostat DRY EASY 300 + built-in mechanical humidistat (without built-in digital humidistat & thermostat)	345
W6 remote wired humidistat EBERLE HYG6001 + built-in mechanical humidistat (without built-in digital humidistat & thermostat)	79
W7 remote wired humidistat & thermostat EBERLE HYG7001+built-in mechanical humidistat (without built-in digital humidistat & thermostat)	88



2. Air temperature:

S standard: +22°C...+35°C	0
T +15°C...+35°C (with antifreeze thermostat)	57
V +22°C...+42°C (with thermostatic expansion valve)	259
A +15°C...+42°C (T+V)	279
F +5°C...+35°C (with 4-way valve hot gas defrost)	385

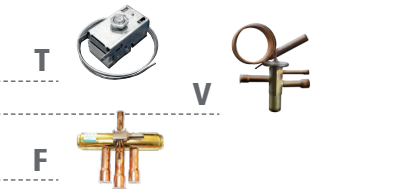

3. Air heating:

S standard: without LPHW (Low Pressure Hot Water)	0
H LPHW, 3.5 kW, without regulation (external no current contact)	246
V LPHW, 3.5 kW, fully automatic regulation (with solenoid valve + external no current contact)	458
E Electrical heating, 2 kW	486

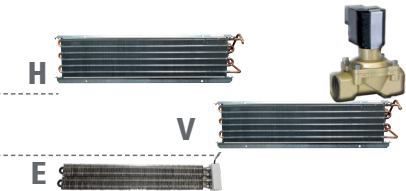

4. LPHW connection:

S standard: N/A (without LPHW)	0
B from the back	0
R from right	0



5. Air filter console:

S standard: without air filter console	0
C Air filter console 5C, with removable cartouche	150



6. Air ducting connection:

S1 Air inlet from bottom	0
S2 Air outlet from the top	0
F1 Air inlet from the front	80
F2 Air outlet from the front	80

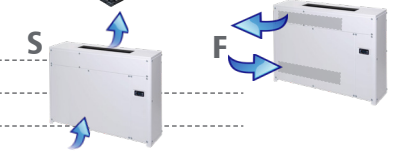

EURO PALLETTE packed, FUMIGATED
17.50€/1pc (Depending on the model it is possible to pack more units on EUP (2-6pcs).)

Find more **ACCESSORIES** on pages 59-63.

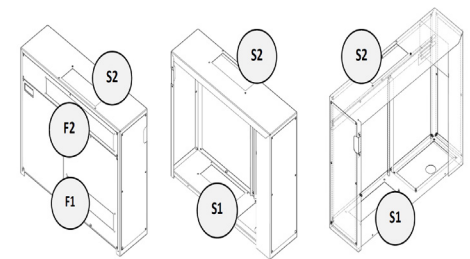

43 l
40 m²

DRY 400 DUCT

Cover	Extraction rate (30°C/60% RH - 35°C/95% RH)	Air flow
metal	43-78 l/24hrs	500 m ³ /hour, 200 Pa



DRY 400D - 1. - 2. - 3. - 4. - 5. - 6.

Basic equipment: Dehumidifier, wall console, fixation screws, user's manual, installation layout **Price EXW w/o VAT /EUR/**

micro COMPRESSOR+ micro CONTROL+ **FREE 3 YEARS WARRANTY**

3 880

1. Control:	
S standard: built-in digital humidistat & thermostat + built-in mechanical humidistat	0
E remote wireless humidistat & thermostat DRY EASY 300 + built-in mechanical humidistat (without built-in digital humidistat & thermostat)	345
W6 remote wired humidistat EBERLE HYG6001 + built-in mechanical humidistat (without built-in digital humidistat & thermostat)	79
W7 remote wired humidistat & thermostat EBERLE HYG7001+built-in mechanical humidistat (without built-in digital humidistat & thermostat)	88
2. Air temperature:	
S standard: +22°C...+42°C	0
T +15°C...+42°C (with antifreeze thermostat)	57
3. Air heating:	
S standard: without LPHW (Low Pressure Hot Water)	0
H LPHW, 3.5 kW, without regulation (external no current contact)	246
V LPHW, 3.5 kW, fully automatic regulation (with solenoid valve + external no current contact)	458
E Electrical heating, 2 kW	486
4. LPHW connection:	
S standard: N/A (without LPHW)	0
B from the back	0
R from right	0
5. Air filter console:	
S standard: without air filter console	0
C Air filter console 5C, with removable cartouche	150
6. Air ducting connection:	
S1 Air inlet from bottom	0
S2 Air outlet from the top	0
F1 Air inlet from the front	80
F2 Air outlet from the front	80

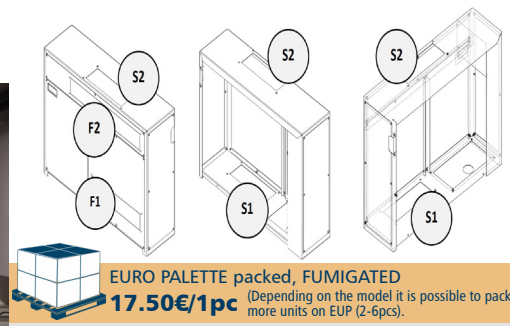
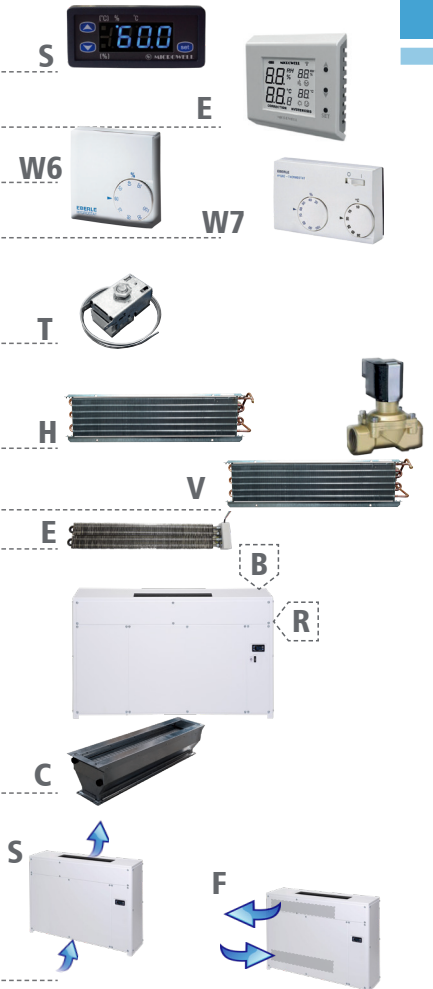

52 l
50 m²

DRY 500 DUCT

Cover	Extraction rate (30°C/60% RH - 35°C/95% RH)	Air flow
metal	52-132 l/24hrs	1000 m ³ /hour, 200 Pa



DRY 500D - 1. - 2. - 3. - 4. - 5. - 6.

Basic equipment: Dehumidifier, wall console, fixation screws, user's manual, installation layout **Price EXW w/o VAT /EUR/**

4 570

micro COMPRESSOR+ micro CONTROL+ **FREE 3 YEARS WARRANTY**

1. Control:

S standard: built-in digital humidistat & thermostat + built-in mechanical humidistat	0
E remote wireless humidistat & thermostat DRY EASY 300 + built-in mechanical humidistat (without built-in digital humidistat & thermostat)	345
W6 remote wired humidistat EBERLE HYG6001 + built-in mechanical humidistat (without built-in digital humidistat & thermostat)	79
W7 remote wired humidistat & thermostat EBERLE HYG7001+built-in mechanical humidistat (without built-in digital humidistat & thermostat)	88



2. Air temperature:

S standard: +22°C...+35°C	0
T +15°C...+35°C (with antifreeze thermostat)	57
V +22°C...+42°C (with thermostatic expansion valve)	259
A +15°C...+42°C (T+V)	279
F +5°C...+35°C (with 4-way valve hot gas defrost)	385

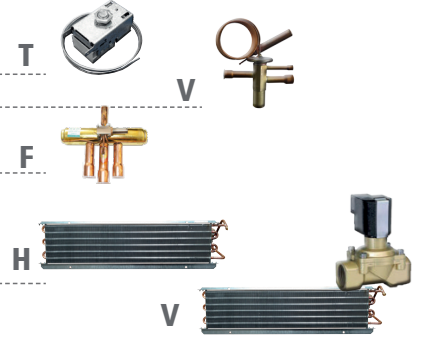

3. Air heating:

S standard: without LPHW (Low Pressure Hot Water)	0
H LPHW, 5 kW, without regulation (external no current contact)	246
V LPHW, 5 kW, fully automatic regulation (with solenoid valve + external no current contact)	458
E Electrical heating, 2 kW	486



4. LPHW connection:

S standard: N/A (without LPHW)	0
B from the back	0
R from right	0



5. Air filter console:

S standard: without air filter console	0
C Air filter console 5C, with removable cartouche	170

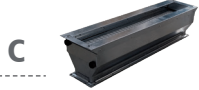

6. Air ducting connection:

S1 Air inlet from bottom	0
S2 Air outlet from the top	0
F1 Air inlet from the front	80
F2 Air outlet from the front	80

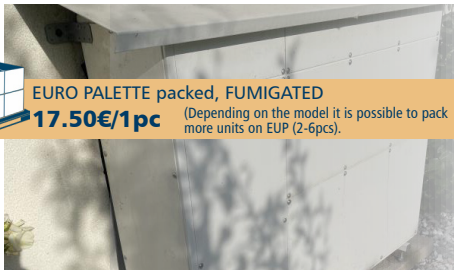
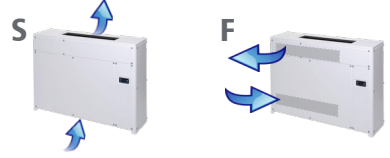

EURO PALETTE packed, FUMIGATED
17.50€/1pc (Depending on the model it is possible to pack more units on EUP (2-6pcs).)

Find more ACCESSORIES on pages 59-63.

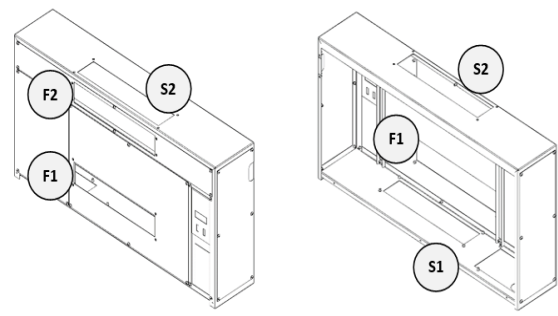

88l 80 m ²	DRY 800 DUCT	112l 110 m ²	DRY 1200 DUCT
Cover	Extraction rate (30°C/60% RH - 35°C/95% RH)	Air flow	
metal	88-180 l/24hrs	1100 m ³ /hour, 170 Pa	
			Extraction rate (30°C/60% RH - 35°C/95% RH)
			Air flow
			112-240 l/24hrs
			1200 m ³ /hour, 145 Pa



DRY 800D - 1. - 2. - 3. - 4. - 5. - 6.6.
DRY 1200D - 1. - 2. - 3. - 4. - 5. - 6.6.

Basic equipment:	Model:	Price EXW w/o VAT /EUR/
Dehumidifier, floor feet, fixation screws, user's manual, installation layout	DRY 800 DUCT	5 900
	DRY 1200 DUCT	6 600
1. Control:		
S standard: standard: built-in digital humidistat & thermostat + built-in mechanical humidistat		0
E remote wireless humidistat & thermostat DRY EASY 300 + built-in mechanical humidistat (without built-in digital humidistat & thermostat)		345
W6 remote wired humidistat EBERLE HYG6001 + built-in mechanical humidistat (without built-in digital humidistat & thermostat)		79
W7 remote wired humidistat & thermostat EBERLE HYG7001+built-in mechanical humidistat (without built-in digital humidistat & thermostat)		88
2. Air temperature:		
S standard: +22°C...+35°C		0
T +15°C...+35°C (with antifreeze thermostat)		57
B +35°C...+42°C (with solenoid bypass and compressor cooling)		270
3. Air heating:		
S standard: without LPHW (Low Pressure Hot Water)		0
H LPHW, 7 kW, without regulation (external no current contact)		345
V LPHW, 7 kW, fully automatic regulation (with solenoid valve + external no current contact)		590
E Electrical heating 2.5 kW		570
4. LPHW connection:		
S standard: N/A (without LPHW)		0
B from the back		0
R from right		0
5. Air filter console:		
S standard: without air filter console		0
C Air filter console 5C, with removable cartouche		250
6. Air ducting connection:		
A1 Air inlet from the back		0
A2 Air outlet from the back		0
B1 Air inlet from the front		80
B2 Air outlet from the front		80
C1 Air inlet from the bottom		80
C2 Air outlet from the top		0

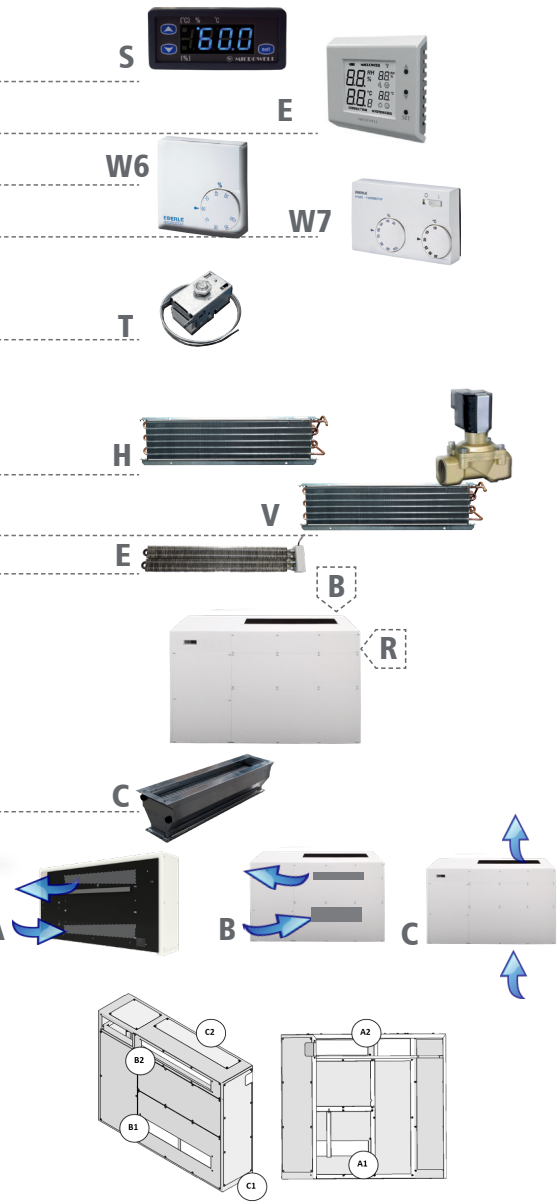

EURO PALETTE packed, FUMIGATED
17.50€/1pc (Depending on the model it is possible to pack more units on EUP (2-6pcs).)

67 l 60 m²			134 l 120 m²	
SIREN Eco mono			SIREN Eco due	
Cover	Extraction rate <small>(30°C/60% RH - 35°C/95% RH)</small>	Air flow	Extraction rate <small>(30°C/60% RH - 35°C/95% RH)</small>	Air flow
plastic (acryl) white color	67-130 l/24hrs	1000 m ³ / hour	134-260 l/24hrs	2000 m ³ /hour

SIREN Eco mono - 1. - 2. - 3. - 4. - 5.

SIREN Eco due - 1. - 2. - 3. - 4. - 5.

Basic equipment:	Model:	Price EXW w/o VAT /EUR/
ceiling unit, compressor unit, remote control, wall consoles for compressor unit, ceiling lifting mechanism, Bluetooth speaker, LED light, hot gas defrost, user's manual	SIREN Eco mono	8 300
2x ceiling unit, compressor unit, remote control, wall consoles for compressor unit, ceiling lifting mechanism, Bluetooth speaker, LED light, hot gas defrost, user's manual	SIREN Eco due	13 900

micro LIGHT+ micro ENERGY+ micro SAFETY+ FREE 3 YEARS WARRANTY
micro COMPRESSOR+ ultra QUIET+

1. Ceiling unit installation:	
S concrete ceiling	0
B wooden beam	0
2. Cable length:	
S 10m	0
M 20m	70
L 30m	90
3. Copper pipes:	
S standard: without copper pipes	0
A Insulated copper pipes D10 (3/8" x 1)+D12 (1/2" x 1) - 50m package /Rebate not applicable. <i>This is the final purchase price./</i>	510
4. Condensate pump:	
S standard: built-in condensate pump, vertical discharge 1~8m, horizontal discharge 21~0m	0
S external condensate pump, vertical suction up to 3m, horizontal suction up to 10m, vertical discharge 1~8m, horizontal discharge 21~0	40
A additional condensate pump Sauermann – condensing, with tank 2l, 500l/h, max. 5m	75
5. Condensate hose:	
S standard: with 1m condensate hose 6mm internal / 9mm external flexible	0
A Condensate hose No. 7100 with metal spiral 16mm – 1 standard meter	0.95

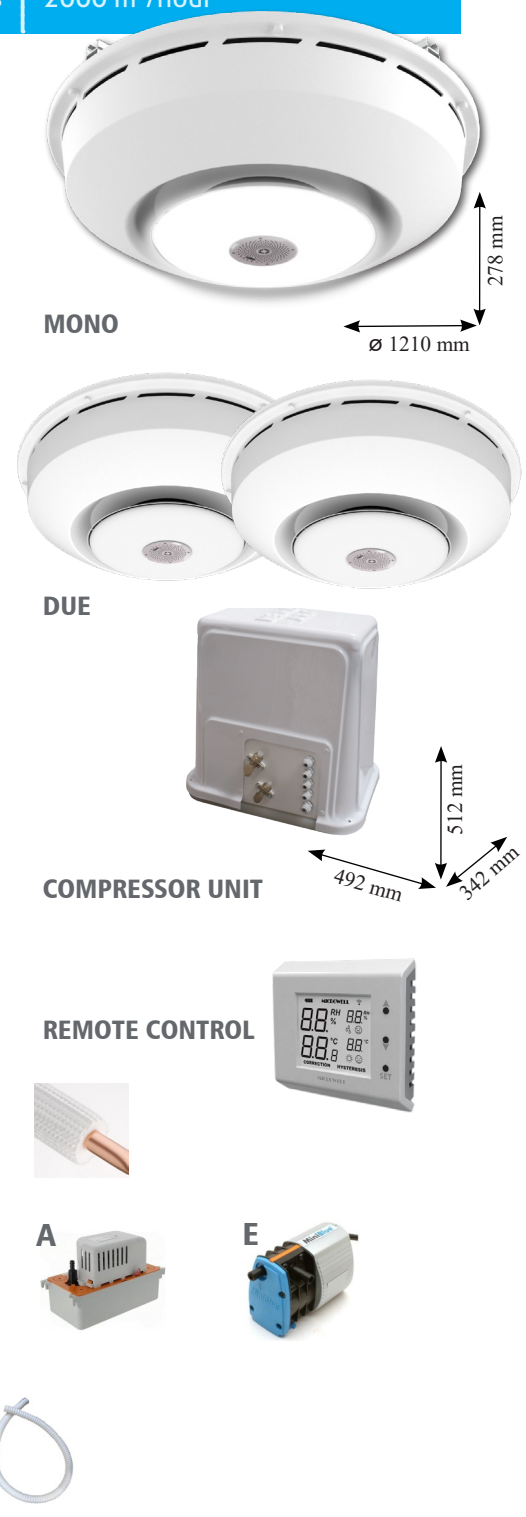

EURO PALETTE packed, FUMIGATED
17.50€/1pc (Depending on the model it is possible to pack more units on EUP (2-6pcs).)





Perfect dehumidification without limits

MICROWELL SIREN ECO is the ultimate superstar, the first ceiling swimming pool dehumidifier in the world. Combining all what Microwell technology has to offer, SIREN ECO is an intelligent and visually captivating solution of paramount performance, setting a new tide in the industry.

As the first round ceiling dehumidifier it is constructed as dual split unit, capable of all round and thorough humidity extraction.

**SPLIT
system**

**Wireless
control**

DEHUMIDIFIER



microLIGHT+



LOUDSPEAKER



LED LAMP



Siren Eco

up to 120 m² pool surface

HORIZON

DRY COMING SOON

GO HORIZONTAL

- Concealed
- Made for installation in false ceiling
- Air flow up to **2.700m³/h**
- External pressure up to **300Pa**
- Operational point of **1.500m³/h** with **200Pa**
- Connection to dia 315mm air ducting
- Extraction rate up to **150kg/day** A30RH70
- 465mm height
- G3 filter
- 1phase / 220-240V

**DUCT
system**

Only
465mm
height

NEW

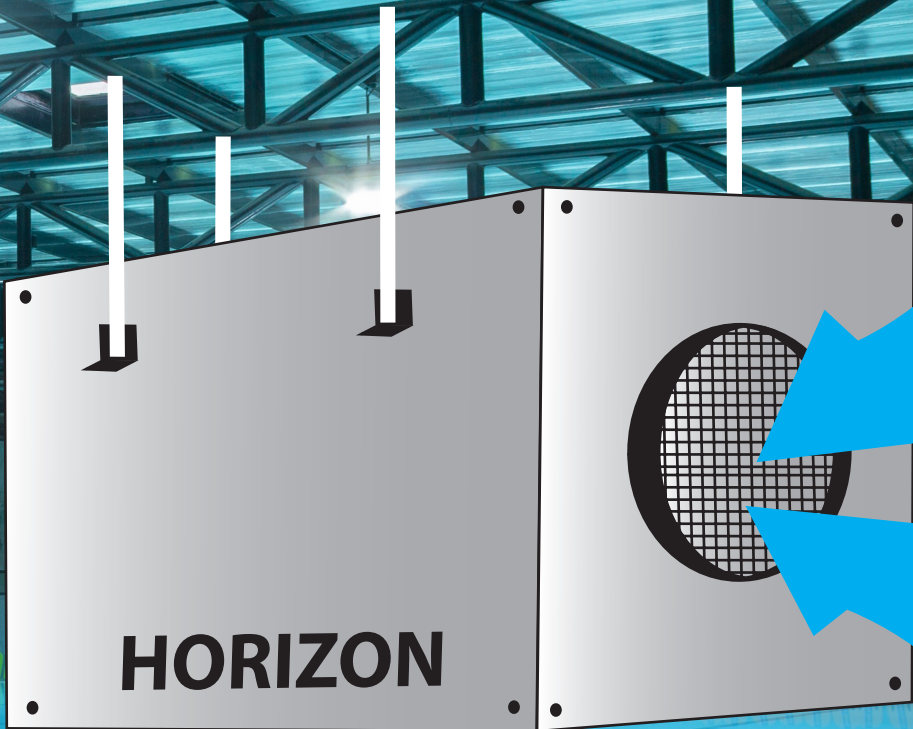

22 l
90 m³/*

DRY 300 GALLERY

38 l
135 m³/*

DRY 400 GALLERY

Cover	Extraction rate (25°C, 50%RH)	Air flow	Extraction rate (25°C, 50%RH)	Air flow
wooden wardrobe construction	22 l/24hrs	550 m ³ /h	38 l/hrs	600 m ³ /h



DRY 300G - 1. - 2. - 3.

DRY 400G - 1. - 2. - 3.

Basic equipment:	Model:	Price EXW w/o VAT /EUR/
Fully mobile dehumidifier, 20 liter condensation tank, mobile cart, water tank drainage, float switch, user's manual micro COMPRESSOR+	DRY 300 GALLERY	3 290
	DRY 400 GALLERY	3 590

1. Control:		
S standard: built-in humidistat & thermostat + built-in mechanical humidistat		0
E remote wireless humidistat & thermostat DRY EASY 300 + built-in mechanical humidistat (without built-in digital humidistat & thermostat)		345
2. Air temperature:		
S standard: +15°C...+35°C		0
F +5°C...+35°C (with 4-way valve hot gas defrost)		246
3. Air filter:		
S standard: without air filter		0
F Air filter		56

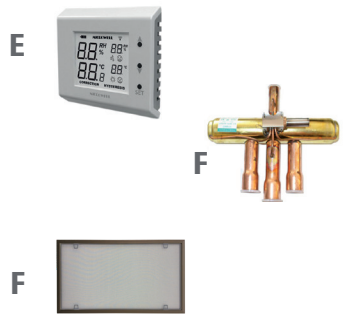

Basic equipment includes:

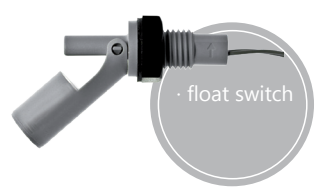

 EURO PALETTE packed, FUMIGATED
17.50€/1pc (Depending on the model it is possible to pack more units on EUP (2-6pcs).)



Suitable for small exhibition spaces

Picture is illustratory.

40 l day	T40 TE40		90 l day	T90 TE9		120 l day	T120 TE120	
Cover	Operating range	Nominal air delivery	Operating range	Nominal air delivery	Operating range	Nominal air delivery		
metal	0°C - 35°C	500 m³/hour	0°C - 35°C	1100 m³/hour	0°C - 35°C	1500 m³/hour		



ENERGY CONSUMPTION
from **650W**



/* Final prices. Discount does not apply on these items.

Basic equipment:	Price EXW /* w/o VAT /EUR/
Fully mobile dehumidifier, user's manual, EU plug, on-off	
Designed for drying up buildings, new construction sites, warehouses, as well as non-heated and flooded buildings with high level of humidity.	
easy INSTALL+	
T40	1 250
TE40	1 290
with Electrical heater, 2 kW	
T90	1 800
TE90	1 990
with Electrical heater, 2 kW	
T120	2 100
TE120	2 250
with Electrical heater, 2 kW	

Additional equipment:	Price EXW /* w/o VAT /EUR/
A UK plug conversion	20
B Float switch	90
C External hygostat	100
D 20l bucket with mobile base (4 wheels)	85

T40 | TE40

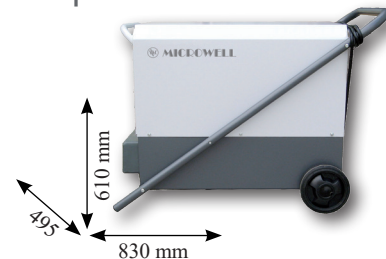

T90 | TE90



T120 | TE120

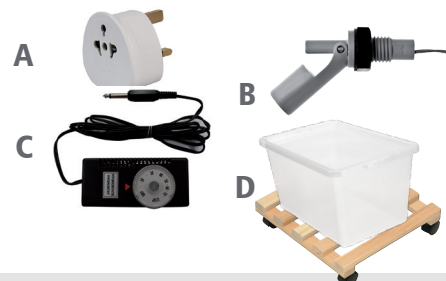

Picture is illustratory.

Suitable for construction sites, buildings, rooms after reconstruction



EURO PALETTE packed, FUMIGATED
17.50€/1pc (Depending on the model it is possible to pack more units on EUP (2-6pcs).)

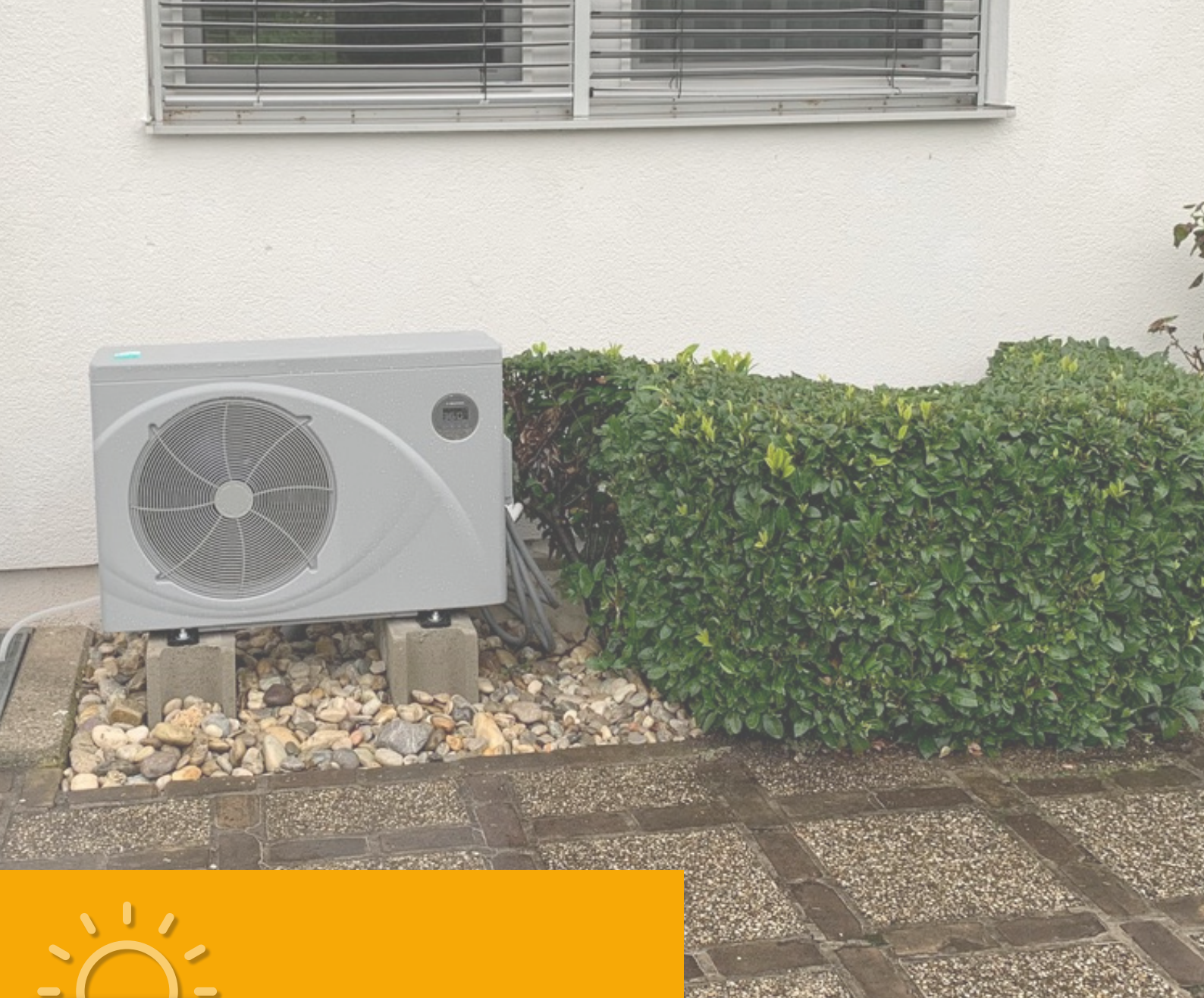

Heat pumps

ON-OFF & INVERTER models

Available in COMPACT & SPLIT versions

For seasonal, or full year using

Variety of models to fit every pool.

Excellent craftsmanship and experience.

MICROWELL HP range of swimming pool heat pumps are operating on the principle of renewable energy, designed for continuous and stable production of water heating or cooling.

Their exceptional efficiency, low environment impact and low costs are the result of superior technology, putting them at the industry's forefront.

MICROWELL HP Line 2023			Pool capacity (cover/ no cover)	(A27/W27, RH80%)			Air temperature (WINTER modification)	Cooling capacity (A35/W28) (HP BLACK -A43/W35)	Water flow	Power supply	El. connection / protection	Titanium	Acoustic pressure level (1m/10m)	Dimensions netto (W x H x D) condensing unit	Weight netto
				Heat capacity	Power cons.	COP									
Model	Version	m ³	kW	kW	COP	°C	kW	m ³ /h	V AC/ Ph	mm ²	Grade & Surface /*	dB(A)	mm	kg	
FULL YEAR or SEASONAL - ON-OFF	 HP1000 GREEN		45 / 30	9.2	1.4	6.1	0...+43 (-15...+43)	4.9	4	230/1	3x25/ C16A	Gr 1 ASTM265 0.42 m ²	46/29	910x620x360	39
	 HP1400 GREEN		55 / 40	12.3	1.8	6.0	0...+43 (-15...+43)	6.2	5.3	230/1	3x25/ C16A	Gr 1 ASTM265 0.6 m ²	52/32	1000x665x385	49
	 HP1700 GREEN		70 / 50	16.2	2.4	6.0	0...+43 (-15...+43)	8.3	7.1	230/1	3x4/ C20A	Gr 1 ASTM265 0.72 m ²	54/35	1000x665x385	56
	 HP2300 INVENTOR (3f)		80 / 60	23	3.59	6.4	-5...+40 (-15...+40) (-5...+60)	20.1	8-10	400/3	5x25/ C10A	Gr 1 ASTM265 0.95 m ²	56/38	942x1550x360 (942x1250x360)	118
	 HP2800 INVENTOR (3f)		120 / 80	28.4	4.44	6.4	-5...+40 (-15...+40) (-5...+60)	25.0	8-12	400/3	5x25/ C10A	Gr 1 ASTM265 1.2 m ²	56/38	942x1550x360 (942x1250x360)	120
SEASONAL - INVERTER	 HP900 BLACK Inverter		40 / 15-30	9.0	0.2~1.6	11~5.8	-7...+43	2.7	2.7	230/1	3x25/ C16A	Gr 1 ASTM265 0.4 m ²	49/40	932x609x377	43
	 HP1100 BLACK Inverter		45 / 25-35	11.5	0.2~1.9	11~5.9	-7...+43	3.5	3.3	230/1	3x25/ C16A	Gr 1 ASTM265 0.5 m ²	50/41	932x609x377	44
	 HP1500 BLACK Inverter		65 / 35-50	15.0	0.3~2.7	11~5.7	-7...+43	5.4	4.4	230/1	3x25/ C16A	Gr 1 ASTM265 0.6 m ²	53/43	1015x766x427	61
FULL YEAR - INVERTER	 HP1100 GREEN Inverter Pro		65 / 30	10.8	1.7-0.8	6.4-14	-15...+43	4.5	3-5	230/1	3x25/ C16A	Gr 1 ASTM265 0.52 m ²	42/29	990x657x340	49
	 HP1500 GREEN Inverter Pro		80 / 40	15.0	2.3-1.0	6.5-15	-15...+43	6.7	5-7	230/1	3x25/ C16A	Gr 1 ASTM265 0.7 m ²	45/24	990x657x340	52
	 HP1700 GREEN Inverter Pro		95 / 45	17.0	2.6-1.1	6.5-15	-15...+43	7.5	6-8	230/1	3x4/ C20A	Gr 1 ASTM265 0.80 m ²	46/33	954x648x429	63
	 HP2100 GREEN Inverter Pro		105 / 50	21.0	3.3-1.4	6.4-14.8	-15...+43	9.5	8-10	230/1	3x4/ C20A	Gr 1 ASTM265 0.9 m ²	46/33	954x748x429	68
	 HP2700 GREEN Inverter Pro (3f)		135 / 60	27.5	4.2-1.8	6.5-15	-15...+43	11.9	10-12	400/3	5x25/ C10A	Gr 1 ASTM265 1.0 m ²	48/34	1084x948x429	93
FULL YEAR PREMIUM	 HP2400 PREMIUM (3f)		80 / 60	24.4	3.51	6.9	-15...+40 (-5...+60)	21.7	8-10	400/3	5x25/ C10A	Gr 1 ASTM265 1.2 m ²	56/38	942x1550x360 (942x1250x360)	118
	 HP3000 PREMIUM (3f)		120 / 80	30.1	4.34	6.9	-15...+40 (-5...+60)	26.8	8-12	400/3	5x25/ C10A	Gr 1 ASTM265 1.4 m ²	56/38	942x1550x360 (942x1250x360)	120
COMMERCIAL - INVERTER	 iMax 60 (3f)		125-260	60.2	5.7	10.5	-10...+43 (0...+55)	26.8	20-25	400/3	-	Gr 1 ASTM265 3.0 m ²	61/41	1000x1260x1110	212
	 iMax 110 (3f)		250-520	115.0	11.5	10.0	-10...+43 (0...+55)	53.5	40-50	400/3	-	Gr 1 ASTM265 6.0 m ²	64/44	2100x1280x1090	459

COMPACT / SPLIT

COMPACT

Notes: The manufacturer reserves the right to change the parameters without notice.

/* **Grade 1** titanium is the first of commercially available pure titanium grades. It is the softest and most ductile type of titanium material. It possesses the greatest **formability** and **excellent corrosion resistance**. Grade 1 titanium will ensure long happy life of your heat pump and will also prevent possible transport damage due to its **high impact toughness**.

 **REGULATION OVER Wi-Fi**
ANDROID and IOS APP available for free

Download on the  **App Store**

GET IT ON  **Google Play**

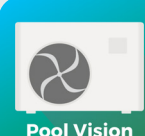
 **Pool Vision**

 **Smart Life**

 **Smart INVERTER**

 **Black Smart App**

INVISIBLE HEAT PUMP FOR WHIRLPOOL

ENJOY YOUR BELOVED WHIRLPOOL BATH
WITHOUT WORRYING ABOUT ENERGY BILL



-15°C +40°C
AMBIENT WATER

INVISIBLE SET UP SPLIT

WATER HEAT EXCHANGER
INSIDE JACUZZI CHASSIS

HEAT PUMP UP TO
30 METERS AWAY

30 M



There is no additional noise, vibration or visual disturbance since the split heat pump can be placed as far as 30 meters away from the jacuzzi.

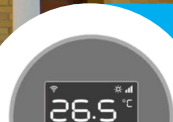

An intuitive control panel with full integration into the jacuzzi's control is possible with RS-485, DRY contact or WLAN.



Split heat pump's water unit can be fully integrated inside the jacuzzi. It is thus fully invisible and also protected against frost.

9.2 kW
45 m³

HP 1000 GREEN

12.3 kW
55 m³

HP 1400 GREEN



Cover	COP	Heating output	Cooling output	COP	Heating output	Cooling output
ABS plastic	6.1 (A27 W27)*	9.2 kW (A27 W27)*	4.9 kW (A35 W28)*	6.0 (A27 W27)*	12.3 kW (A27 W27)*	6.2 kW (A35 W28)*

SEASON 0~43°C **FULL YEAR** -15~43°C

HP 1000 GREEN Compact - 1. - 2. - 3.
HP 1400 GREEN Compact - 1. - 2. - 3.



EXCHANGER EQUIPPED with 0.42 m² of TITANIUM



HP 1000 GREEN

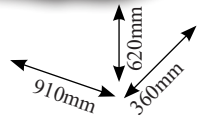

Basic equipment:	Model:	Price EXW w/o VAT /EUR/
Heat pump (including 4-way valve hot gas defrost and GoldFin), user's manual	HP 1000 GREEN Compact	1 210
anti VIBRATION + ultra QUIET + easy INSTALL +	HP 1400 GREEN Compact	1 430

1. Wi-Fi:	
S standard: without Wi-Fi	0
W with Wi-Fi	65
2. Full year modification:	
S standard: without WINTER module (0~43°C)	0
W WINTER module (-15~43°C)	570
3. Chiller adjustment:	
S standard: without	0
C CHILLER (extra thermal insulation) ... to allow water cooling to +8°C	140
Protection cover:	
Heavy duty waterproof UV resistant cover - tarpaulin made of truck cloth with long livelihood /Rebate does not apply on this item. This is the actual purchase price./	110



HP 1400 GREEN

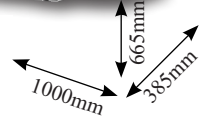

HP 1000 GREEN Split - 1. - 2. - 3.
HP 1400 GREEN Split - 1. - 2. - 3.



EXCHANGER EQUIPPED with 0.6 m² of TITANIUM

Basic equipment:	Model:	Price EXW w/o VAT /EUR/
Heat pump (including 4-way valve hot gas defrost and GoldFin), user's manual	HP 1000 GREEN Split	1 780
anti VIBRATION + ultra QUIET + easy INSTALL +	HP 1400 GREEN Split	2 030

1. Wi-Fi:	
S standard: without Wi-Fi	0
W with Wi-Fi	65
2. Full year modification:	
S standard: without WINTER module (0~43°C)	0
W WINTER module (-15~43°C)	570
3. Chiller adjustment:	
S standard: without	0
C CHILLER (extra thermal insulation) ... to allow water cooling to +8°C	140
Protection cover:	
Heavy duty waterproof UV resistant cover - tarpaulin made of truck cloth with long livelihood /Rebate does not apply on this item. This is the actual purchase price./	110



Wi-Fi module



Protection cover

EURO PALETTE packed, FUMIGATED
 17.50€/1pc (Depending on the model it is possible to pack more units on EUP (2-6pcs).)

REGULATION OVER Wi-Fi
 ANDROID and IOS APP available for free

16.2 kW
70 m³

HP 1700 GREEN

Cover	COP	Heating output	Heating output	Cooling output
ABS plastic	6.0 (A27 W27)*	11.3 kW (A15 W26RH70)	16.2 kW (A27 W27RH80)	8.3 kW (A35 W28RH80)



SEASON
0~43°C

FULL YEAR
-15~43°C

HP 1700 GREEN Compact - 1. - 2. - 3.



Basic equipment:

Heat pump (including 4-way valve hot gas defrost and GoldFin), user's manual

Price EXW
w/o VAT /EUR/

1 990

anti VIBRATION + ultra QUIET + easy INSTALL +

1. Wi-Fi:

S standard: without Wi-Fi	0
W with Wi-Fi	65

2. Full year modification:

S standard: without WINTER module (0~43°C)	0
W WINTER module (-15~43°C)	570

3. Chiller adjustment:

S standard: without	0
C CHILLER (extra thermal insulation) ... to allow water cooling to +8°C	140

Protection cover:

Heavy duty waterproof UV resistant cover - tarpaulin made of truck cloth with long livelihood <i>Rebate does not apply on this item. This is the actual purchase price./</i>	110
--	-----



Wi-Fi module



Protection cover

HP 1700 GREEN Split - 1. - 2. - 3.



Basic equipment:

Heat pump (including 4-way valve hot gas defrost and GoldFin), user's manual

Price EXW
w/o VAT /EUR/

2 520

anti VIBRATION + ultra QUIET + easy INSTALL +

1. Wi-Fi:

S standard: without Wi-Fi	0
W with Wi-Fi	65

2. Full year modification:

S standard: without WINTER module (0~43°C)	0
W WINTER module (-15~43°C)	570

3. Chiller adjustment:

S standard: without	0
C CHILLER (extra thermal insulation) ... to allow water cooling to +8°C	140

Protection cover:

Heavy duty waterproof UV resistant cover - tarpaulin made of truck cloth with long livelihood <i>/Rebate does not apply on this item. This is the actual purchase price./</i>	110
---	-----

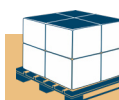

EURO PALETTE packed, FUMIGATED
17.50€/1pc (Depending on the model it is possible to pack more units on EUP (2-6pcs).)



v. 01/2023

MICROWELL

39

23 kW 80 m ³				28.4 kW 120 m ³		
HP 2300 INVENTOR Compact				HP 2800 INVENTOR Compact		
Cover	COP	Heating output	Cooling output	COP	Heating output	Cooling output
metal	5.8 - 7.6 (A26 W26)*	20.9-27.2 kW (A26 W26)*	20.1 kW (A30 W35)*	5.8 - 7.6 (A26 W26)*	25.8-33.5 kW (A26 W26)*	25 kW (A30 W35)*

SEASON -5~40°C	FULL YEAR -15~40°C	TROPICAL -5~60°C
--------------------------	------------------------------	----------------------------



HP 2300 INVENTOR C - 1. - 2. - 3. - 4.



EXCHANGER EQUIPPED with 0.95 m² of TITANIUM

HP 2800 INVENTOR C - 1. - 2. - 3. - 4.



EXCHANGER EQUIPPED with 1.2 m² of TITANIUM



Basic equipment:	Model:	Price EXW w/o VAT /EUR/
Heat pump (including GoldFin, Panasonic/Sanyo compressor, 4-way valve hot gas defrost, EEV), user's manual	HP 2300 INVENTOR C	4 250
micro COMPRESSOR + micro ECONOMY + anti VIBRATION + anti FREEZE + ultra QUIET +	HP 2800 INVENTOR C	4 610

1. Full year modification:		
S standard: without WINTER module (-5°C...+40°C)		0
W with WINTER module (-15°C...+40°C)		350
2. Tropical / Chiller adjustment:		
S standard: without		0
T TROPICAL KIT (extra compressor cooling) ... up to 60°C ambient air		270
C CHILLER (extra thermal insulation) ... to allow water cooling to +5°C		215
3. Control display placement:		
S standard: control display placed on the heat pump		0
W wall installation (out of the heat pump), includes wall plaster box, 30m cable		40
4. Wi-Fi:		
S standard: without Wi-Fi		0
W with Wi-Fi		49
Protection cover:		
Heavy duty waterproof UV resistant cover - tarpaulin made of truck cloth with long livelihood /Rebate does not apply on this item. This is the actual purchase price./		230
Self-regulating heating cable:		
230V/4m/64W, Euro plug 2m, IP68 /Rebate does not apply on this item. This is the actual purchase price./		28.50



ALLOWING HEAT PUMP USAGE IN AMBIENT AIR FROM +42°C TO +60°C.



EXCHANGER EQUIPPED WITH TITANIUM

EURO PALLETTE packed, FUMIGATED
17.50€/1pc (Depending on the model it is possible to pack more units on EUP (2-6pcs).)

REGULATION OVER Wi-Fi
ANDROID and IOS APP available for free

Pool Vision



23 kW
80 m³

HP 2300 INVENTOR Split

Cover	COP	Heating output	Cooling output
metal	5.8 - 7.6 (A26 W26)*	20.9-27.2 kW (A26 W26)*	20.1 kW (A30 W35)*

28.4kW
120 m³

HP 2800 INVENTOR Split

COP	Heating output	Cooling output
5.8 - 7.6 (A26 W26)*	25.8-33.5 kW (A26 W26)*	25 kW (A30 W35)*

SEASON
-5~40°C

FULL YEAR
-15~40°C

TROPICAL
-5~60°C

HP 2300 INVENTOR S - 1. - 2. - 3. - 4.



EXCHANGER
EQUIPPED with
0.95
m²
of TITANIUM

HP 2800 INVENTOR S - 1. - 2. - 3. - 4.



EXCHANGER
EQUIPPED with
1.2
m²
of TITANIUM



SWIMMING POOL HEAT PUMPS - ON-OFF

Basic equipment:

Air unit (including GoldFin, Panasonic/Sanyo compressor, 4-way valve hot gas defrost, EEV), Hydro kit - water titanium exchanger (installation in technical room), user's manual

Model:

HP 2300
INVENTOR S

Price EXW
w/o VAT /EUR/

4 350

micro COMPRESSOR + micro ECONOMY +

anti VIBRATION + anti FREEZE + ultra QUIET +

HP 2800
INVENTOR S

4 690

1. Control display placement:

S standard: digital display placed on outside unit (air unit) 0

W wall installation (out of the heat pump), includes wall plaster box, 30m cable 30

2. Wi-Fi:

S standard: without Wi-Fi 0

W with Wi-Fi 49

3. Full year modification:

S standard: without WINTER module (-5°C...+40°C) 0

W with WINTER module (-15°C...+40°C) 350

4. Tropical / Chiller adjustment:

S standard: without 0

T TROPICAL KIT (extra compressor cooling) ... up to 60°C ambient air 270

C CHILLER (extra thermal insulation) ... to allow water cooling to +5°C 215

Protection cover:

Heavy duty waterproof UV resistant cover - tarpaulin made of truck cloth with long livelihood *Rebate does not apply on this item. This is the actual purchase price./* 230



Hydro kit

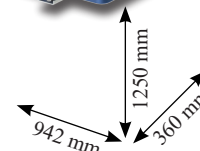

S



W



Wi-Fi modul



Protection cover



ALLOWING HEAT PUMP USAGE
IN AMBIENT AIR FROM +42°C
TO +60°C.



EXCHANGER EQUIPPED WITH
TITANIUM

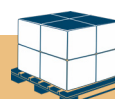

EURO PALLETTE packed, FUMIGATED

17.50€/1pc

(Depending on the model it is possible to pack more units on EUP (2-6pcs).)



v. 01/2023

MICROWELL

Solves 3 cases out of 5 remotely

IOT SERVICE CONSOLE

- 24/7 online supervision system
- Real-time & historical data
- Fault advice & solution
- Remote control & parameter settings
- Complete technical analysis remotely
- Up to 90 days data storage

**SAVES MINIMUM
1 SERVICE VISIT**





**PROTECTED
DATA**

**WIFI
CONTROL**

**ONLINE
DIAGNOSTICS**

**24/7
SUPERVISION**

9kW 30 m ³	HP 900 BLACK Inverter				11.5kW 35 m ³	HP 1100 BLACK Inverter		
	Cover	COP	Heating output	Cooling output		COP	Heating output	Cooling output
	ABS plastic, black	10.6 - 5.8 (A26 W26)*	1.8 - 9.0 kW (A26 W26)*	2.7 kW (A43 W35)*		10.9 - 5.9 (A26 W26)*	2.3 - 11.5 kW (A26 W26)*	3.5 kW (A43 W35)*



HP 900/1100 BLACK

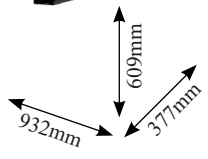

HP 900 BLACK Inverter Compact - 1.



HP 1100 BLACK Inverter Compact - 1.

Basic equipment:	Model:	Price EXW w/o VAT /EUR/
Heat pump (including full stepless inverter DC compressor, brushless DC ventilator, GoldFin/, 4-way valve hot gas defrost), protection cover, user's manual, WIFI, IOT service console anti VIBRATION + ultra QUIET + easy INSTALL +	HP 900 BLACK Compact	1 350
	HP 1100 BLACK Compact	1 460

1. Control display placement:	
S standard: control display placed on the heat pump	0
R remote regulation, 10m cable, touch controller	170



HP 900 BLACK Inverter Split - 1.



HP 1100 BLACK Inverter Split - 1.

Basic equipment:	Model:	Price EXW w/o VAT /EUR/
Heat pump (including full stepless inverter DC compressor, brushless DC ventilator, GoldFin/, 4-way valve hot gas defrost), protection cover, user's manual, WIFI, IOT service console anti VIBRATION + ultra QUIET + easy INSTALL +	HP 900 BLACK Split	1 700
	HP 1100 BLACK Split	1 920

1. Control display placement:	
S standard: control display placed on the heat pump	0
R remote regulation, 10m cable, touch controller	170



IOT APP CLOUD

EURO PALETTE packed, FUMIGATED
17.50€/1pc (Depending on the model it is possible to pack more units on EUP (2-6pcs).)

REGULATION OVER Wi-Fi
 ANDROID and IOS APP available for free

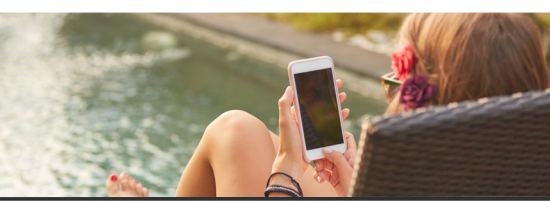

15 kW
50 m³

HP 1500 BLACK Inverter

Cover	COP	Heating output	Cooling output
ABS plastic, black	10.7 - 5.7 (A26 W26)*	2.9 - 15.4 kW (A26 W26)*	5.4 kW (A43W35)*

SEASON
-7~43°C

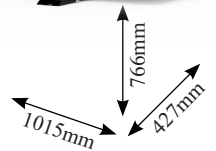

HP 1500 BLACK Inverter Compact - 1.



Basic equipment:	Model	Price EXW w/o VAT /EUR/
------------------	-------	----------------------------

Heat pump (including full stepless inverter DC compressor, brushless DC ventilator, GoldFin/, 4-way valve hot gas defrost), protection cover, user's manual, WIFI, IOT service console

HP 1500 BLACK Compact **1 780**

anti VIBRATION + ultra QUIET + easy INSTALL +

1. Control display placement

S standard: control display placed on the heat pump	0
R remote regulation, 10m cable, touch controller	170



HP 1500 BLACK Inverter Split - 1.



Basic equipment:	Model:	Price EXW w/o VAT /EUR/
------------------	--------	----------------------------

Heat pump (including full stepless inverter DC compressor, brushless DC ventilator, GoldFin/, 4-way valve hot gas defrost), protection cover, user's manual, WIFI, IOT service console

HP 1500 BLACK Split **2 250**

anti VIBRATION + ultra QUIET + easy INSTALL +

1. Control display placement

S standard: control display placed on the heat pump	0
R remote regulation, 10m cable, touch controller	170



IOT APP
CLOUD

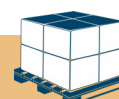

EURO PALETTE packed, FUMIGATED
17.50€/1pc (Depending on the model it is possible to pack more units on EUP (2-6pcs).)



v. 01/2023



10.8 kW
40 m³

HP 1100 GREEN Inverter Pro

Cover	COP	Heating output	Heating output	Cooling output
ABS plastic	14 - 6.4 (A26 W26)*	8.4 - 10.8 kW (A26 W26)*	12.4 kW (A27 W15RH80)	4.5 kW (A35 W28)*



FULL YEAR
-15~43°C

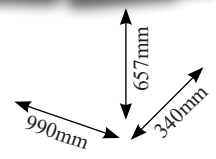

HP 1100 GREEN Inverter Pro Compact



Basic equipment:

Heat pump /full stepless inverter DC compressor, brushless DC ventilator, GoldFin/, including 4-way valve hot gas defrost and EEV, condensate tray defrost, WINTER module, WiFi, Touch control, user's manual

Price EXW
w/o VAT /EUR/

1 970

anti **VIBRATION** + ultra **QUIET** + easy **INSTALL** +

Protection cover:

Heavy duty waterproof UV resistant cover - tarpaulin made of truck cloth with long livelihood

70

/Rebate does not apply on this item. This is the actual purchase price./

HP 1100 GREEN Inverter Pro Split - 1.



Basic equipment:

Split heat pump - separate water unit with remote installation /full stepless inverter DC compressor, brushless DC ventilator, GoldFin/, including 4-way valve hot gas defrost and EEV, condensate tray defrost, WINTER module, WiFi, Touch control, user's manual

Price EXW
w/o VAT /EUR/

2 540

anti **VIBRATION** + ultra **QUIET** + easy **INSTALL** +

1. Control display placement:

S standard: control display placed on the heat pump

0

W wall installation (out of the heat pump), includes wall plaster box IP44, 10m cable, touch controller with Wi-Fi

150

Protection cover:

Heavy duty waterproof UV resistant cover - tarpaulin made of truck cloth with long livelihood

110

/Rebate does not apply on this item. This is the actual purchase price./



Protection cover



EURO PALETTE packed, FUMIGATED
17.50€/1pc (Depending on the model it is possible to pack more units on EUP (2-6pcs).)

★ **5 years WARRANTY**
ON COMPRESSOR ★

★ **5 years WARRANTY**
ON TITANIUM HEAT EXCHANGER ★

★ **2 years WARRANTY**
ON SPARE PARTS ★

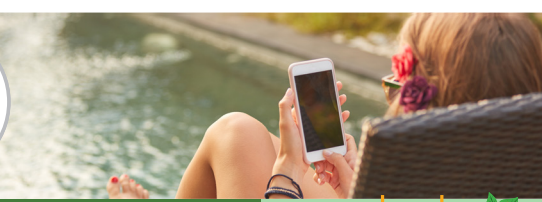

GREEN R32 LINE

15 kW
60 m³

HP 1500 GREEN Inverter Pro

Cover	COP	Heating output	Heating output	Cooling output
ABS plastic	15 - 6.5 (A26 W26)*	11.4 - 15 kW (A26 W26)*	17.3 kW (A27 W15RH80)	6.7 kW (A35 W28)*



FULL YEAR
-15~43°C



HP 1500 GREEN Inverter Pro Compact

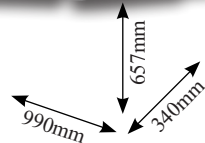

Basic equipment:

Heat pump /full stepless inverter DC compressor, brushless DC ventilator, GoldFin/, including 4-way valve hot gas defrost and EEV, condensate tray defrost, WINTER module, WiFi, Touch control, user's manual

Price EXW
w/o VAT /EUR/

2 490

anti **VIBRATION** + ultra **QUIET** + easy **INSTALL**+

Protection cover:

Heavy duty waterproof UV resistant cover - tarpaulin made of truck cloth with long livelihood

70

/Rebate does not apply on this item. This is the actual purchase price./

HP 1500 GREEN Inverter Pro Split - 1.



Basic equipment:

Split heat pump - separate water unit with remote installation /full stepless inverter DC compressor, brushless DC ventilator, GoldFin/, including 4-way valve hot gas defrost and EEV, condensate tray defrost, WINTER module, WiFi, Touch control, user's manual

Price EXW
w/o VAT /EUR/

3 230

anti **VIBRATION** + ultra **QUIET** + easy **INSTALL**+



1. Control display placement:

S standard: control display placed on the heat pump

0

W wall installation (out of the heat pump), includes wall plaster box IP44, 10m cable, touch controller with Wi-Fi

150

Protection cover:

Heavy duty waterproof UV resistant cover - tarpaulin made of truck cloth with long livelihood

110

/Rebate does not apply on this item. This is the actual purchase price./



W



Protection cover

★ **5 years WARRANTY**
ON COMPRESSOR ★

★ **5 years WARRANTY**
ON TITANIUM HEAT EXCHANGER ★

★ **2 years WARRANTY**
ON SPARE PARTS ★

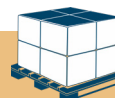

EURO PALETTE packed, FUMIGATED

17.50€/1pc

(Depending on the model it is possible to pack more units on EUP (2-6pcs).)



v. 01/2023



47

17 kW
95 m³

HP 1700 GREEN Inverter Pro

Cover	COP	Heating output	Heating output	Cooling output
ALUMINUM	15 - 6.5 (A26 W26)*	11.5 - 17.0 kW (A26 W26)*	19.6 kW (A27 W15RH8o)	7.5 kW (A35 W28)*



FULL YEAR
-15~43°C



EXCHANGER
EQUIPPED with
0.8m²
of TITANIUM



HP 1700 GREEN Inverter Pro Compact

Basic equipment:

Heat pump /full stepless inverter DC compressor, brushless DC ventilator, GoldFin/, including 4-way valve hot gas defrost and EEV, condensate tray defrost, WINTER module, WiFi, Touch control, user's manual

Price EXW
w/o VAT /EUR/

2 930

anti **VIBRATION** + ultra **QUIET** + easy **INSTALL** +

Protection cover:

Heavy duty waterproof UV resistant cover - tarpaulin made of truck cloth with long livelihood
/Rebate does not apply on this item. This is the actual purchase price./

110

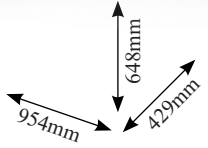

HP 1700 GREEN Inverter Pro Split - 1.



Basic equipment:

Split heat pump - separate water unit with remote installation /full stepless inverter DC compressor, brushless DC ventilator, GoldFin/, including 4-way valve hot gas defrost and EEV, condensate tray defrost, WINTER module, WiFi, Touch control, user's manual

Price EXW
w/o VAT /EUR/

3 590

anti **VIBRATION** + ultra **QUIET** + easy **INSTALL** +

1. Control display placement:

S standard: control display placed on the heat pump

0

W wall installation (out of the heat pump), includes wall plaster box IP44, 10m cable, touch controller with Wi-Fi

150

Protection cover:

Heavy duty waterproof UV resistant cover - tarpaulin made of truck cloth with long livelihood
/Rebate does not apply on this item. This is the actual purchase price./

150



Protection cover

EURO PALETTE packed, FUMIGATED
17.50€/1pc (Depending on the model it is possible to pack more units on EUP (2-6pcs).)

★ **5 years WARRANTY**
ON COMPRESSOR ★

★ **5 years WARRANTY**
ON TITANIUM HEAT EXCHANGER ★

★ **2 years WARRANTY**
ON SPARE PARTS ★

REGULATION OVER Wi-Fi
ANDROID and IOS APP available for free



GREEN R32 LINE

24.2 kW
105 m³

HP 2100 GREEN Inverter Pro

Cover	COP	Heating output	Heating output	Cooling output
ALUMINUM	14.8~6.4 (A26 W26)*	14.5~21kW (A26 W26)*	24.2 kW (A27 W15RH8o)	9.5 kW (A35 W28)*



FULL YEAR
-15~43°C

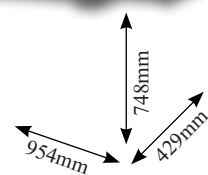

HP 2100 GREEN Inverter Pro Compact



Basic equipment:

Heat pump /full stepless inverter DC compressor, brushless DC ventilator, GoldFin/, including 4-way valve hot gas defrost and EEV, condensate tray defrost, WINTER module, WiFi, Touch control, user's manual

Price EXW
w/o VAT /EUR/

3 420

anti **VIBRATION** + ultra **QUIET** + easy **INSTALL** +

Protection cover:

Heavy duty waterproof UV resistant cover - tarpaulin made of truck cloth with long livelihood

110

/Rebate does not apply on this item. This is the actual purchase price./

HP 2100 GREEN Inverter Pro Split - 1.



Basic equipment:

Split heat pump - separate water unit with remote installation /full stepless inverter DC compressor, brushless DC ventilator, GoldFin/, including 4-way valve hot gas defrost and EEV, condensate tray defrost, WINTER module, WiFi, Touch control, user's manual

Price EXW
w/o VAT /EUR/

4 220

anti **VIBRATION** + ultra **QUIET** + easy **INSTALL** +

1. Control display placement:

S standard: control display placed on the heat pump

0

W wall installation (out of the heat pump), includes wall plaster box IP44, 10m cable, touch controller with Wi-Fi

150

Protection cover:

Heavy duty waterproof UV resistant cover - tarpaulin made of truck cloth with long livelihood

150

/Rebate does not apply on this item. This is the actual purchase price./



W



Protection cover

★ **5 years WARRANTY**
ON COMPRESSOR ★

★ **5 years WARRANTY**
ON TITANIUM HEAT EXCHANGER ★

★ **2 years WARRANTY**
ON SPARE PARTS ★

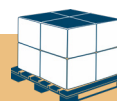

EURO PALETTE packed, FUMIGATED

17.50€/1pc

(Depending on the model it is possible to pack more units on EUP (2-6pcs).)

GREEN R32 LINE



v. 01/2023



31.6 kW
135 m³

HP 2700 GREEN Inverter Pro

Cover	COP	Heating output	Heating output	Cooling output
ALUMINUM	15~6.5 (A26 W26)*	18 - 27.5 kW (A26 W26)*	31.6 kW (A27 W15RH80)	11.9 kW (A35 W28)*



FULL YEAR
-15~43°C

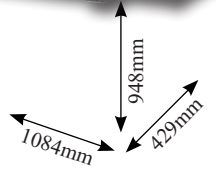

HP 2700 GREEN Inverter Pro Compact



Basic equipment:

Price EXW
w/o VAT /EUR/

Heat pump /full stepless inverter DC compressor, brushless DC ventilator, GoldFin/, including 4-way valve hot gas defrost and EEV, condensate tray defrost, WINTER module, WiFi, Touch control, user's manual

4 260

anti VIBRATION + ultra QUIET + easy INSTALL +

Protection cover:

Heavy duty waterproof UV resistant cover - tarpaulin made of truck cloth with long livelihood

120

/Rebate does not apply on this item. This is the actual purchase price./

HP 2700 GREEN Inverter Pro Split - 1.



Basic equipment:

Price EXW
w/o VAT /EUR/

Split heat pump - separate water unit with remote installation /full stepless inverter DC compressor, brushless DC ventilator, GoldFin/, including 4-way valve hot gas defrost and EEV, condensate tray defrost, WINTER module, WiFi, Touch control, user's manual

5 240

anti VIBRATION + ultra QUIET + easy INSTALL +

1. Control display placement:

S standard: control display placed on the heat pump

0

W wall installation (out of the heat pump), includes wall plaster box IP44, 10m cable, touch controller with Wi-Fi

150

Protection cover:

Heavy duty waterproof UV resistant cover - tarpaulin made of truck cloth with long livelihood

170

/Rebate does not apply on this item. This is the actual purchase price./



Protection cover

EURO PALETTE packed, FUMIGATED
17.50€/1pc (Depending on the model it is possible to pack more units on EUP (2-6pcs).)

★ **5 years WARRANTY**
ON COMPRESSOR ★

★ **5 years WARRANTY**
ON TITANIUM HEAT EXCHANGER ★

★ **2 years WARRANTY**
ON SPARE PARTS ★



COMPACT versus SPLIT



WATER EXCHANGER



TECHNICAL POOL ROOM

- Comfortable full year heating
- Winterizing is not necessary
- No noise, no vibration, no visual distraction



” Split heat pump does not require winterizing because its water exchanger is placed in a place where it does not freeze, such as e.g. technical pool room, cellar or land. ”

24.4 kW 80 m ³	HP 2400 PREMIUM Compact			30.1kW 120 m ³	HP 3000 PREMIUM Compact		
	Cover	COP	Heating output		Cooling output	COP	Heating output
	metal	6.5 - 8.5 (A26 W26)*	22.2-28.8 kW (A26 W26)*	21.7 kW (A30 W35)*	6.5 - 8.5 (A26 W26)*	27.4-35.5 kW (A26 W26)*	26.8 kW (A35 W28)*

FULL YEAR -15~40°C **TROPICAL** -5~60°C



HP 2400 PREMIUM C



EXCHANGER EQUIPPED with **1.2m²** of TITANIUM

HP 3000 PREMIUM C



EXCHANGER EQUIPPED with **1.4m²** of TITANIUM

Basic equipment:	Model:	Price EXW w/o VAT /EUR/
<ul style="list-style-type: none"> Heat pump (including GoldFin), Full year operation down to -15°C (including complete Winter package: condensate tray defrost, heat exchanger frost protection, winter module), Tropical kit allowing operations up to +60°C ambient air, Water cooling down to +5°C (chiller), Wi-Fi by standard TUYA IOT based App for iOS/Android Smart "POOL VISION", Remote wall controller including 30m cable, Thermally insulated water exchanger, User's manual 	HP 2400 PREMIUM Compact	4 890
	HP 3000 PREMIUM Compact	5 260
<p>micro COMPRESSOR+ micro ECONOMY+ anti VIBRATION+ anti FREEZE+ ultra QUIET+</p>		
Protection cover:		
Heavy duty waterproof UV resistant cover - tarpaulin made of truck cloth with long livelihood /Rebate does not apply on this item. This is the actual purchase price./		230
Self-regulating heating cable:		
230V/4m/64W, Euro plug 2m, IP68 /Rebate does not apply on this item. This is the actual purchase price./		28.50



1550 mm
942 mm
360 mm



Protection cover



Cable

EURO PALETTE packed, FUMIGATED
17.50€/1pc (Depending on the model it is possible to pack more units on EUP (2-6pcs).)



24.4 kW
80 m³

HP 2400 PREMIUM Split

Cover	COP	Heating output	Cooling output
metal	6.5 - 8.5 (A26 W26)*	22.2 - 28.8 kW (A26 W26)*	21.7 kW (A30 W35)*

30.1 kW
120 m³

HP 3000 PREMIUM Split

COP	Heating output	Cooling output
6.5 - 8.5 (A26 W26)*	27.4 - 35.5 kW (A26 W26)*	26.8 kW (A35 W28)*

FULL YEAR
-15~40°C

TROPICAL
-5~60°C



HP 2400 PREMIUM S



EXCHANGER
EQUIPPED with
1.2m²
of TITANIUM

HP 3000 PREMIUM S



EXCHANGER
EQUIPPED with
1.4m²
of TITANIUM



Protection cover

Basic equipment:

- Air unit (including GoldFin) + Hydro kit (without box)
- Full year operation down to -15°C, (including complete Winter package: condensate tray defrost, winter module),
- Tropical kit allowing operations up to +60°C ambient air,
- Water cooling down to +5°C (chiller),
- Wi-Fi by standard TUYA IOT based App for iOS/Android Smart "POOL VISION",
- Remote wall controller including 30m cable,
- Thermally insulated water exchanger,
- User's manual

micro COMPRESSOR +

micro ECONOMY +

anti VIBRATION +

anti FREEZE +

ultra QUIET +

Protection cover:

Heavy duty waterproof UV resistant cover - tarpaulin made of truck cloth with long livelihood
/Rebate does not apply on this item. This is the actual purchase price./

230

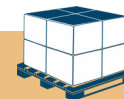

EURO PALETTE packed, FUMIGATED

17.50€/1pc

(Depending on the model it is possible to pack more units on EUP (2-6pcs).)

TROPICAL
ALLOWING HEAT PUMP USAGE
IN AMBIENT AIR FROM +42°C
TO +60°C.



v. 01/2023

MICROWELL

60kW 260 m ³ iMax 60				115kW 520 m ³ iMax 110		
Cover	COP	Heating output	Cooling output	COP	Heating output	Cooling output
ABS plastic	10.5 (A27 W27)*	60.2 kW (A27 W27)*	26.8 kW (A35 W28)*	10.0 (A27 W27)*	115.0 kW (A27 W27)*	53.5 kW (A35 W28)*



iMax 60 HC



iMax 110 HC

Basic equipment:	Model:	Price EXW /* w/o VAT /EUR/
Heat pump, user's manual		
Operating air temperature: -10°C ~ +43°C	60 kW iMax 60	7 500
	115 kW iMax 110	12 600



iMax 60

iMax 60 Tropical HC



iMax 110 Tropical HC

Basic equipment:	Model:	Price EXW /* w/o VAT /EUR/
Heat pump, user's manual		
Operating air temperature: 0°C ~ +55°C	60 kW iMax 60	8 600
	115 kW iMax 110	15 500

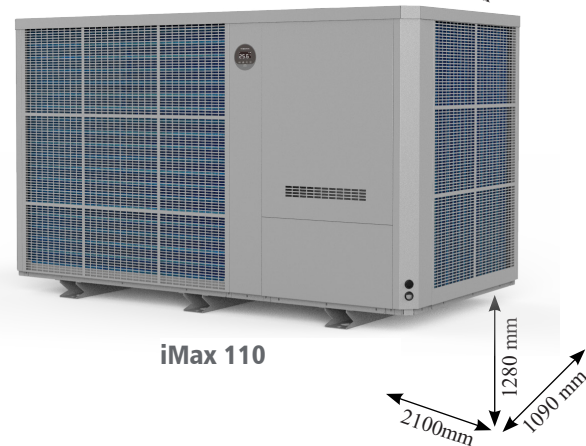

iMax 110

/* Final prices. General discount does not apply on these items.



EURO PALETTE packed, FUMIGATED
17.50€/1pc (Depending on the model it is possible to pack more units on EUP (2-6pcs).)

Designed for public /commercial applications such as public pools, hotel pools, school pools.

125m³ – 520m³ Pool Available

MULTIPLE Heat pump

up to 800m³



- Apply multiple Microwell heat pump units
- Up to **10pcs** in parallel connection
- Up to **350kW** power
- Save on transport & handling costs
- Make the maintenance & service easier and cheaper
- Use Smart step regulation
- ModBus available



ACCESSORIES & Spare parts

Measurement and regulation
Installation material and equipment
Spare parts
Water surface covering
Ventilation

**The widest selection of finishes
and accessories.**

Benefits that customers desire

Based on close relationship with
customers, Microwell provides
functionality through matchless
selection of accessory options.

Qmax - Heat pump TESTER

Save up to
30%
on energy
bill



FOR SETTING THE QUALITY
of pool performance

www.microwell.eu

ACCESSORIES & Spare parts

Carry-on measurement device designed to provide measurement and optimization of heat pump's performance and efficiency

Price EXW
w/o VAT /EUR/

Basic equipment:

- Carry on measurement device with inductive flow meter KROHNE Optiflux 2050 with connection DN50
- A pair of mobile WIKA Pt100 resistance thermometers
- Measurement device

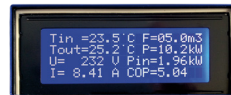

1. Qmax-TESTER

measures: water temperature inlet & outlet, true heating or cooling output, heat pump power consumption, water flow
counts: Coefficient of performance /COP/, Energy efficiency ratio /EER/

2 890

2. Heat pump's OPTIMIZATION

executed by a Microwell trained technician

99



IMMEDIATE TESTING
OF A HEAT PUMP



COMPATIBLE
WITH ALL 1 PHASE HP

WATCH VIDEO & LEARN MORE



/General discount does not apply on above stated prices. Stated prices are final./



1. FLOAT SWITCHES FOR EQUALIZING TANKS

Float switches for equalizing tanks	Price EXW w/o VAT /EUR/
1.1. NIVOCONT - conductive level switch	
1.1.A KSN-201 - probe from stainless steel	33.60
1.1.B KRK-512-5 - relay	47.30
1.2. NIVOFLOAT - plastic level switch	
1.2.A NLP-110 - plastic level float switch (PVC cable 10m)	31.80
1.3. NIVOPOINT - multiple switching point magnetic level switch:	
1.3.A MRA-210-3 - multiple switching point level switch with wetted parts from stainless steel (1" thread, 2 switching points, probe tube 1m)	204.00

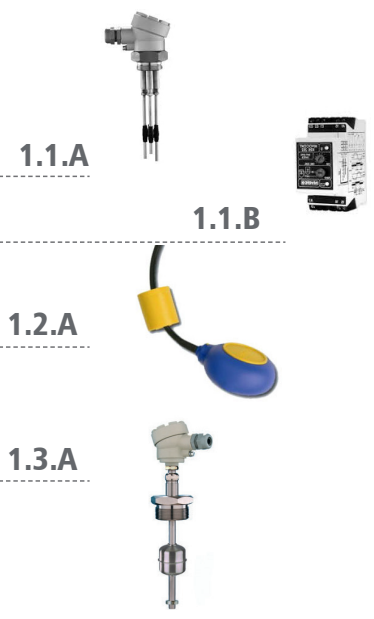

2. HUMIDITY AND TEMPERATURE METER in 1

Device for indoor humidity and temperature measuring	Price EXW w/o VAT /EUR/
2.1. Thermo-humidistat BEURER HM 16	
Humidity 20% to 95% Air temperature 0°C ~ +50°C Selection °C/°F Wall installation / flipping holder Well readable display Measurement accuracy ± 5% Battery 1x 1.5V	14.40
2.2. PROFESSIONAL- GFTH 95 (professional application)	
Humidity measurement accuracy: ± 1,5% 1 line LCD Battery included 1x 9V, typ IEC 6F22 Body: ABS	153.00

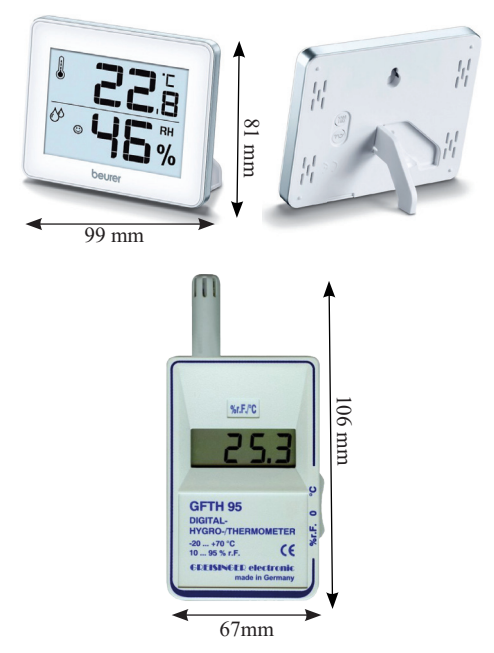

/Change in price and offered products reserved./

3. HUMIDITY VISUALIZATION

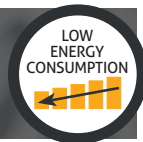

microLIGHT+

Price EXW
w/o VAT /EUR/

3.1. microLIGHT+ INFINITY

Operational temperature range: 0°C ... +60°C.
Compatibility: All DRY range

3.1.A microLIGHT+ INFINITY, length 1 m	183.00
3.1.B microLIGHT+ INFINITY, length 3 m	213.00
3.1.C microLIGHT+ INFINITY, length 5 m	228.00

3.2. microLIGHT+ LAMP

A freestanding table lamp.
MicroLIGHT+ LAMP measures and automatically reflects current relative humidity, changing the colour gradient between blue, green and red colour.

3.2.A microLIGHT+ LAMP	105.00
------------------------	--------

/Change in Lamp model reserved./

3.3. microSTEAM+

Operational temperature range: 0°C ... +120°C.
Designed for ceilings of the swimming pool halls as LED humidistat for saunas.

3.3.A microSTEAM+, length 1 m	229.00
3.3.B microSTEAM+, length 2 m	253.00

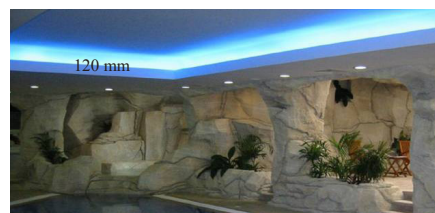
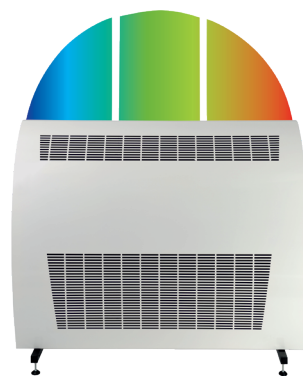

ACCESSORIES & Spare parts

Low humidity 0-40% RH

Ideal humidity 40-60% RH

High humidity 60-100% RH

microLIGHT+

Integrated LED light strip indicating current humidity in a pool. Light spectrum from blue (humidity low) through green (all OK) to red (problem – humidity high) in full color gradient.

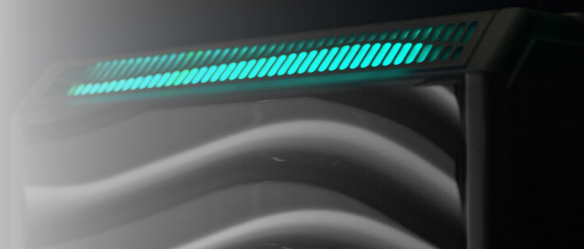

v. 01/2023

MICROWELL

59

4. FLOOR GRILLS

Price change reserved

/Actual price to be quoted based on an individual enquiry./

Price EXW
w/o VAT /EUR/

4.1. Basic structure

4.1.A	Symmetrical ASS	from 154.00
4.1.B	Asymmetrical ASU	from 160.00
4.1.C	Asymmetrical removable ASR	from 207.00
4.1.D	LED Asymmetrical removable ASR	from 352.00

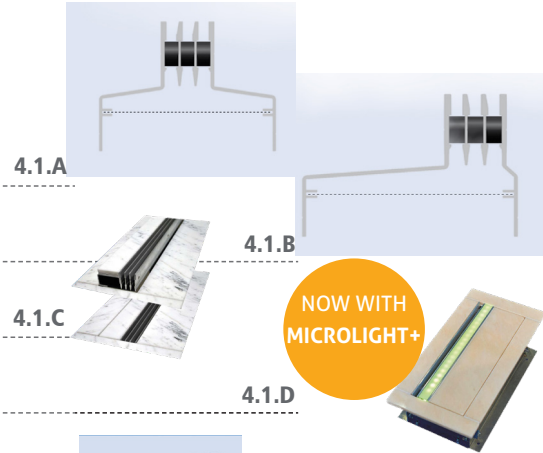

4.2. Fixation

4.2.A	Mounting rail AS-BF	from 34.50
4.2.B	Substructure channel AS-UBK	from 252.00

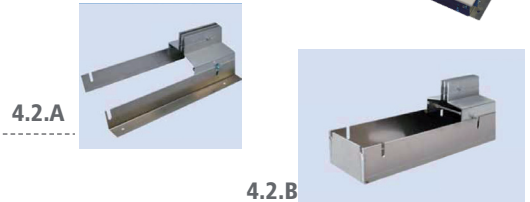

4.3. Accessories

4.3.A	Comer AS-GS	from 69.90
4.3.B	Diffuser AS-DLV	from 11.40
4.3.C	Construction works protection cover AS-AP	from 6.50
4.3.D	Cut out for substructure channel AS-UBK-A	from 13.00
4.3.E	Substructure channel socket AS-UBK-ZSR	from 28.40
4.3.F	Side cut out with socket for mounting rail or substructure channel AS-UBK-ZS	from 28.40
4.3.G	End cover AS-END	from 16.80
4.3.H	Condensate drain for substructure channel AS-UBK-AS	from 47.00

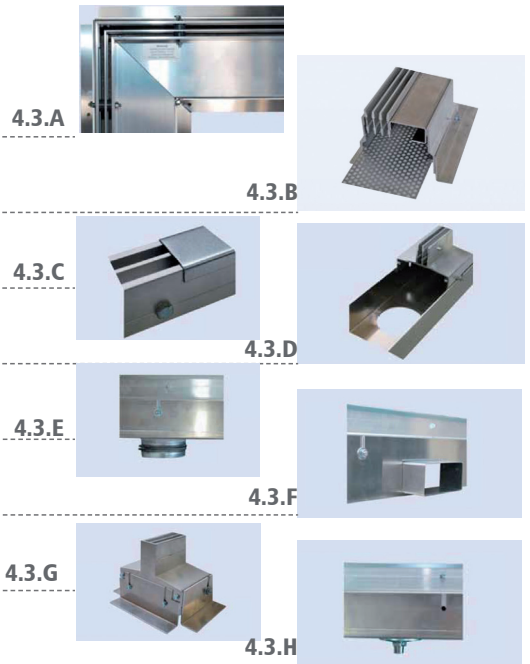

/Price change reserved./



5. INSTALLATION MATERIAL

5.1 for SWIMMING POOL DEHUMIDIFIERS installation		unit	Price EXW w/o VAT /EUR/
5.1.1. Pumps and accessories			
5.1.1.A	Pump SI 83 – condensing, with tank 2l, 500l/h, max. 4.2m /No. 7012/	1 pc	75.00
5.1.1.B	Condensate hose 16mm internal / 20mm external flexible /No. 7100/	1 standard meter	0.95
5.1.2. Cleaning and disinfection appliances			
5.1.2.A	Easy Care spray – evaporator cleaner and disinfection /No. 5008/	1 pc	14.10
5.1.3. In-wall condensate siphons			
5.1.3.A	In-wall condensate siphon, DN32/20 /No. 7103/	1 pc	32.00
5.1.4. Anti odor siphons			
5.1.4.A	Siphon (anti-odor trap) for condensation hose /No. 7102/	1 pc	7.00



5.1.1.A



5.1.1.B



5.1.2.A



5.1.3.A



5.1.4.A

5.2 for SWIMMING POOL HEAT PUMP installation		unit	Price EXW w/o VAT /EUR/
5.2.1. Copper pipes			
5.2.1.A	for HP900/1100 BLACK SPLIT, HP1100 GREEN INVERTER Pro SPLIT Insulated double copper pipes DUO 6+12 (1/4" + 1/2" x 0.8) - 25m package /No. 2011/	1m	6.50
5.2.1.B	for HP1400/1700 GREEN (On-Off), HP1500/1700/2100 GREEN Inverter Pro SPLIT, HP 1500 BLACK Insulated double copper pipes DUO 10+16 (3/8" x 5/8") - 25m package /No. 2012/	1m	10.00
5.2.1.C	for HP2300/2800 INVENTOR, HP2400/3000 PREMIUM, HP2700 GREEN INVERTER Pro SPLIT Insulated copper pipes d10 (3/8" x 1.0)- 50m package /No. 2003/ + insulated copper pipes d18 (3/4" x 1.0")- 25m package /No. 2007/	1m	13.00
5.2.1.D	for DRY SIREN, HP 1000 GREEN (On-Off) Insulated copper pipes d12 (1/2" x 1.0)- 50m package /No. 2005/ + insulated copper pipes d10 (3/8" x 1.0)- 50m package /No. 2003/	1m	10.50



5.2.2. Insulation tape			
5.2.2.A	A self-adhesive insulation tape K-flex white /No. 2016/	1 pc	13.40
5.2.3. Consoles and base blocks			
5.2.3.A	Console White - 700 /No. 6004/, 2 pcs	set	44.00
5.2.3.B	Base installation block 450 – white, carrying capacity 200kg, 2pcs /No. 6055/, with Side covers, 4 pcs /No. 6061/	set	8.60
5.2.3.C	Rubber base installation block 400mm - black, carrying capacity 200kg. Set includes 2pcs. Price is stated for 1pc /No. 6065/ Compatibility: HP1000-1400 GREEN, HP1100-1500 GREEN INVERTER Pro, HP 900/1100 BLACK	set	26.40
5.2.3.D	Rubber base installation block 600mm - black, carrying capacity 200kg. Set includes 2pcs. Price is stated for 1pc /No. 6066/ Compatibility: HP1700-2100-2700 GREEN INVERTER Pro, HP2300-3000 INVENTOR & PREMIUM, HP 1500 BLACK	set	34.80
5.2.3.E	Antivibration silentblocks, 4pcs /No. 6023/	set	16.80



5.2.2.A



5.2.3.A



5.2.3.B

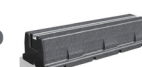

5.2.3.C|D

5.2.3.E



/Price change reserved./

General discount does not apply on above stated prices. Stated prices are final.



v. 01/2023

MICROWELL

6. EQUIPMENT FOR INSTALLATION AND SERVICE

Price change reserved



Price EXW
w/o VAT /EUR/

6.1. Vacuum pump

6.1.A Vacuum pump Rothenberger ROAIRVAC 6,0 - 170l/min **325**

6.1.B Refco - ENVIRO DUO OS, recovery station with oil separation - 4687035, gas 33kg/h, liquid 210 kg/h, Push pull 570kg/h **1 140**

6.1.A



6.1.B



6.2. Charging and testing hoses Refco

6.2.A Premium with closure valve, length 90cm **50**

6.2.B Premium with closure valve, length 150cm **60**

6.2.A|B



6.3. Manifold valve Refco

6.3.A for refrigerant R410, R32 **95**

6.3.B for refrigerant R22, R407, R410 **85**

6.3.A



6.3.B



6.4. Eccentric flare tool

6.4.A Eccentric flare tool Rothenberger, with 1" flare matrix, 222402 **150**

6.4.B Eccentric flare tool REFCO, with 1" flare matrix in small suitcase, RF888Z **120**

6.4.C Eccentric flare tool REFCO, flare matrix and cutter in small suitcase, RF275FS **90**

6.4.D Flare tool Rothenberger with expanding - 1" packet **55**

6.4.A



6.4.B



6.4.C



6.4.D



6.5. Expanders

6.5.A Expander Rothenberger 3/8, 1/2, 5/8, 3/4, 22, 28 - 1" packet, 12320 **340**

6.5.A



6.6. Cutters

6.6.A Cutter Rothenberger MINIMAX 3 - 28mm, 70015 **25**

6.6.B Cutter Rothenberger TC 35, 6- 35mm, 70027 **30**

6.6.A



6.6.B



6.7. Tube benders

6.7.A Tube bender Rothenberger TBM 3/8, 1/2, 5/8, 3/4, 7/8, 23022X **225**

6.7.A



6.8. Charging scales

6.8.A Charging scale Rothenberger to 120kg - accuracy 2g, 173004 **275**

6.8.B Charging scales TST **170**

6.8.A



6.8.B



/Price and model change reserved./

7. WATER CONNECTION PACKET

Price change reserved



for HEAT PUMP CONNECTION to pool water circuit

	/Price for the whole set/	Price EXW w/o VAT /EUR/
7.1.	WATER CONNECTION PACKET for HP Premium, Inventor	120.00
7.2.	WATER CONNECTION PACKET for HP Green, Green Inverter Pro	110.00



1 Pressure hose d50, length 10m /No. 211055/

2 PVC tube d50, length 0.8m /No. 211061/

3 Tube holder, open, d50, 8pcs /No. 211050/

4 Hose nut / Swivel for glue d50 x external thread 1 1/2", 2pcs /No. 211049/

5 PVC tube knee 90° for glue, 8pcs /No. 211046/

6 Swivel with valve for glue d50, 3pcs /No. 211048/

7 PVC "T" piece 90° for glue d50, 2pcs /No. 211047/

8 Glue Tangit PVC-U, 250g /No. 211051/

9 Cleaner Tangit 125 ml /No. 211052/

10 Sealing fibre Tangit Uni-Lock, 1 package /No. 211054/

11 Teflon tape 12 mm/12 m /No. 211053/

12 Screw fasteners with screws, 8pcs, dimensions: 10x48mm /No. 206013/

13 Screw fasteners with screws, 8pcs, dimensions: 6x70mm /No. 206023/

14 Cardboard box, 800x600x600 mm /No. 210005/

/Price change reserved./

General discount does not apply on above stated prices.
Stated prices are final.



SMART PURCHASE
Buy the whole set.



/Picture is illustratory./

ACCESSORIES & Spare parts



v. 01/2023

MICROWELL

8. SPARE PARTS

8.A.

DEHUMIDIFIER SPARE PARTS

Price EXW
w/o VAT /EUR/

Compressors and capacitors

103001	Compressor DRY 300: including siphon, silentblocks, heat protection, cover, Daikin OEM	305
112003	Compressor DRY 300: including siphon, silentblocks, heat protection, cover, LG	485
103008	Compressor DRY 500: including siphon, silentblocks, heat protection, cover, Daikin OEM	415
112004	Compressor DRY 500: including siphon, silentblocks, heat protection, cover, LG	575
103015	Compressor DRY 800: including siphon, silentblocks, heat protection, cover	840
103016	Compressor DRY 1200: including siphon, silentblocks, heat protection, cover	1 065
103005	Compressor capacitor DRY 300: 30µF 400/450V	8
103324	Compressor capacitor DRY 400: 40µF 400/450V	8
103011	Compressor capacitor DRY 500: 35µF 400/450V	8
103017	Compressor capacitor DRY 800: 45µF 400/450V	10
103018	Compressor capacitor DRY 1200: 50µF 400/450V	10

Fans

103002	Fan for DRY 300-400-500-800-1200. DRY300-400 - 1pc/dehumidifier, DRY500-800-1200 2pcs/dehumidifier	142
103009	Fan for DUCT DRY 500-800-1200	175
103012	Fan capacitor DUCT DRY 500-800-1200: 3.5µF 400/450V	10
103057	Fan switch PERIODICAL/CONTINUOUS	2

Humidistats

103022	Humidistat & Thermostat DIGITAL (FOX-2SHTR) BUILT-IN SILVER, METAL a DUCT	126
103020	Mechanical built-in humidistat /rotary/ ALL DEHUMIDIFIER MODELS	29
103021	Indication wheel for rotary humidistat / ALL DEHUMIDIFIER MODELS	2
103026	Mechanical external rotary humidistat EBERLE HYG-6001	80
103028	Mechanical external rotary humidistat EBERLE HYG-7001	85
RHT-RX	Receiver for wireless humidistat & thermostat DRY EASY 300	70
RHT-TX-2	Transmitter for wireless humidistat & thermostat DRY EASY 300	215
RHT-ANT	Antenna for wireless humidistat & thermostat DRY EASY 300	60

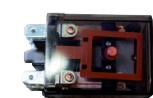

8. SPARE PARTS

8.A.

DEHUMIDIFIER SPARE PARTS

Price EXW
w/o VAT /EUR/

Valves and relays

103004	LP valve - DRY 300/400	19
103010	LP valve - DRY 500/800/1200	19
103059	Time relay JEL-111 - ALL DEHUMIDIFIER MODELS	35
103058	Power relay SCHRACK - DRY 300/400/500/800/1200	18
103069	Power relay OMRON DRY 800/1200	15
108001	Filling valve d6/100mm, SAE 1/4" ALL DEHUMIDIFIER MODELS	3
103019	Antifreeze thermostat +15°C	35



Capillaries

108006	Capillary DRY300, length: 1m	3.50
108016	Capillary TEEX 2.0, DRY400	3.50
108006	Capillary DRY500, length: 2.6 m	8.50
112001	Capillary DRY800	3.00
112002	Capillary DRY1200	4.00



Refrigerant filters and air filters

108015	Refrigerant Filter DRY300	3.50
108020	Refrigerant Filter DRY400/500	3.50
108022	Refrigerant Filter DRY800/1200	13.50
F1	Air Filter DRY300/400 TTW, G3	5.00
F2	Air Filter DRY500 TTW, G3	5.00
F3	Air Filter DRY800/1200 TTW, G3	5.00
F4	Air Filter DRY300/400 DUCT, G3	6.00
F5	Air Filter DRY500 DUCT, G3	7.00
F6	Air Filter DRY800/1200 DUCT, G3	9.00



General discount does not apply on above stated prices.
Stated prices are final.

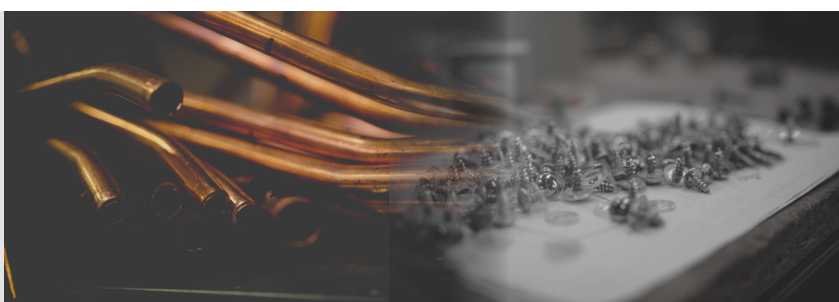

8. SPARE PARTS

8.B.

HEAT PUMP SPARE PARTS

Price EXW
w/o VAT /EUR/

Flow switch

203005	Flow switch HP1000-1100-1400-1500-1700-2300-2400-2800-3000	35
---------------	--	-----------



Exchangers

204003	Exchanger Inventor HP2300	425
---------------	---------------------------	------------

204004	Exchanger Inventor HP2800	525
---------------	---------------------------	------------



Controllers

HP18010	Controller - complete set HP1000, 2000, 30000, SW-SRO193032, SRO193033	199
----------------	--	------------

203022	Controller - Transformer	20
---------------	--------------------------	-----------

203008	Controller - Wall installation box	3
---------------	------------------------------------	----------

Wi-Fi box

203051	WIFI box SRO193034, 2x 1m connection cable, female and male connector	30
---------------	---	-----------



Temperature sensors

203011	Temperature sensor T1, T2, T5 (water, evaporator) (k5Ω)	3
---------------	---	----------

203013	Temperature sensor T3 (air, plastic) (k5Ω)	3
---------------	--	----------

203012	Temperature sensor T4 (compressor)(k50Ω)	3
---------------	--	----------



8. SPARE PARTS

8.B.

HEAT PUMP SPARE PARTS

Price EXW
w/o VAT /EUR/

Fan blades

209045	Fan blade HP 1000-1100-1400-1500	50
209035	Fan blade HP 2300-2400-2800-3000	50



Compressors

209083	Compressor HP1000-1100, GMCC Rotary	550
209084	Compressor HP1400-1500, GMCC Rotary	660
209090	Compressor HP2300-2400, Panasonic Scroll	790
209089	Compressor HP2800-3000, Panasonic Scroll	890



Others

209024	4-way valve electrical coil + copper valve HP1000-1100-1400-1500	30
209034	4-way valve electrical coil + copper valve HP2300-2400-2800-3000	30
HP18020	Set of silentblocks (4pcs)	18
HP18021	Condensate drain "L" part 90°	3
209029	Fan Motor C048 HP2300-2800-2400-3000	150
209031	Phase monitor HP2000-3000	60

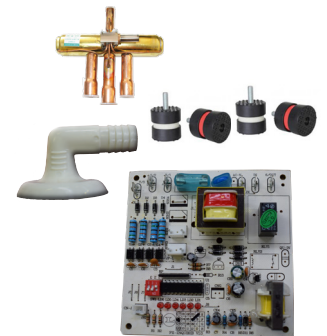

General discount does not apply on above stated prices.
Stated prices are final.

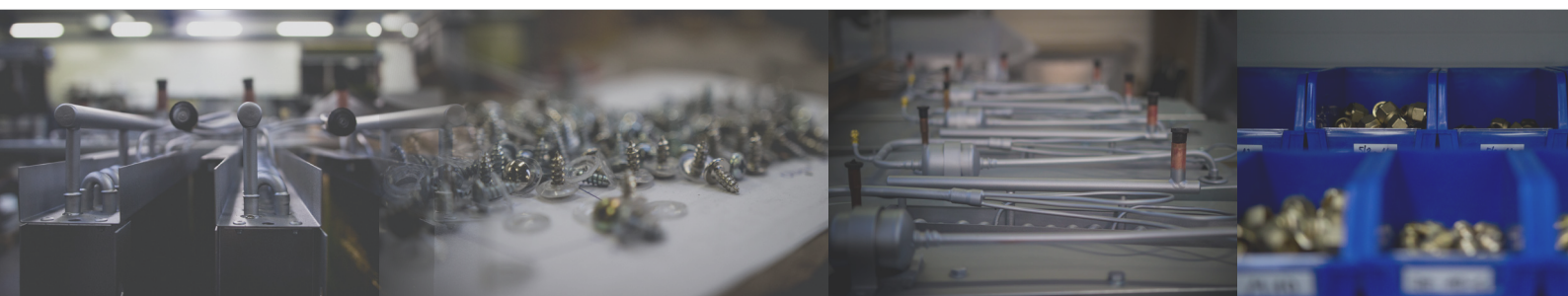

8. SPARE PARTS

8.C. HEAT PUMP SPARE PARTS for models HP GREEN

Price EXW
w/o VAT /EUR/

for model HP 1100 GREEN Inverter

209100	PC board (Heat&Cool) for HP1100 GREEN Inverter	155
209102	Round Touch controller (Heating&Cooling, with Wi-Fi) for HP1100 GREEN Inverter	130
209104	Inverter board (Heat&Cool) for HP1100 GREEN Inverter	220
209106	Water flow switch for HP1100 GREEN Inverter	35
209108	Fan motor for HP1100 GREEN Inverter	115
209110	High pressure protection switch for HP1100 GREEN Inverter	15
209112	Low pressure protection switch for HP1100 GREEN Inverter	15
209114	Water union for HP1100 GREEN Inverter	20
209116	Water union gasket for HP1100 GREEN Inverter	5

for model HP 1500 GREEN Inverter

209101	PC board (Heat&Cool) for HP1500 GREEN Inverter	155
209103	Round Touch controller (Heating&Cooling, with Wi-Fi) for HP1500 GREEN Inverter	130
209105	Inverter board (Heat&Cool) for HP1500 GREEN Inverter	220
209107	Water flow switch for HP1500 GREEN Inverter	35
209109	Fan motor for HP1500 GREEN Inverter	115
209111	High pressure protection switch for HP1500 GREEN Inverter	15
209113	Low pressure protection switch for HP1500 GREEN Inverter	15
209115	Water union for HP1500 GREEN Inverter	20
209117	Water union gasket for HP1500 GREEN Inverter	5

for model HP 1000 GREEN On-Off

209118	PC board (Heat&Cool) for HP1000 GREEN	145
209120	LCD controller (Heat&Cool) for HP1000 GREEN	85
209122	Water flow switch for HP1000 GREEN	35
209124	Fan motor for HP1000 GREEN	65
209126	Full set of sensors for HP1000 GREEN	8
209128	High & low pressure switch for HP1000 GREEN	15
209130	Water union 500mm black for HP1000 GREEN	20
209132	Water union gasket for HP1000 GREEN	5
209134	Drainage kit for HP1000 GREEN	8
209136	Fan for HP1000 GREEN	28

for model HP 1400 GREEN On-Off

209119	PC board (Heat&Cool) for HP1400 GREEN	145
209121	LCD controller (Heat&Cool) for HP1400 GREEN	85
209123	Water flow switch for HP1400 GREEN	35
209125	Fan motor for HP1400 GREEN	65
209127	Full set of sensors for HP1400 GREEN	8
209129	High & low pressure switch for HP1400 GREEN	15
209131	Water union 500mm black for HP1400 GREEN	20
209133	Water union gasket for HP1400 GREEN	5
209135	Drainage kit for HP1400 GREEN	8
209137	Fan for HP1400 GREEN	28



9. WATER SURFACE COVER

A swimming pool cover reduces the actual evaporation by 30-50%. This means that you need a smaller dehumidifier for a given pool, you will save on energy bill since smaller unit consumes less electricity and also you will reduce heat losses of your water, thus you will need smaller heating device (heat pump) and also it will consume less energy compared to pool without cover.

Blue bubble plastic cover is a perfect solution for a domestic or hotel pool.

Price change reserved



9.1 POOL COVER ROLLER

Price EXW

w/o VAT /EUR/

9.1.1. Pool cover roller - FIXED POSITION

9.1.1.A with telescopic tube length 2.7 - 4.4m **188**

9.1.1.B with telescopic tube length 3.7m - 5.4m **208**

9.1.1.C with telescopic tube length 4.1m - 5.7m **185**

9.1.1.D with telescopic tube length 5.3m - 6.9m **210**

9.1.2. Pool cover roller - MOBILE

9.1.2.A with telescopic tube length 2.7 - 4.4m **200**

9.1.2.B with telescopic tube length 3.7m - 5.4m **218**

9.1.3. Pool cover roller - SIDEWISE MOBILE

9.1.3.A with telescopic tube length 2.7 - 4.4m **250**

9.1.3.B with telescopic tube length 3.7 - 5.4m **275**

9.1.4. Pool cover roller - STANDING

9.1.4.A with telescopic tube length 2.7 - 4.4m **190**

9.1.4.B with telescopic tube length 3.7m - 5.4m **205**

9.1.5. Pool cover roller - FIXED ON THE WALL

9.1.5.A with telescopic tube length 2.6 - 4.3m **280**



9.2 BLUE BUBBLE PLASTIC SHEET

Price EXW

w/o VAT /EUR/

400 micr., 50m reel up, Light blue Geo Bubble material **/m/**

9.2.A width 3m **16.50**

9.2.B width 3.5m **19.50**

9.2.C width 4m **22.50**

9.2.D width 5m **27.50**

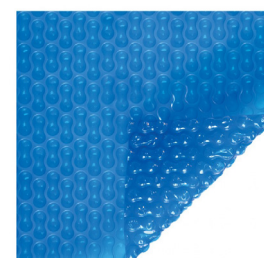

General discount does not apply on above stated prices. Stated prices are final.



10. VENTILATION

up to
300 m³/h

FREE
heated

Fan scheme

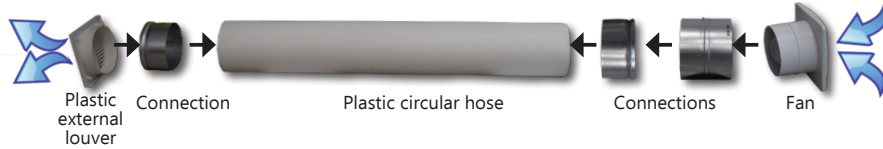

Price EXW
w/o VAT /EUR/

10.1. EXHAUST ventilation set

10.1.A Ventilation set A: Air flow: 100m³/h, Ø 100mm

Includes:

- Small axial extract fan DECOR 100
- Backdraft shutters RSK 100 ED
- Plastic external louvre LG100
- Plastic circular hose UK-PP 100/1000

120

10.1.B Ventilation set B: Air flow: 300m³/h, Ø 160mm

Includes:

- Small axial extract fan DECOR 300 SZ IPX4
- Backdraft shutters RSK 150 ED
- Plastic external louvre LG 150
- Plastic circular hose UK-PP 150/1000

150



Price EXW
w/o VAT /EUR/

10.2. FRESH AIR ventilation set

10.2.A FRESH AIR ventilation set A: with Fixed plastic external louvre

- Air flow: 100-300m³/h, Ø 100mm
- white color - RAL 9010
- Includes: Plastic circular hose LG100, Plastic circular hose UK-PP 100/1000

40

10.2.B FRESH AIR ventilation set B: with Electric plastic back draft louvre shutter

- Air flow: 100-300m³/h, Ø 100mm
- grey color - RAL 7035
- Includes: External electric louvre PAR 160 RAL7035, Plastic circular hose UK-PP 100/1000

400

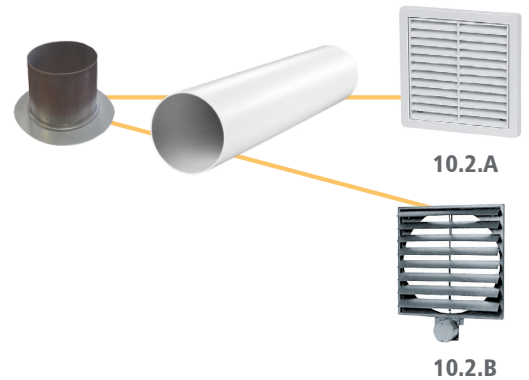

Installation scheme

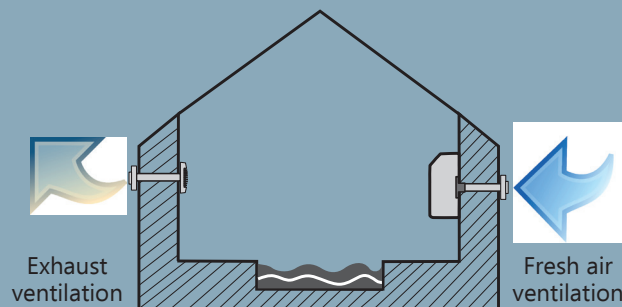

Bring fresh air into
your pool
and warm it with
the dehumidifier.



Our Innovation: **FRESH AIR SUPPLY**



Each Microwell dehumidifier has fresh air supply possibility. The air inlet is located under the condenser, that way the incoming fresh air is effectively heated at no cost thanks to heat recovery.



ADDITIONAL VENTILATION

Saving energy,
time & money

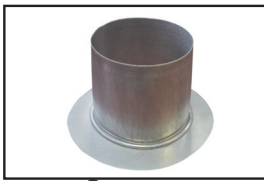

Fresh air metal extension for connection to dehumidifier

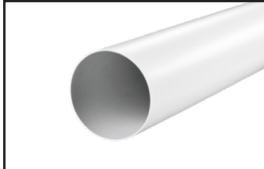

Plastic circular hose

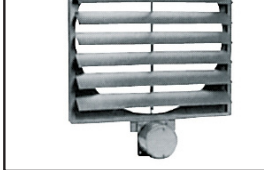

Plastic external louver

Compatibility to All DRY range.

MICROWELL, spol. s r.o.

SNP 2018/42, 927 01 Šal'a, SLOVAKIA

p (+421) 31/770 7082

m (+421) 911/413 990

e export@microwell.sk



www.microwell.eu



Branch office PRAHA

Hlavní 1195

251 68 Hlubočinka - Sulice, CZ

m (+420) 773 621 599

m (+420) 608 855 364

e praha@microwell.cz

www.microwell.cz

Branch office BRNO

Pražáková 66

639 00 Brno, CZ

p (+420) 549 257 241

m (+420) 608 855 364

e brno@microwell.cz

www.microwell.cz

Branch office OSTRAVA

Slévárenská 411/12

709 00 Ostrava, CZ

p (+420) 596 638 227

m (+420) 608 855 364

e ostrava@microwell.cz

www.microwell.cz

Branch office BUDAPEST

Attila út 4.

1013 Budapest, HU

m (+36) 30 875 58 51

e microwell@microwell.hu

www.microwell.hu

Manufacturer reserves the right to change the technical and visual parameters without notice.

